

SGH-C160

Quick Start Guide



SGH-C160

- Camera and camcorder
- Music player
- Photo printing
- Bluetooth
- SOS message
- Offline mode



Contents

Features	02
precautions	02
Phone Layout	03
Set & Link	04
Basic Use	04
Unpack	05
Solving Problem	06

Features

CAMERA AND CAMCORDER

- Use the camera module on your phone to take a photo or record a video.

MUSIC PLAYER

- Play music files using your phone as a music player. You can use other phone functions while listening to music.

FM RADIO

- Listen to your favourite radio stations anytime, anywhere.

IMAGE EDITOR

- Edit or decorate your photos.

PHOTO PRINTING

- Print your photos to preserve your best moments forever.

PHONE TO TV

- View photos and video clips captured with the phone on your TV screen.

OFFLINE MODE

- Switch your phone to Offline mode to use its non-wireless functions while on an airplane.

BLUETOOTH

- Transfer media files and personal data, and connect to other devices using wireless Bluetooth technology.

SOS MESSAGE

- Send SOS messages to your family or friends for help in an emergency.

Precautions

READ THESE GUIDELINES BEFORE USING YOUR WIRELESS PHONE. FAILURE TO COMPLY WITH THEM MAY BE DANGEROUS OR ILLEGAL.

DRIVE SAFELY AT ALL TIMES

- Do not use a hand-held phone while driving. Park your vehicle first.

SWITCH OFF WHEN REFUELLING

- Do not use the phone at a refuelling point (service station) or near fuels or chemicals.

SWITCH OFF IN AN AIRCRAFT

- Wireless phones can cause interference. Using them in an aircraft is both illegal and dangerous.

SWITCH OFF THE PHONE NEAR ALL MEDICAL EQUIPMENT

- Hospitals and health care facilities may be using equipment that could be sensitive to external RF energy. Follow any regulations or rules in force.

INTERFERENCE

- All wireless phones may be subject to interference, which could affect their performance.

Precautions

SPECIAL REGULATIONS

- Follow any special regulations in force in any area and always switch off your phone whenever it is forbidden to use it.

WATER RESISTANCE

- Your phone is not water-resistant. Keep it dry.

SENSIBLE USE

- Use only in the normal position (held to your ear). Avoid unnecessary contact with the antenna when the phone is switched on.

EMERGENCY CALLS

- Key in the emergency number for your present location, then press . Do not end the call until given permission to do so.

SMALL CHILDREN AND YOUR PHONE

- Keep the phone and all its parts including accessories out of reach of small children.

ACCESSORIES AND BATTERIES

- Use only Samsung-approved batteries and accessories, such as headsets and PC data cables. Use of any unauthorised accessories could damage your phone and may be dangerous.

QUALIFIED SERVICE

- Only qualified service personnel may repair your phone.

Phone Layout

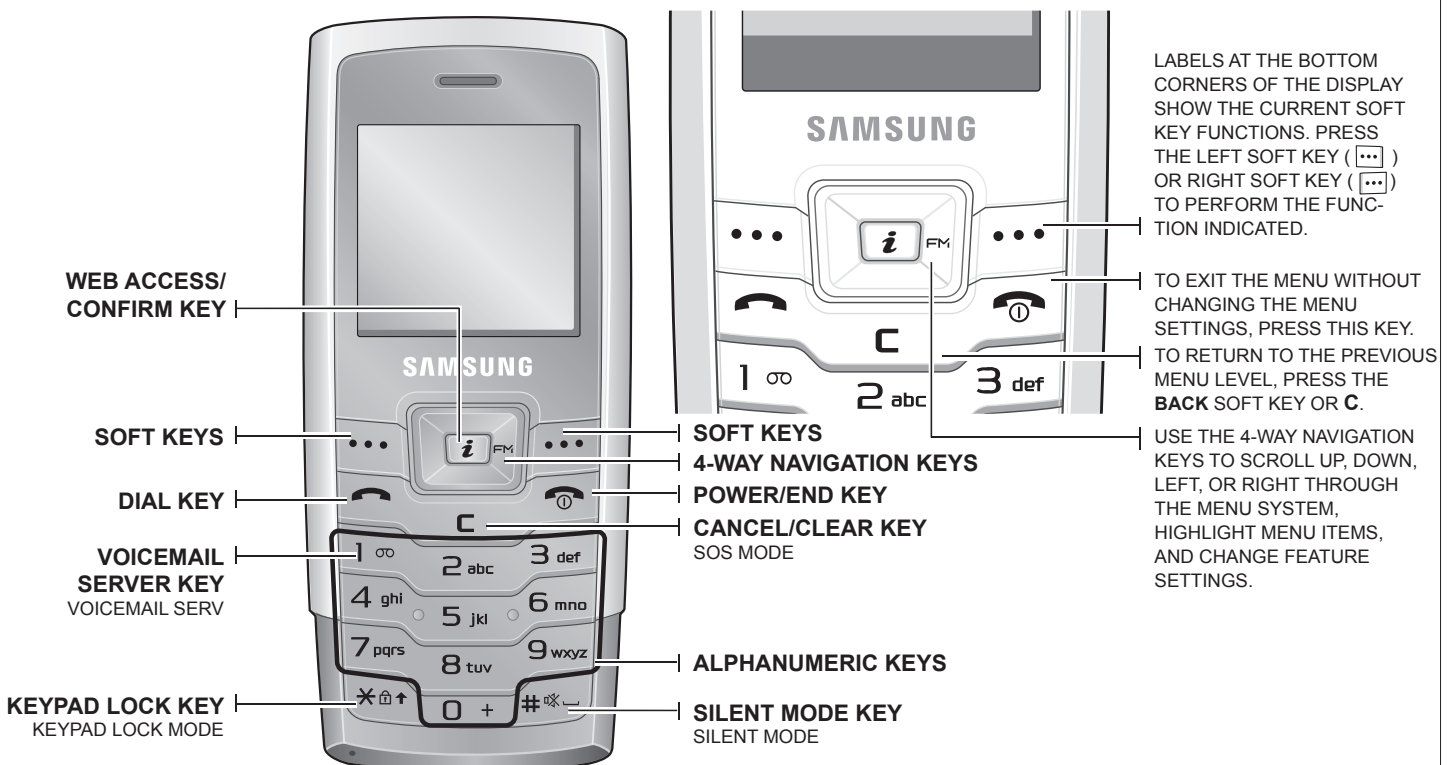

Set & Link

First steps to operating your phone

INSERT THE SIM CARD.

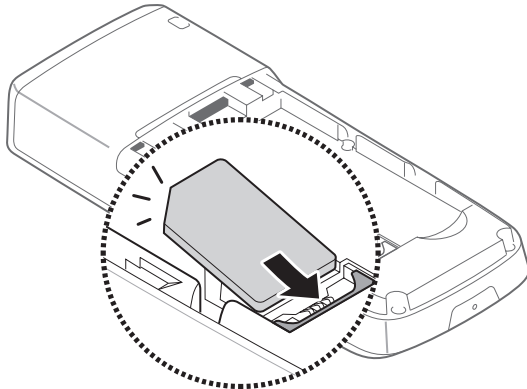

Make sure that the goldcoloured contacts on the card face down into the phone.

INSERT THE BATTERY.

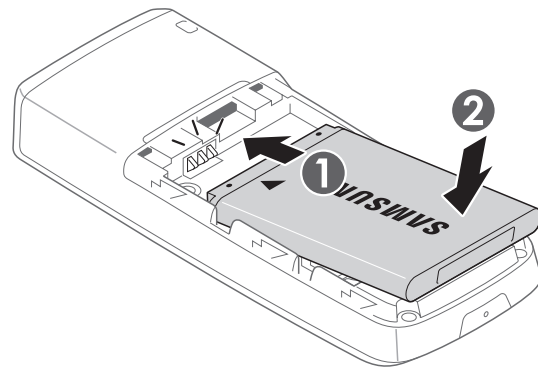

REPLACE THE BATTERY COVER.

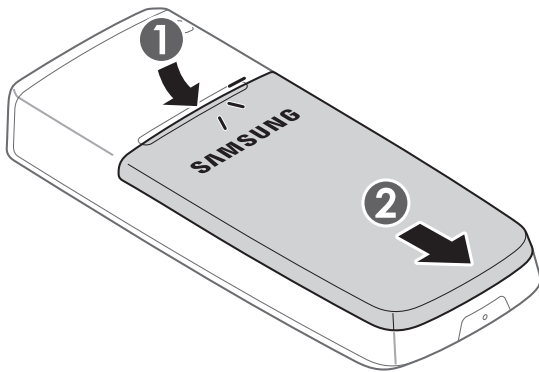

PLUG THE TRAVEL ADAPTER INTO THE PHONE.

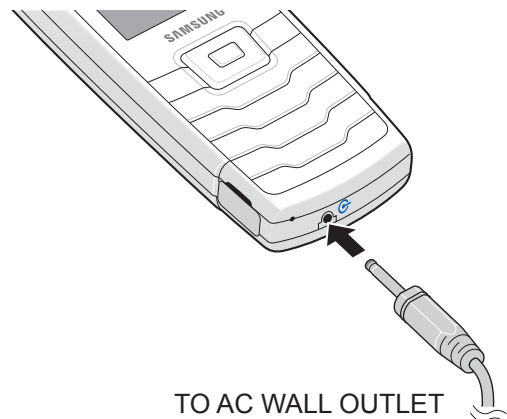

Basic Use

Make or answer calls

MAKING A CALL

1. In Idle mode, enter an area code and phone number, and press .
2. When you want to end the call, press .

ANSWERING A CALL

1. When the phone rings, press the Accept soft key or to answer a call.

To reject the call, press the Reject soft key or .

2. To end the call, press .

T9 mode

1. Press **2** to **9** to start entering a word. Press each key once for one letter.

Example: To enter "Hello" in T9 mode, press **4**, **3**, **5**, **5**, and **6**.

T9 predicts the word that you are typing, and it may change with each key that you press.

2. Enter the whole word before editing or deleting characters.
3. When the word displays correctly, go to step 4. Otherwise, press **0** to display alternative word choices for the keys that you have pressed.
For example, "Of" and "Me" use **6** and **3**.
4. Press to insert a space and enter the next word.

ABC mode

Press the keys labelled with the character you want:

- once for the first character
- twice for the second character
- and so on.

For example, press **2** three times to enter "**C**" and **5** two times to enter "**K**."

UNPACK

Make sure you have each item

- Phone
- Travel adapter
- Battery
- User's Guide

You can obtain various accessories from your local Samsung dealer.

Note: • The items supplied with your phone and the accessories available at your Samsung dealer may vary, depending on your country or service provider.

Solving Problem

When you switch your phone on, the following messages may appear

“INSERT SIM”

- Make sure that the SIM card is correctly installed

“PHONE LOCK”

- The automatic locking function has been enabled.
You must enter the phone's password before you can use the phone.

ENTER PUK

- The PIN code was entered incorrectly three times in succession and the phone is now blocked.
Enter the PUK supplied by your service provider.

ENTER PIN

- You are using your phone for the first time.
You must enter the Personal Identification Number (PIN) supplied with the SIM card.
- The PIN Check feature is enabled. Every time the phone is switched on, the PIN has to be entered. To disable this feature, use the PIN check menu.

“NO SERVICE,” “NETWORK FAILURE,” OR “NOT DONE” DISPLAYS

- The network connection has been lost. You may be in a weak signal area. Move and try again.
- You are trying to access an option for which you have not taken out a subscription with your service provider. Contact the service provider for further details.

YOU HAVE ENTERED A NUMBER BUT IT WAS NOT DIALLED

- Make sure that you have pressed SEND
- Make sure that you have accessed the right cellular network.
- Make sure that you have not set an outgoing call barring option.

Solving Problem

A CALLER CANNOT REACH YOU

- Make sure that your phone is switched on. (Press END for more than one second.)
- Make sure that you are accessing the correct cellular network.
- Make sure that you have not set an incoming call barring option.

YOUR VOICE IS NOT HEARD AT THE OTHER END

- Make sure that you have switched on the microphone.
- Make sure that you are holding the phone close enough to your mouth.
The microphone is located at the bottom of the phone.

THE PHONE STARTS BEEPING AND “BATTERY LOW” FLASHES ON THE DISPLAY

- Your battery is insufficiently charged. Recharge the battery.

THE AUDIO QUALITY OF THE CALL IS POOR”

- Check the signal strength indicator on the display (📶).
The number of bars indicates the signal strength from strong (📶) to weak (📶).
- Try moving the phone slightly or moving closer to a window if you are in a building.

NO NUMBER IS DIALLED WHEN YOU RE-CALL A ADDRESS ENTRY

- Use the Phonebook feature to ensure the number has been stored correctly.
- Store the number again, if necessary.

THE BATTERY DOESN'T CHARGE PROPERLY OR THE PHONE SOMETIMES TURNS ITSELF OFF

- Wipe the charging contacts both on the phone and on the battery with a clean soft cloth.

IF THE ABOVE GUIDELINES DO NOT HELP YOU TO SOLVE THE PROBLEM, TAKE NOTE OF

- The model and serial numbers of your phone
- Your warranty details
- A clear description of the problem