



## NOTICE

Copyright © Vertu 2003. All rights reserved.

Reproduction, transfer, distribution or storage of part or all of the contents in this document in any form without the prior written permission of Vertu is prohibited.

Vertu is a registered trademark of Vertu Limited. Vertu product names are either trademarks or registered trademarks of Vertu Limited. Other product and company names mentioned herein may be trademarks or tradenames of their respective owners.

US Patent Pending No. 29/178,730 and other pending patents. T9 text input software copyright © 1997-2003. Tegic Communications, Inc. All rights reserved.

Includes RSA BSAFE cryptographic or security protocol software from RSA Security.

Vertu operates a policy of continuous and on-going development. Vertu reserves the right to make changes and improvements to any of the products described in this document without prior notice.

UNDER NO CIRCUMSTANCES SHALL VERTU BE RESPONSIBLE FOR ANY LOSS OF DATA OR INCOME OR ANY SPECIAL, INCIDENTAL, CONSEQUENTIAL OR INDIRECT DAMAGES HOWSOEVER CAUSED.

THE CONTENTS OF THIS DOCUMENT ARE PROVIDED "AS IS". EXCEPT AS REQUIRED BY APPLICABLE LAW, NO WARRANTIES OF ANY KIND, EITHER EXPRESSED OR IMPLIED, INCLUDING, BUT NOT LIMITED TO, THE IMPLIED WARRANTIES OF MERCHANTABILITY AND FITNESS FOR A PARTICULAR PURPOSE, ARE MADE IN RELATION TO THE ACCURACY, RELIABILITY OR CONTENTS OF THIS DOCUMENT. VERTU RESERVES THE RIGHT TO REVISE THIS DOCUMENT OR WITHDRAW IT AT ANY TIME WITHOUT PRIOR NOTICE.

The availability of particular products may vary by region. Please contact Vertu Concierge for more information.

## EXPORT CONTROLS

Your Vertu phone may contain commodities, technology, or software exported from the United States in accordance with the Export Administration regulations. Diversion contrary to U.S. law is prohibited.

## FCC/INDUSTRY CANADA NOTICE

Your Vertu phone may cause TV or radio interference (for example, when using a telephone in close proximity to receiving equipment). The FCC or Industry Canada can require you to stop using your phone if such interference cannot be eliminated. If you require assistance, contact Vertu Concierge. This device complies with part 15 of the FCC rules. Operation is subject to the condition that this device does not cause harmful interference.

## DECLARATION OF CONFORMITY

We, Vertu Ltd. declare under our sole responsibility that the product, **Vertu Ascent** is in conformity with the provision of the following Council Directive: 1999/5/EC.

**CE168**

## WELCOME

Communication is a fine art. Creating a work of art begins with a vision.

Our vision is to transform personal mobile communications into an unparalleled experience in every sense.

Vertu has been created for people who share our passions - our love of the exceptional, our delight in beauty and excellence, our unrelenting pursuit of the near unattainable.

See it. Touch it. Hear it. Use it. The Vertu vision of luxury communications is waiting to be discovered.

## ABOUT THIS MANUAL

### GLOSSARY OF TERMS

The following terms are used in this guide:

**NUMBER KEYS** The keys that are used to enter (key in) text or numbers.

**DEFAULT** Initial product setting as supplied by Vertu when it leaves our manufacturing facility.

**SIM CARD** Subscriber Identity Module. This is a small card supplied by your service provider to insert into your Vertu phone for a network connection.

**SERVICE PROVIDER** The provider of your SIM card and all associated network services.

**NETWORK SERVICE** A feature which is made available at the discretion of your service provider.

**STAND-BY DISPLAY** The display that appears when your Vertu phone is switched on, with **menu** and **directory** at the bottom.

## CONVENTIONS

The following conventions are used in this guide:

**menu** Represents text that appears on your Vertu phone's display, for example, "From the stand-by display, press **menu**."

**SEND** Represents a Vertu phone key, for example, "Press the **SEND** key to make the call."



**Caution. Important information relating to health and safety.**



*Represents a tip. Useful information or a quick way to access or operate a feature.*



*Represents a note. Points to be aware of when using your Vertu phone.*

## IMPORTANT INFORMATION

The wireless phone described in this guide is approved for use on EGSM 900 and GSM 1900 networks. Contact your service provider for more information about networks.

When using your Vertu phone, obey all laws and respect the privacy and legitimate rights of others.



**Warning. All of your Vertu phone's features, other than the alarm clock, require the phone to be switched on to use the features. Do not switch your Vertu phone on when wireless phone use may cause interference or danger.**

## NETWORK SERVICES

To use the phone you must have service from a wireless service provider. Many of the features in your Vertu phone depend on features in the wireless network to function. These network services may not be available on all networks or you may have to make specific arrangements with your service provider before you can utilise network services. Your service provider may need to give you additional instructions for their use and explain what charges will apply. Some networks may have limitations that affect how you can use network services. For instance, some networks may not support all language-dependent characters and services.

Your service provider may also have requested that certain features be disabled or not activated in your Vertu phone. If so, they will not appear on your menus. Contact your service provider for more information.

## SHARED MEMORY

Some of the data features in your Vertu phone share memory. Using one or more of these features may reduce the memory available for the remaining features sharing memory. For example, saving many hundreds of phone book entries may use all of the available memory. Your phone may display a message that the memory is full when you try to use a shared memory feature. In this case, delete some of the information or entries stored in the shared memory features before continuing. Some of the features, such as the directory, have a certain amount of memory specially allotted to them in addition to the amount of memory shared with other features.

## SAFETY POINTS



**Caution. Do not switch on the phone when wireless phone use is prohibited or when it may cause interference or danger. Please read these simple guidelines. Disregarding these rules may be dangerous or illegal.**

Your phone has an internal antenna. As with any other radio transmitting device, do not touch the antenna unnecessarily when the phone is switched on.

Contact with the antenna affects call quality and may cause the phone to operate at a higher power level than otherwise needed. Avoiding contact with the antenna during a call optimises the antenna performance and the talk time of your Vertu phone.

Your Vertu phone and its accessories may contain small parts. Keep them out of reach of small children.

|                             |  |   |
|-----------------------------|--|---|
| ROAD SAFETY COMES FIRST     |  | <i>Obey all local laws. Always keep your hands free to operate the vehicle while driving. Your first consideration while driving should be road safety.</i>   |
| INTERFERENCE                |  | <i>All wireless phones may be susceptible to interference which could affect performance.</i>   |
| SWITCH OFF IN HOSPITALS     |  | <i>Follow any regulations or rules. Switch phone off near medical equipment.</i>  |
| SWITCH OFF IN AIRCRAFT      |  | <i>Follow any regulations or rules. Wireless devices can cause interference in aircraft.</i>  |
| SWITCH OFF WHEN REFUELLING  |  | <i>Do not use the phone at a refuelling point. Do not use near fuel or chemicals.</i>   |
| SWITCH OFF NEAR BLASTING    |  | <i>Do not use the phone where blasting is in progress. Observe restrictions and follow any regulations.</i>   |
| USE SENSIBLY                |  | <i>Use only in normal position (shown on page 1-6) and do not touch the antenna unnecessarily.</i>  |
| QUALIFIED SERVICE           |  | <i>Only qualified service personnel must install or repair phone equipment.</i>   |
| ACCESSORIES AND BATTERIES   |  | <i>Use only approved accessories and batteries. Do not connect incompatible products.</i>   |
| WATER RESISTANCE            |  | <i>Your Vertu phone is not water-resistant. Keep it dry.</i>  |
| BACK-UP COPIES              |  | <i>Remember to make back-up copies or keep a written record of any important information stored in your phone.</i>  |
| CONNECTING TO OTHER DEVICES |  | <i>When connecting to any other device, read its user guide for detailed safety instructions. Do not connect incompatible devices.</i>  |
| EMERGENCY CALLS             |  | <i>Ensure your Vertu phone is switched on and in service. Press the END key as many times as needed to clear the display and return to the main screen. Enter the emergency number, then press the SEND key. Give your location. Do not end the call until told to do so.</i> |

## TABLE OF CONTENTS

**01 GETTING STARTED**

- 1-1 > VERTU PHONE LAYOUT
- 1-2 > THE BATTERY AND SIM CARD
- 1-3 > VERTU PHONE KEYPAD
- 1-4 > SWITCHING ON YOUR VERTU PHONE
- 1-4 > ENTERING YOUR PIN CODE
- 1-4 > SETTING THE TIME AND DATE
- 1-5 > DISPLAY ICONS AND INDICATORS
- 1-6 > MAKING CALLS
- 1-6 > YOUR FIRST CALL
- 1-6 > ANSWERING CALLS
- 1-6 > ADJUSTING VOLUME
- 1-6 > ENDING OR REJECTING CALLS
- 1-6 > LAST NUMBER REDIAL
- 1-7 > CALLING YOUR VOICE MAILBOX
- 1-7 > EMERGENCY CALLS
- 1-7 > MAKING AN EMERGENCY CALL
- 1-8 > KEYPAD LOCK
- 1-8 > LOCKING THE KEYPAD
- 1-8 > RECEIVING A CALL
- 1-8 > UNLOCKING THE KEYPAD
- 1-9 > VERTU CONCIERGE
- 1-9 > CALLING VERTU CONCIERGE

**02 THE DIRECTORY**

- 2-1 > MEMORY TYPES
- 2-1 > PHONE MEMORY
- 2-1 > SIM CARD MEMORY
- 2-1 > SELECTING THE MEMORY TYPE
- 2-2 > SETTING UP YOUR DIRECTORY
- 2-2 > ADDING DIRECTORY ENTRIES
- 2-2 > ACCESSING DIRECTORY ENTRIES
- 2-3 > MULTIPLE ITEMS IN A DIRECTORY ENTRY
- 2-5 > SETTING THE DIRECTORY VIEW
- 2-5 > USING YOUR DIRECTORY
- 2-5 > SEARCHING AND CALLING
- 2-6 > SENDING TEXT MESSAGES
- 2-7 > BUSINESS CARDS
- 2-8 > ASSIGNING NUMBERS TO THE SPEED DIAL LIST
- 2-8 > ORGANISING YOUR DIRECTORY
- 2-8 > COPYING BETWEEN MEMORIES
- 2-10 > CHECK MEMORY STATUS
- 2-10 > CALLER GROUPS
- 2-12 > EDITING YOUR DIRECTORY

**03 THE MENUS**

- 3-2 > USING THE MENUS
- 3-2 > ACCESSING MENUS BY SCROLLING
- 3-3 > MESSAGES
- 3-3 > WRITING AND SENDING TEXT MESSAGES
- 3-9 > READING TEXT MESSAGES
- 3-12 > TEXT MESSAGE FOLDERS
- 3-15 > MESSAGE SETTINGS
- 3-17 > CALL REGISTER
- 3-19 > ADDITIONAL CALL REGISTER OPTIONS
- 3-20 > PROFILES
- 3-20 > PROFILE ICONS
- 3-20 > ACTIVATING A PROFILE
- 3-20 > PERSONALISING A PROFILE
- 3-22 > RENAMING A PROFILE
- 3-23 > SETTINGS
- 3-23 > ALARM CLOCK
- 3-24 > CLOCK
- 3-25 > CALL SETTINGS
- 3-26 > PHONE SETTINGS
- 3-28 > COMMUNICATION SETTINGS
- 3-29 > SECURITY SETTINGS
- 3-29 > RESTORE DEFAULT SETTINGS
- 3-30 > CALL DIVERT
- 3-31 > AGENDA
- 3-31 > SETTING UP YOUR AGENDA
- 3-33 > AGENDA OPTIONS
- 3-33 > CREATING AGENDA NOTES
- 3-37 > AGENDA NOTE OPTIONS
- 3-40 > SIM SERVICES

**04 ADVANCED CALL FUNCTIONS**

- 4-1 > SPEED DIALLING
- 4-1 > ACTIVATING SPEED DIALLING
- 4-1 > ASSIGNING SPEED DIAL NUMBERS
- 4-2 > VIEWING THE SPEED DIAL LIST
- 4-2 > CALLING WITH SPEED DIALLING
- 4-2 > SPEED DIAL OPTIONS
- 4-3 > SPEAKER PHONE
- 4-3 > CALL WAITING
- 4-3 > ACTIVATING CALL WAITING
- 4-4 > USING CALL WAITING
- 4-4 > SWAPPING BETWEEN CALLS
- 4-4 > ENDING ONE OF THE CALLS
- 4-4 > ENDING BOTH CALLS

- 4-5 > IN CALL FUNCTIONS
- 4-5 > CALL HOLDING
- 4-5 > MUTING A CALL
- 4-6 > MAKING MULTIPLE CALLS
- 4-6 > SWAPPING BETWEEN CALLS
- 4-6 > ENDING ONE OF THE CALLS
- 4-6 > ENDING BOTH CALLS
- 4-6 > TRANSFERRING CALLS
- 4-7 > CONFERENCE CALLS
- 4-8 > PAUSE AND WAIT COMMANDS
- 4-8 > SETTING UP PAUSE AND WAIT COMMANDS
- 4-9 > USING PAUSE AND WAIT COMMANDS

## 05 ACCESSORIES

- 5-1 > HEADSET
- 5-2 > CHARGER
- 5-2 > CHARGING YOUR BATTERY
- 5-3 > DATA CABLE
- 5-4 > INSTALLING VERTU DATA SUITE
- 5-4 > BATTERY
- 5-6 > BATTERY INFORMATION
- 5-6 > CHARGING AND DISCHARGING
- 5-6 > BATTERY CARE AND SAFETY

## 06 SECURITY INFORMATION

- 6-1 > SECURITY FEATURES
- 6-3 > SECURITY CODE
- 6-3 > CHANGING THE SECURITY CODE
- 6-4 > SECURITY LEVEL
- 6-4 > CHANGING THE SECURITY LEVEL
- 6-4 > PIN CODE
- 6-5 > ACTIVATING THE PIN CODE
- 6-5 > CHANGING THE PIN CODE
- 6-6 > CALL BARRING SERVICE
- 6-6 > SETTING UP THE CALL BARRING SERVICE
- 6-7 > FIXED DIALLING
- 6-7 > SETTING UP FIXED DIALLING
- 6-7 > CLOSED USER GROUP
- 6-7 > SETTING UP A CLOSED USER GROUP

## 07 SHORTCUTS, ICONS AND SCREEN SAVER

- 7-1 > SHORT-CUTS
- 7-2 > DISPLAY ICONS
- 7-2 > BATTERY AND SIGNAL ICONS
- 7-2 > STATUS ICONS
- 7-3 > CALL STATUS INDICATORS
- 7-3 > DIRECTORY ENTRY TYPE ICONS
- 7-3 > TEXT MESSAGE ICONS
- 7-4 > TEXT INPUT ICONS
- 7-4 > PROFILE ICONS
- 7-4 > AGENDA NOTE ICONS
- 7-4 > PROGRESS INDICATOR
- 7-5 > SCREEN SAVER
- 7-5 > THE SCREEN SAVER DISPLAY
- 7-6 > CHANGING THE SCREEN SAVER DELAY

## 08 ADDITIONAL INFORMATION

- 8-1 > SAFETY INFORMATION
- 8-1 > TRAFFIC SAFETY
- 8-1 > OPERATING ENVIRONMENT
- 8-1 > ELECTRONIC DEVICES
- 8-1 > PACEMAKERS
- 8-1 > HEARING AIDS
- 8-1 > OTHER MEDICAL DEVICES
- 8-1 > VEHICLES
- 8-2 > AIRCRAFT
- 8-2 > POSTED FACILITIES
- 8-2 > POTENTIALLY EXPLOSIVE ATMOSPHERES
- 8-2 > WATER RESISTANCE
- 8-2 > SPECIFICATIONS
- 8-2 > POWER MANAGEMENT
- 8-3 > CARE AND MAINTENANCE
- 8-3 > CERAMICS AND SAPPHIRE
- 8-3 > LEATHER
- 8-3 > METAL
- 8-3 > THE MICROFIBRE POLISHING CLOTH
- 8-3 > GENERAL CARE TIPS



## 0 | GETTING STARTED

### VERTU PHONE LAYOUT

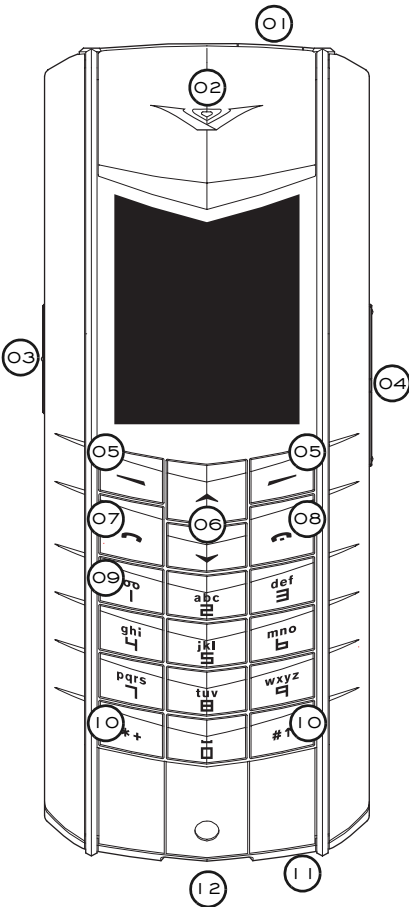

- > 01 POWER key – press and hold for a few seconds to switch on and switch off.
- > 02 Earpiece.
- > 03 CONCIERGE key – press and hold until **concierge** is displayed. Press SEND to call.
- > 04 VOLUME key – press the top of the key to increase the volume. Press the bottom of the key to decrease the volume.
- > 05 SELECTION keys – press to perform the action or access the feature shown on the display above the key.
- > 06 SCROLL keys – press to move, for example through a list of names or features.
- > 07 SEND key – press to make or answer a call.
- > 08 END key – press to end a call.
- > 09 VOICEMAIL key – press and hold to call your voice mailbox (a Network service).
- > 10 \*+ and #† keys – special function keys.
- > 11 Microphone.
- > 12 Accessories connector.

## THE BATTERY AND SIM CARD

If your Vertu phone was purchased at a Vertu store, the battery and SIM card should have been installed already. Otherwise, follow the procedure below to install your SIM card and battery.

The SIM card and its contacts are easily damaged. Be careful when handling, inserting or removing the card.



**Caution. Keep SIM cards and the back cover release key out of the reach of small children.**

**Always switch the phone off and disconnect the charger before removing the battery.**

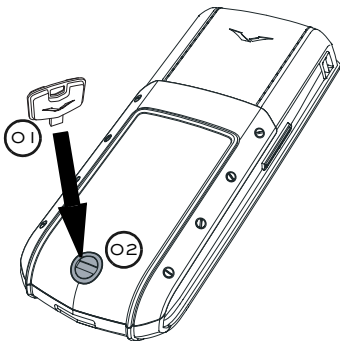

- > With the back of your Vertu phone facing you, position the back cover release key (01) very carefully into the slot of the locking screw (02). Ensure the key does not slip out of the slot.

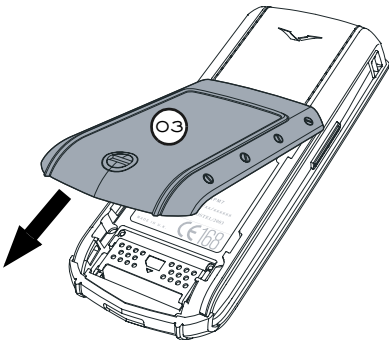

- > Turn the locking screw (02) a quarter of a turn anticlockwise, gently pivot (by no more than 45 degrees) and lift off the back cover (03) towards you as shown. If you accidentally remove the back cover while the phone is switched on, the phone will automatically switch off.



*Attach the back cover release key to your keyring for convenience.*

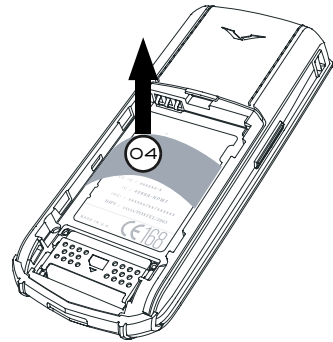

- > Remove the plastic placeholder (04) from your Vertu phone before inserting the battery.



*Retain the plastic placeholder for future use. If you need to remove the battery, insert the plastic placeholder before replacing the back cover to make it easier to remove the back cover*

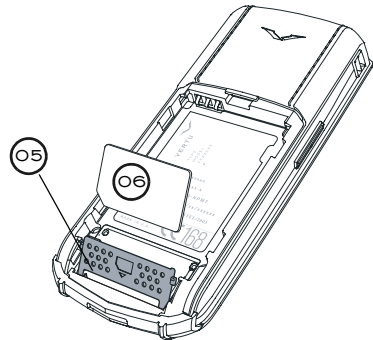

- > Slide the SIM retainer (05) towards the bottom of your Vertu phone and then pivot outwards.
- > Insert the SIM card into the retainer, ensuring that the bevelled corner (06) is located bottom left and the gold contact area is facing towards the gold contact points inside the phone.
- > Return the retainer to its original position and slide it towards the top of the phone. The retainer should firmly lock into place.



*For availability and information on using SIM card services, contact your SIM card vendor. This may be the service provider, network operator, or other vendor.*

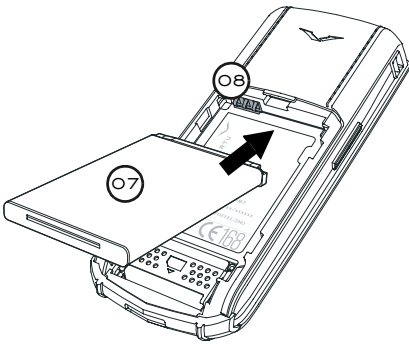

- > Insert the battery (07) top end first. Ensure that the contacts on the top end of the battery align with the contact points (08) inside the battery compartment.

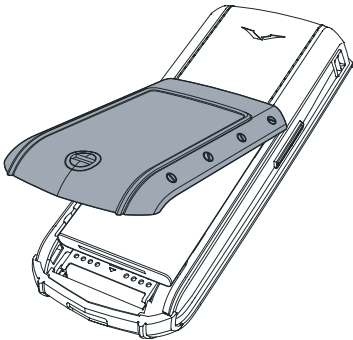

- > Ensure that the battery and SIM card are seated correctly before replacing the back cover.
- > Pivot and slide the back cover into position until it clicks into place. The cover should close tightly using only light pressure – do not force it closed! If the cover does not close easily, remove it and check the battery and SIM are correctly inserted, and the retainer (09) is correctly positioned and locked.

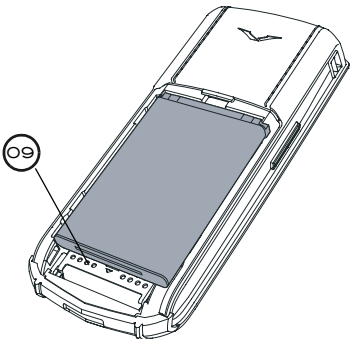

For information about removing the battery, refer to “Removing the battery” on page 5-4.

## VERTU PHONE KEYPAD

Alphanumeric keys, referred to as NUMBER keys in this guide, are used to key in numbers or characters, for example when making calls, storing names in the directory or writing text messages.

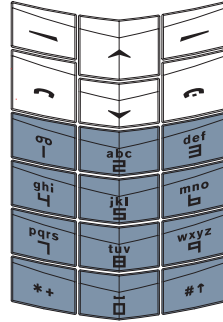

Below the display are two SELECTION keys. The function of these keys depends on the text displayed above them.

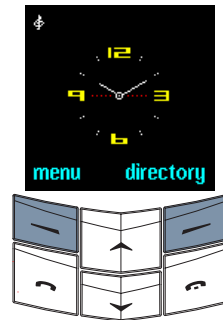

For example, press the SELECTION key below **menu** to access the menu or press the SELECTION key below **directory** to access the directory.

When pressing keys, press them briefly and firmly, without holding them down unless otherwise instructed.

## SWITCHING ON YOUR VERTU PHONE

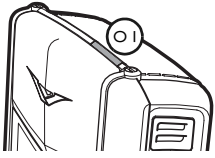

- > Press and hold the **POWER** key (01) for a few seconds until the display activates to switch on your Vertu phone.

If your battery requires charging, a **battery low** message is displayed when you first switch on your Vertu phone. Refer to for more information.

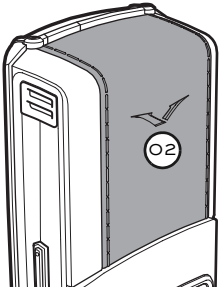

- > Your Vertu phone has an internal antenna located inside the top-rear panel (02). Do not touch the antenna unnecessarily when phone is switched on.

Contact with the antenna affects call quality and may cause the phone to operate at a higher power level than otherwise needed. Avoiding contact with the antenna area when operating the phone optimises the antenna performance and battery life.

## ENTERING YOUR PIN CODE

Depending on your SIM card settings, you may be prompted to enter a PIN (Personal Identification Number) code when you switch on your Vertu phone. This code is used to protect access to your SIM card and is independent of your Vertu phone. If you used your SIM card in another phone previously, the code will be the same.

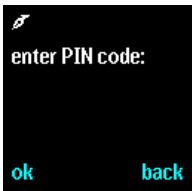

- > Use the **NUMBER** keys to key in your PIN code.
- > Press **ok**.

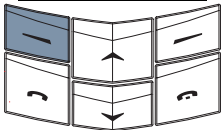

 *It is recommended that you activate both the PIN code and security code to help prevent unauthorised use of your SIM card and your Vertu phone. Refer to the "Security" chapter for more information.*

## SETTING THE TIME AND DATE

If the time and date are not set, you are prompted to enter your time settings when you first switch on your Vertu phone.

If your Vertu phone was purchased at a Vertu store, the time and date should already be set for you.



*We recommend setting the time and date immediately to ensure that features which use the time and date, for example the agenda, operate correctly.*

To set the time and when you switch on your Vertu phone for the first time:

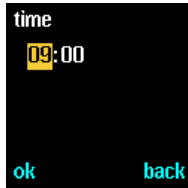

- > Use the **NUMBER** keys to key in the correct time.
- > Use the **SCROLL** keys to toggle between hours and minutes.

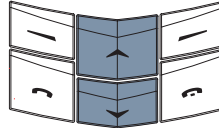

You can enter the time in either 12-hour (AM/PM) format or 24-hour format.

For example, to set the time to 08:30:

- > Key in "8".
- > Scroll to minutes. The leading zero is added to the hour figure.
- > Key in "30".
- > Press **ok**.

Or, to set the time to 12:30:

- > Key in "12". The cursor automatically jumps to the minutes.
- > Key in "30".
- > Press **ok**.

If the hour you entered was not in 24-hour format, you are prompted to confirm if the time entered is AM or PM:

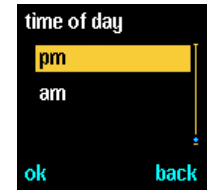

- > Scroll to **am** or **pm**.
- > Press **ok**. A confirmation message is displayed.

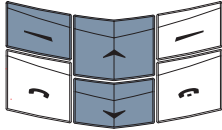

To set the date:



- > Use the **NUMBER** keys to key in the date.
- > Use the **SCROLL** keys to move between the figures.
- > Press **ok**. A confirmation message is displayed.

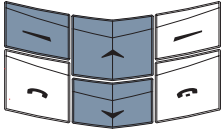

 *If the battery is removed from your Vertu phone for longer than two hours, you may need to set the time and date again.*

To change time and date settings refer to “Setting up your agenda” on page 3-31.

## DISPLAY ICONS AND INDICATORS

The display shows the current status of your Vertu phone.



The battery charge and signal strength indicators appear at the top of the display.



Indicates the signal strength of the network at your current location.



Indicates the battery charge level.



Indicates that both battery and signal levels are at full strength.







Indicates that both battery and signal levels are below full strength.



Indicates that the signal strength at your current location is too weak to make calls and that your battery is critically low.

Status icons are displayed below the battery charge and signal strength indicators. The most commonly displayed icons are:

-  Indicates that you have received one or more text messages.
-  Indicates that you have received one or more voice messages (a Network service).
-  Indicates that the **general** profile is selected. Alternative icons are displayed for the other profiles.
-  Indicates that audible alerts are disabled and no sounds are made when you receive calls or text messages.
-  Indicates that the keypad is locked.

For a complete list of icons, refer to “Display icons” on page 7-2.

## MAKING CALLS

### YOUR FIRST CALL



> Check the signal strength indicator. If the display indicates poor signal, adjust your physical location to be clear of obstructions that may block the signal.

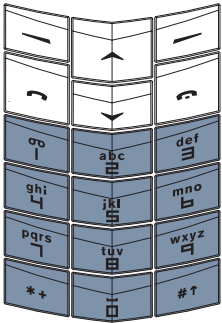

> From the stand-by display, use the NUMBER keys to key in the number you want to call.



When keying in international numbers, press the \* + key twice instead of keying in the international access code. A plus (+) sign appears on the display to represent the international access code.

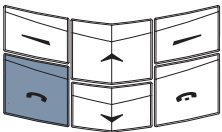

> Press the SEND key to begin your call. It may take several seconds to establish your call.



> Hold your Vertu phone in the normal speaking position during your conversation. Avoid unnecessary contact with the antenna as this may degrade call quality.

## ANSWERING CALLS

When you receive an incoming call, by default, a ringing tune is played and a call message is displayed. If enabled, your Vertu phone also vibrates.

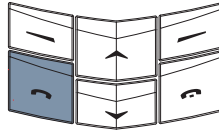

> Press the SEND key to answer an incoming call.



While in a call, you can use the speaker phone for a hands free call. Refer to "Speaker phone" on page 4-3 for more information.

## ADJUSTING VOLUME

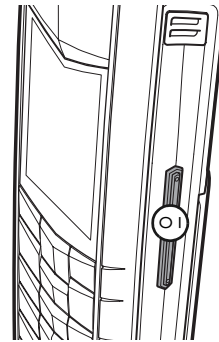

Use the VOLUME key (01) on the right side of your Vertu phone to obtain a comfortable listening level. The key has a rocker action.

> Press the top of the key to increase the volume.

> Press the bottom of the key to decrease the volume.

## ENDING OR REJECTING CALLS

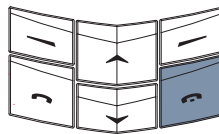

> Press the SEND key to end a call or reject an incoming call.

## LAST NUMBER REDIAL

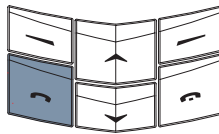

> From the stand-by display, press the SEND key to access a list of the most recently dialed numbers.

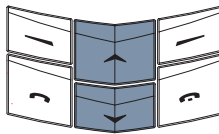

> Use the SCROLL keys to scroll to the desired number.

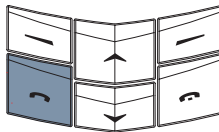

> Press the SEND key to call the selected number.

## CALLING YOUR VOICE MAILBOX

Voice mail is a network service for receiving voice messages that may be offered by your service provider.

To use the VOICEMAIL key to listen to your voice messages, the voice mailbox number must be stored in your Vertu phone.

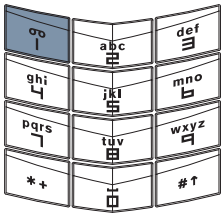

- > Press and hold the 1 key. This is the VOICEMAIL key.
- > If you are prompted, key in the voice mailbox number and press **ok**.

For more information on voicemail contact your service provider.

## EMERGENCY CALLS

**IMPORTANT!** Your Vertu phone, like any wireless phone, operates using radio signals, wireless and landline networks as well as user-programmed functions. Because of this, connections in all conditions cannot be guaranteed. Therefore, you should never rely solely upon any wireless phone for essential communications, for example medical emergencies.

Emergency calls may not be possible on all wireless phone networks or when certain network services and/or phone features are in use. Check with local service providers.

### MAKING AN EMERGENCY CALL

- > If the phone is not on, switch it on. Some networks may require that a valid SIM card is properly inserted in the phone.
- > Check for adequate signal strength and battery charge level.
- > Press the END key as many times as needed to return to the stand-by display.
- > Key in the emergency number for your present location, for example 112, 911 or other official emergency number. Emergency numbers vary by location.
- > Press the SEND key.

If certain features are in use, you may first need to turn those features off before you can make an emergency call. For more information consult the User Manual or your local service provider.

When making an emergency call, remember to give all the necessary information as accurately as possible.

Remember that your phone may be the only means of communication at the scene of an accident – do not cut off the call until given permission to do so.

## KEYPAD LOCK

You can lock the keypad on your Vertu phone to prevent the keys being operated accidentally, for example when it is in your pocket or bag.

### LOCKING THE KEYPAD

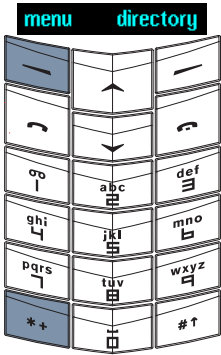

- > From the stand-by display, press **menu** followed by the \* + key within two seconds. A confirmation message is displayed.

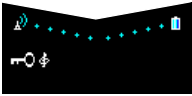

When the keypad is locked, a key icon appears below the signal strength indicator.



When the keypad is locked, calls may still be possible to the emergency number programmed into your Vertu phone, for example 112, 911 or other official emergency number.

- > Key in the emergency number.
- > Press SEND.

The emergency number is displayed only after you have keyed in its last digit

## RECEIVING A CALL

Your Vertu phone keypad lock is automatically suspended when you receive an incoming call.

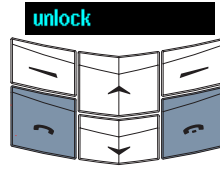

- > Press the SEND key to answer a call when the keypad is locked.
- > During the call your Vertu phone can be operated as normal.
- > Press the END key to end a call or reject an incoming call.

The keypad reverts to locked when you end the call.

### UNLOCKING THE KEYPAD

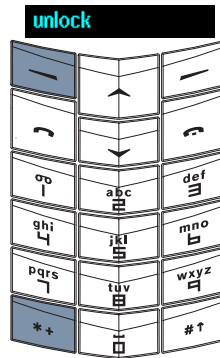

- > Press **unlock** followed by the \* + key within two seconds. A confirmation message is displayed.



## VERTU CONCIERGE

Vertu Concierge is an exclusive service for people who believe that quality matters. Our aim is to bring you only the very best, whether it be music, art, travel or food.

Vertu Concierge provides you with a highly personalised range of services:

- > *Lifestyle services, for example, restaurant recommendations and reservations, travel assistance, and tickets for theatre shows, concerts or sporting events.*
- > *Solving everyday practical problems such as finding a reputable plumber or tracking down a gift.*
- > *Assistance with using your Vertu phone.*

When you connect to Vertu Concierge, you can speak directly to a team of specialists, available 24 hours a day, 7 days a week, to offer personalised assistance.



*At present, calls to Vertu Concierge are answered in English, with limited capabilities in other languages. We will continue to expand our language coverage in the future, and clients will be notified of new languages as they become available.*

## CALLING VERTU CONCIERGE

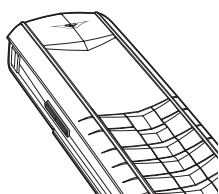

The **CONCIERGE** key is located on the left side of your Vertu phone as shown.



- > From the standby display, press and hold the **CONCIERGE** key for approximately two seconds, until **conciERGE** appears.

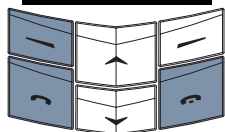

- > Press **call** or the **SEND** key to call Vertu Concierge.
- > Press the **END** key when you have finished the call.

## O2 THE DIRECTORY

The directory acts as a personal phone book with a potential capacity for up to 1,000 entries.

### MEMORY TYPES

Names and numbers can be stored in both the phone memory and the SIM card memory, but only one memory can be used at a time. The default setting of your Vertu phone is set to SIM card memory.

### PHONE MEMORY

The phone memory has greater storage capacity and the directory has more functionality when you use the phone memory.

When using the phone memory, directory entries are stored on your Vertu phone, and each directory entry can contain up to five numbers and two text items, such as a postal address or e-mail address.

### SIM CARD MEMORY

The SIM card memory has more flexibility than the phone memory because you can transfer a SIM card containing directory entries from your Vertu phone to another GSM mobile phone that supports small SIM cards.

When using the SIM card memory, directory entries are stored on your SIM card, and each directory entry contains one name and one associated number. The number of entries and the length of names and numbers that you can store on your SIM card is determined by your service provider.

## SELECTING THE MEMORY TYPE

Certain features, such as business cards and multiple items in a directory entry, are only available when using the phone memory. If you plan to make frequent use of these features, we recommend that you set your Vertu phone to use the phone memory. If you plan to transfer your SIM card from your Vertu phone to other phones, we recommend that you set your Vertu phone to use the SIM card memory.

To select a memory type:

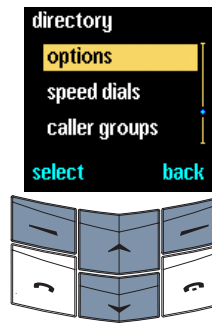

- > From the stand-by display, press **directory**.
- > Scroll to **options**.
- > Press **select**. **memory in use** appears.

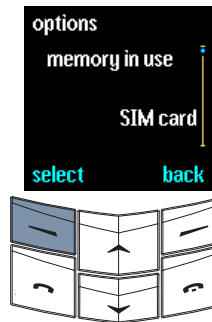

- > Press **select**.

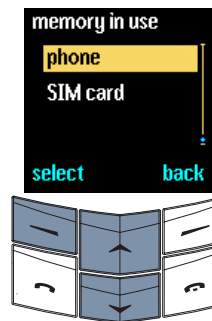

- > Scroll to **SIM card** or **phone**.
- > Press **select**. A confirmation message appears.

 If you change the SIM card in your Vertu phone, the memory type is automatically reset to **SIM card**.

## SETTING UP YOUR DIRECTORY

Your Vertu phone allows you to add multiple items to directory entries, and allows you to change how your directory displays the entries.

### ADDING DIRECTORY ENTRIES



- > From the stand-by display, press **directory**.
- > Scroll to **add entry**.
- > Press **select**.

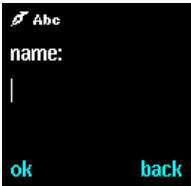
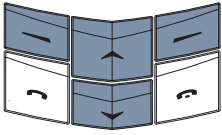

- > Key in the name.
- > Press **ok**.
- > Key in the number.
- > Press **ok**. A confirmation message appears.
- > Press **done**.

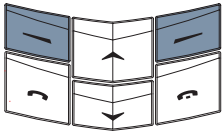

### ACCESSING DIRECTORY ENTRIES

There are several ways to access a directory entry, this gives you the flexibility to use your Vertu phone the way that suits you best.

To access a directory entry:

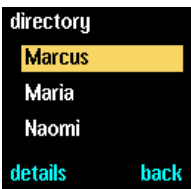

- either
- > From the stand-by display, press a **scroll** key.
  - > Key in the first letter of the desired name. The first name starting with that letter is highlighted.
  - > Scroll to the desired name.
  - > Press **details**.

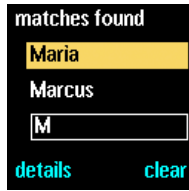
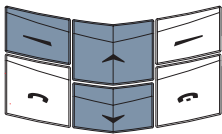

- or
- > From the stand-by display, press **directory**. **search** is highlighted.
  - > Press **select**.
  - > Key in the first character or characters of the desired name.
  - > Press **search**.
  - > Scroll to the desired name.
  - > Press **details**.

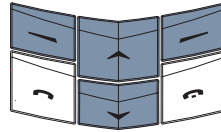

- or
- > From the stand-by display, press **directory**. **search** is highlighted.
  - > Press **select**.
  - > Press **list**.
  - > Scroll to the desired name.
  - > Press **details**.

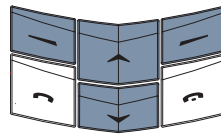





In this chapter we will use the first method of accessing a directory entry. You may choose to use any of the three methods described above.

## MULTIPLE ITEMS IN A DIRECTORY ENTRY

(Phone memory only)

The first number added to an entry in the directory is automatically set as the default number. When you select an entry from the directory to make a call or send a message to, this default number is always used.

You can store up to five numbers in each entry. Each number can be set as any of the following types, which are indicated by the icons shown:



-  **general**
-  **mobile**
-  **home**
-  **office**
-  **fax**

In addition, you can store up to two text items for each name. Each text item can be set as any of the following types:

-  **e-mail**
-  **postal address**
-  **note**

 *An entry can have duplicate number and text types, for example two mobile numbers.*

The example below shows a fully populated directory entry, with five numbers and two text items, for the name Maria:

-  **general**  
+44 1250 1234
-  **mobile**  
+44 1700 3421
-  **home**  
+44 1250 2000
-  **office**  
+44 1580 4201
-  **fax**  
+44 1580 3000
-  **e-mail**  
maria@vertu.com
-  **note**  
not working Fridays

## ADDING ADDITIONAL NUMBERS TO AN ENTRY

To add more than one number to a directory entry:

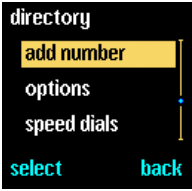

- > From the stand-by display, press **directory**.
- > Scroll to **add number**.
- > Press **select**.
- > Scroll to the desired name.
- > Press **add no..**



- > Scroll to the type of number you require.
- > Press **select**.

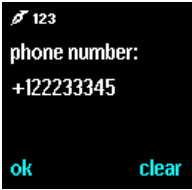

- > Key in the number.
- > Press **ok**. A confirmation message appears.
- > Press **done**.

## ADDING TEXT TO AN ENTRY

To add a text item to a directory entry:

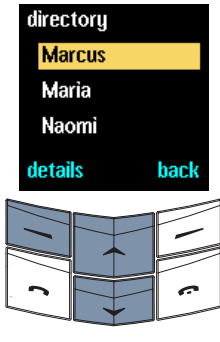

directory  
**Marcus**  
 Maria  
 Naomi  
 details back

- > From the stand-by display, press a **SCROLL** key.
- > Key in the first letter of the desired name. The first name starting with that letter is highlighted.
- > Scroll to the desired name.
- > Press **details**.

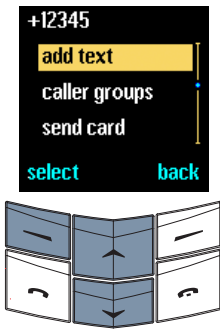

+12345  
**add text**  
 caller groups  
 send card  
 select back

- > Press **options**.
- > Scroll to **add text**.
- > Press **select**.

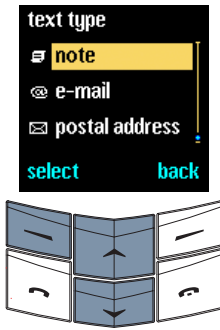

text type  
**note**  
 e-mail  
 postal address  
 select back

- > Scroll to the text type you require.
- > Press **select**.

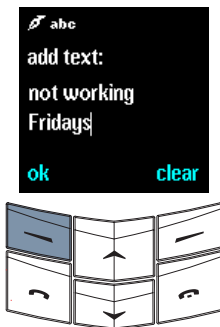

abc  
 add text:  
 not working  
 Fridays  
 ok clear

- > Key in the text.
- > Press **ok**. A confirmation message appears.

Repeat the steps in this section to add another text item to the directory entry.

## CHANGING THE DEFAULT NUMBER

The first number added to a name in the directory is automatically set as the default number. If more than one number is added to an entry, for example if the person has a mobile phone number and an office number, you can change the default number.

To change the default number:

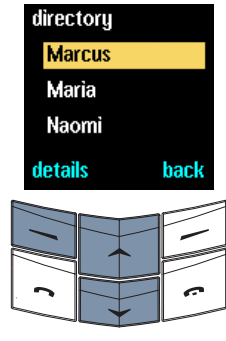

directory  
**Marcus**  
 Maria  
 Naomi  
 details back

- > From the stand-by display, press a **SCROLL** key.
- > Key in the first letter of the desired name. The first name starting with that letter is highlighted.
- > Scroll to the desired name.
- > Press **details**.

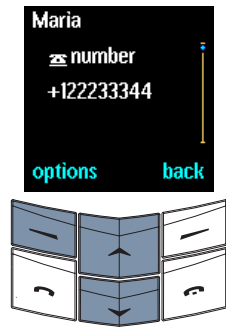

Maria  
number  
 +122233344  
 options back

- > Scroll to the required number.
- > Press **options**.

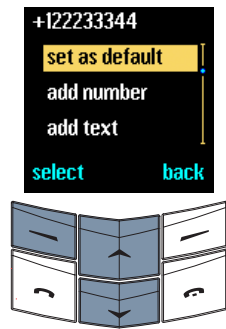

+122233344  
**set as default**  
 add number  
 add text  
 select back

- > Scroll to **set as default**.
- > Press **select**. A confirmation message appears.

 The default number is indicated by an underline beneath the icon for the number type.

## SETTING THE DIRECTORY VIEW

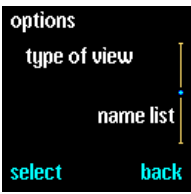

Your Vertu phone can display the entries in your directory in two ways. **name list** displays three names at a time, **name & number** displays one name at a time along with its default number.

To set the type of view:

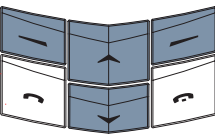

options  
type of view  
name list  
select back

- > From the stand-by display, press **directory**.
- > Scroll to **options**.
- > Press **select**.
- > Scroll to **type of view**.
- > Press **select**.

type of view  
name list  
name & number  
select back

- > Scroll to the desired type of view.
- > Press **select**. A confirmation message appears.

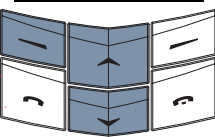

## USING YOUR DIRECTORY

Using your directory you can make a call, send a text message and send a business card to someone whose contact information is saved in a directory entry. You can also assign numbers to the speed dial list.

### SEARCHING AND CALLING

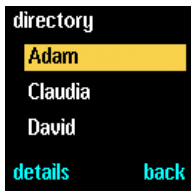

The following section assumes your Vertu phone's directory is set to **name list**. If you have set your directory to **name & number**, your display will not appear exactly as shown, but the steps you take are the same.

To search for an entry and call the default number:

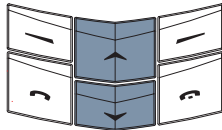

directory  
Adam  
Claudia  
David  
details back

- > From the stand-by display, press a **SCROLL** key.
- > Key in the first letter of the desired name, for example "M". The first name starting with that letter is highlighted.

directory  
Marcus  
Maria  
Naomi  
details back

- > Scroll to the desired name.



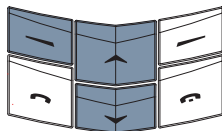

☑ Maria  
options speaker

- > Press the **SEND** key to call the number.



To search for an entry and call a number other than the default number (phone memory only):



- > From the stand-by display, press a **SCROLL** key.
- > Key in the first letter of the desired name. The first name starting with that letter is highlighted.

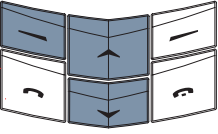

- > Scroll to the desired name.
- > Press **details**.

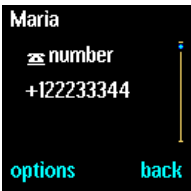

- > Scroll to the required number.
- > Press the **SEND** key to make the call.

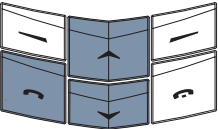

## SENDING TEXT MESSAGES

You can send a text message to someone using the options in the directory menu.

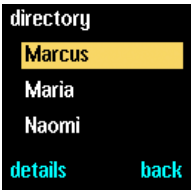

- > From the stand-by display, press a **SCROLL** key.
- > Key in the first letter of the desired name. The first name starting with that letter is highlighted.

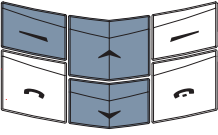

- > Scroll to the desired name.
- > Press **details**.
- > Scroll to the required number.
- > Press **options**.



- > Scroll to **send message**.
- > Press **select**.
- > Key in the message.
- > Press **options**. **send** is highlighted.

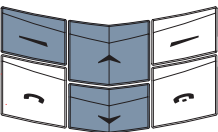

- > Press **select**. A confirmation message appears.

For more information on sending text messages, see "Writing and sending text messages" on page 3-3.

## BUSINESS CARDS

The business card function allows you to send and receive a person's contact information as a text message. This function can be used with both the phone memory and the SIM card memory.

### SENDING BUSINESS CARDS

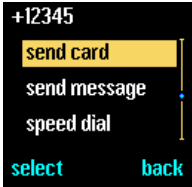

- > From the stand-by display, press a **SCROLL** key.
- > Scroll to the name of the person whose details you want to send.

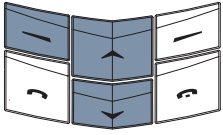

- > Press **details**.
- > Press **options**.
- > Scroll to **send card**.
- > Press **select**. If the entry has more than one item **send default no.** appears.



- > Scroll to **send default no.** or **send all details**.
  - > Press **select**.
- Either
- > Key in the number.

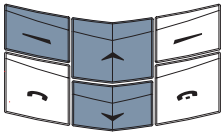

- > Press **ok**. A confirmation message appears.

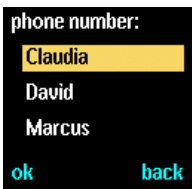

- or
- > Press **search** to access the list of names in your directory.
  - > Scroll to the name of the person you want to receive the business card.

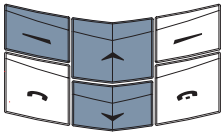

- > Press **ok**.
- > Press **ok** to confirm. A confirmation message appears.



*The phone memory can store additional contact information such as a person's work and mobile phone numbers and an e-mail address. All this contact information can be sent using the **send all details** option. If you are using SIM card memory, you do not have this option.*

### RECEIVING BUSINESS CARDS

When you receive a business card, an information message appears on the display. An audible alert sounds if your Vertu phone is set up for audible alerts.



- > Press **view**.
- > Press **options**. **save** is highlighted.

To save the business card to your directory:

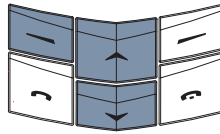

- > Press **select**. A confirmation message appears.

To discard the business card without saving it:

- > Scroll to **erase**.
- > Press **select**.
- > Press **ok** to confirm. A confirmation message appears.



## ASSIGNING NUMBERS TO THE SPEED DIAL LIST

The directory allows you to program your speed dial list easily using the **speed dial** option in the **options** submenu.

To add a number to the speed dial list:

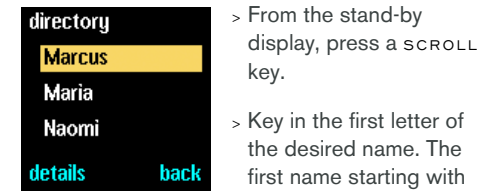

> From the stand-by display, press a **SCROLL** key.

> Key in the first letter of the desired name. The first name starting with that letter is highlighted.

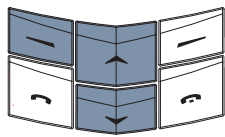

> Scroll to the desired name.

> Press **details**.

> Scroll to the required number.

> Press **options**.



> Scroll to **speed dial**.

> Press **select**.

> Scroll to the desired speed dial key.

> Press **select**. A confirmation message appears.

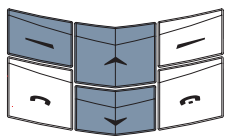

For more information on speed dials see "Speed dialling" on page 4-1.

## ORGANISING YOUR DIRECTORY

Your Vertu phone allows you to organise your directory by copying directory entries between memory types and by grouping directory entries into caller groups.

### COPYING BETWEEN MEMORIES

The copying feature allows you to copy names and numbers between the phone memory and the SIM card memory.

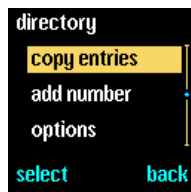

> From the stand-by display, press **directory**.

> Scroll to **copy entries**.

> Press **select. from phone to SIM card** appears.

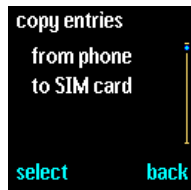
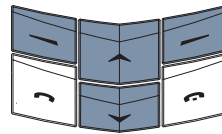

Either

> Press **select**.

or

> Scroll to **from SIM card to phone**.

> Press **select**.

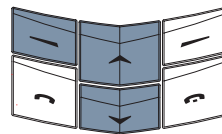

### COPYING OPTIONS

The following options are available and are accessed as follows:

#### one by one

Copy your directory entries one at a time by selecting each entry to copy.

**one by one** is highlighted after you access the submenu.

> Press **select**.

> Scroll to the required name.

> Press **copy. keep original** is highlighted.

- Either
- > Press **select**. A confirmation message appears.
- or
- > Scroll to **erase original**.
- > Press **select**. A confirmation message appears.

Repeat these steps to copy another entry.

**all**

- Copy all your directory entries at once.
- > Scroll to **all**.
  - > Press **select**. **keep original** is highlighted.

- Either
- > Press **select**.
  - > Press **ok** to start copying.
- or
- > Scroll to **erase original**.
  - > Press **select**.
  - > Press **ok** to start copying. A confirmation message appears.

**default numbers**  
(Phone memory only)

- Copy only the default numbers from your phone memory to your SIM card memory. Other numbers in the directory that are not set as the default are not copied.
- > Scroll to **default numbers**.
  - > Press **select**. **keep original** is highlighted.

- Either
- > Press **select**. A confirmation message appears.
  - > Press **ok** to start moving.
- or
- > Scroll to **erase original**.
  - > Press **select**. A confirmation message appears.
  - > Press **ok** to start moving. A confirmation message appears.



*If you are copying from phone memory to SIM card memory and your phone memory contains more entries than your SIM card can store, some of the entries will not be copied.*

**COPYING INDIVIDUAL ENTRIES**

You can also copy individual directory entries between the phone memory and SIM card memory directly from the list of names in your directory.

To copy individual entries:



- > From the stand-by display, press a **scroll** key.
- > Key in the first letter of the desired name. The first name starting with that letter is highlighted.
- > Scroll to the desired name.
- > Press **details**.

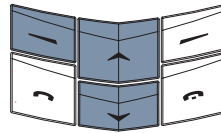

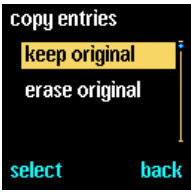

- > Press **options**.
- > Scroll to **copy entry**.
- > Press **select**. **keep original** is highlighted.

- Either
- > Press **select**. A confirmation message appears.
- or
- > Scroll to **erase original**.
  - > Press **select**. A confirmation message appears.

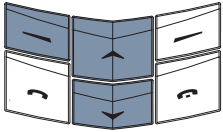

#### CHECK MEMORY STATUS

You can check the status of your phone memory and SIM card memory to see how much information is stored and how much free capacity is available in each.

To check the status of the phone and SIM card memories:

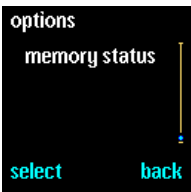

- > From the stand-by display, press **directory**.
- > Scroll to **options**.
- > Press **select**.
- > Scroll to **memory status**.

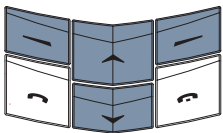

- > Press **select**. The SIM card memory status is displayed.
- > Press a **SCROLL** key to display the phone memory status.

 *The SIM card memory capacity is defined by your SIM card, not by your Vertu phone. For more information contact your service provider.*

#### CALLER GROUPS

Use caller groups to allocate names in your directory to different groups. The group name appears on the display when a member of a group calls you. You can change the names of your caller groups to be more specific, and you can assign a different ringing tune to each group for easy recognition of incoming calls. The default group names are:

- > **family**
- > **VIP**
- > **friends**
- > **colleagues**
- > **other**

#### ADDING A NAME TO AN EMPTY GROUP

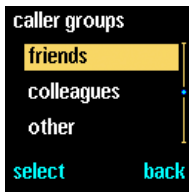

- > From the stand-by display, press **directory**.
- > Scroll to **caller groups**.
- > Press **select**.

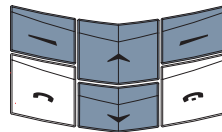

- > Scroll to the desired group.
- > Press **select**.

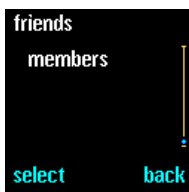

- > Scroll to **members**.
- > Press **select**. **add entry** is highlighted.

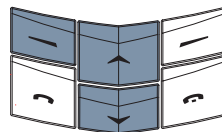



- > Press **ok**. The list of names in your directory appears.
- > Scroll to the required name.
- > Press **add**. A confirmation message appears.

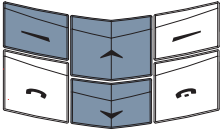

#### ADDING ADDITIONAL NAMES TO THE GROUP



- > Press **options**.
- > Scroll to **add entry**.
- > Press **ok**.

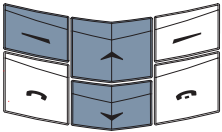

- > Scroll to the required name.
- > Press **add**. A confirmation message appears.
- > Repeat the last five steps to continue adding names to the group.

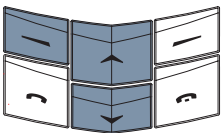

#### ADDING INDIVIDUAL ENTRIES TO A GROUP

You can also add individual entries to a caller group directly from the list of names in your directory.

To add individual entries:

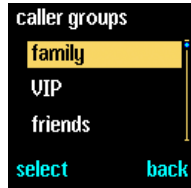

- > From the stand-by display, press a **scroll** key.
- > Scroll to the desired name.
- > Press **details**.
- > Press **options**.
- > Scroll to **caller groups**.
- > Press **select**.
- > Scroll to the desired caller group.
- > Press **select**. A confirmation message appears.

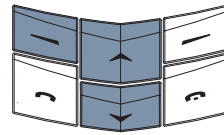

#### REMOVING A NAME FROM A GROUP

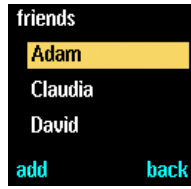

- > From the stand-by display, press **directory**.
- > Scroll to **caller groups**.
- > Press **select**.
- > Scroll to the desired group.
- > Press **select**.
- > Scroll to **members**.
- > Press **select**.
- > Scroll to the entry you want to remove from the group.
- > Press **options**. **remove entry** is highlighted.
- > Press **ok**. A confirmation message appears.

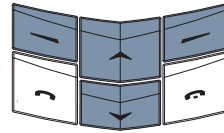

## RENAMING A GROUP

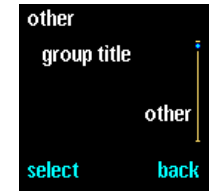

- > From the stand-by display, press **directory**.
- > Scroll to **caller groups**.
- > Press **select**.
- > Scroll to the required group.
- > Press **select**. **group title** appears.
- > Press **select**.
- > Edit the group title as required.
- > Press **ok**. A confirmation message appears.

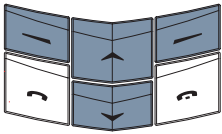

## SETTING GROUP RINGING TUNES

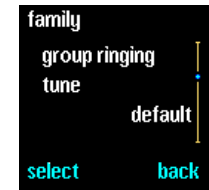

- > From the stand-by display, press **directory**.
- > Scroll to **caller groups**.
- > Press **select**.
- > Scroll to the desired group.
- > Press **select**.
- > Scroll to **group ringing tune**.
- > Press **select**.

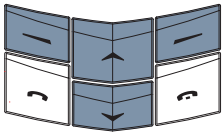

- > Scroll to the desired tune.
- > Press **ok**. A confirmation message appears.

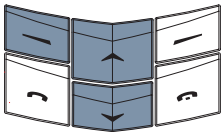

 The default ringing tune in the **group ringing tune** submenu is the tune you set your Vertu phone to in the **profiles** menu.

## EDITING YOUR DIRECTORY

The directory provides you with several editing options to help you manage your directory entries.

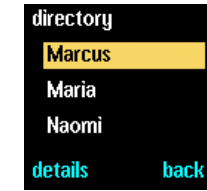

- > From the stand-by display, press a **scroll** key.
- > Key in the first letter of the desired name. The first name starting with that letter is highlighted.
- > Scroll to the desired name.
- > Press **details**.
- > Scroll to the number or text item you want to edit.
- > Press **options**.

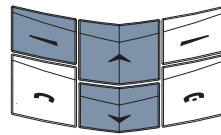

Several editing options are available and are accessed as follows:

### edit number

Edit the number for the entry you selected.

**edit number** is highlighted after you access the options submenu.

- > Press **select**.
- > Use the **scroll** keys to move the cursor through the number.
- > Press **clear** as many times as needed to delete the number before the cursor.
- > Key in the new number.
- > Press **ok** when you have finished editing. A confirmation message appears.

- erase number** Erase the number from the entry.
- > Scroll to **erase number**.
  - > Press **select**.
  - > Press **ok**. A confirmation message appears.
- change type**  
(Phone memory only) Change the number to a different type, for example, change **general** to **home**.
- > Scroll to **change type**.
  - > Press **select**.
  - > Scroll to the required type.
  - > Press **select**. A confirmation message appears.
- edit name** Edit the name of the person you selected.
- > Scroll to **edit name**.
  - > Press **select**.
  - > Use the **scroll** keys to move the cursor through the name.
  - > Press **clear** as many times as needed to delete the character before the cursor.
  - > Key in the characters.
  - > Press **ok** when you have finished editing. A confirmation message appears.
- erase entry** Erase a complete directory entry, including the person's name and associated contact details from your directory.
- > Scroll to **erase entry**.
  - > Press **select**.
  - > Press **ok**. A confirmation message appears.

## 03 THE MENUS

Your Vertu phone offers an extensive range of functions that are organised in a series of submenus as listed below.



*Some of the features or functions on your Vertu phone are only available at the discretion of your service provider. For more information contact your service provider.*



write message  
inbox  
outbox  
archive  
templates  
personal folders  
erase messages  
message settings  
message centre number  
messages sent as  
message validity  
default recipient number  
delivery reports  
reply to you via same centre  
message profiles



missed calls  
received calls  
dialled numbers  
erase call lists  
call duration  
last call duration  
all calls duration  
received calls duration  
dialled calls duration  
clear timers  
call costs  
last call units  
all calls units

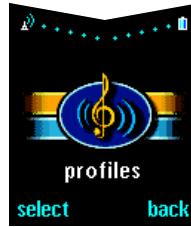

general  
silent  
soft  
loud  
pager  
headset\*  
profiles submenus:  
activate  
personalise  
incoming call alert  
ringing tune  
ringing volume  
vibrating alert  
message alert tone  
keypad tones  
warning tones  
automatic answer\*\*  
alert for  
rename\*\*\*

\*only shown if the headset has been connected

\*\*only shown in headset

\*\*\*not available for general or headset profiles



alarm clock  
clock  
hide clock or show clock  
set the time  
time format  
call settings  
anykey answer  
automatic redial  
speed dialling  
call waiting service  
summary after call  
own number sending  
phone settings  
language  
screen saver delay (mm:ss)  
welcome note  
network selection  
confirm SIM service actions  
communication settings  
info service  
listen to voice messages  
voice mailbox number  
service command editor  
security settings\*  
restore default settings

\*For more information refer to "Chapter 06 Security information".

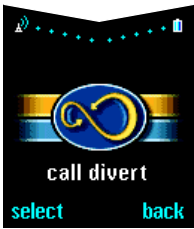

divert all voice calls  
divert if busy  
divert if not answered  
divert if out of reach  
divert if not available  
divert all fax calls  
divert all data calls  
cancel all divers



view day notes  
create note  
reminder  
call  
anniversary  
view by weeks  
go to date  
settings  
set the date  
set the time  
date format  
time format  
week starts on  
auto erase



(Network service)  
For more information refer to  
"SIM services" on page 3-40.

## USING THE MENUS

The features on your Vertu phone are organised in a series of menus.

### ACCESSING MENUS BY SCROLLING



> From the stand-by display, press **menu**.

> Scroll to the desired menu, for example **settings**.

> Press **select** to access the menu.

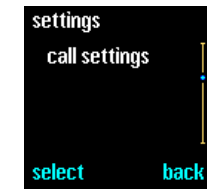
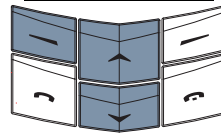

> Scroll to the desired submenu, for example **call settings**.

> Press **select** to access the submenu.

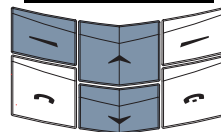

> A scroll bar indicates that you are in a list. The marker on the scroll bar indicates your position within that list.

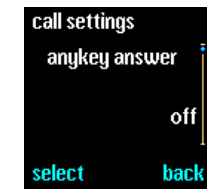

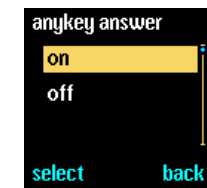
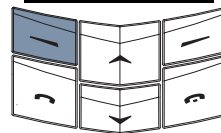

> Press **select** to access the next submenu, for example **anykey answer**.

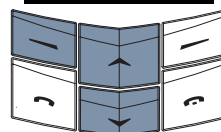

> Scroll to the desired option, for example **on** or **off**.

> Press **select**. A confirmation message appears.



 Press **back** to return to the previous menu or submenu without saving changes. Press the **END** key to return to the stand-by display without saving changes.



## MESSAGES

(Network service)

The messages feature allows you to write, send, receive and read text messages.

 Some service providers do not allow international sending or receiving of text messages. For more information contact your service provider.

### WRITING AND SENDING TEXT MESSAGES

The **write message** option allows you to write text messages. There are two ways to key in text:

- > Basic text input
- > Predictive text input

The number of characters you can send in a text message is dependent on your service provider. You can key in a maximum of 160 characters. The number of characters you have entered appears below the battery strength indicator.

### BASIC TEXT INPUT

To key in a character, press a **NUMBER** key once or several times, depending on which character you require. The table below lists the characters available on each **NUMBER** key and the order they appear when you press the **NUMBER** key multiple times.

|   |                                   |
|---|-----------------------------------|
| 1 | .,?!@'_()-;:&/~\%*#+<=>"'€£\$¥¤€ı |
| 2 | abc2äæåääããç                      |
| 3 | def3èéëèð                         |
| 4 | ghi4iïî                           |
| 5 | jkl5&                             |
| 6 | mno6öøóóôõñ                       |
| 7 | pqrs7B\$                          |
| 8 | tuv8úúúü                          |
| 9 | wxyz9ýþ                           |

To write a new message:

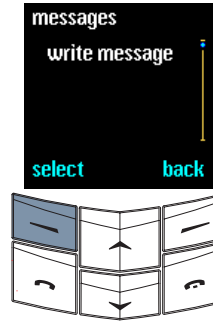

- > From the stand-by display, press **menu**. **messages** appears.
- > Press **select**. **write message** appears.
- > Press **select**.

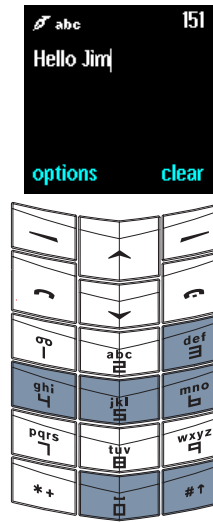

- Key in your text message, for example "Hello Jim", using the **NUMBER** keys, as follows:
- > Press the **4** key twice for "H".
- > Press the **3** key twice for "e".
- > Press the **5** key three times for "l".
- > Wait for the cursor to reappear and press the **5** key three times for "l".
- > Press the **6** key three times for "o".
- > Press the **0** (**ZERO**) key once to insert a space.
- > Press the **#** **↑** key to switch to upper case.
- > Press the **5** key once for "J".
- > Press the **#** **↑** key to return to lower case.
- > Press the **4** key three times for "i".
- > Press the **6** key once for "m".

Use the **scroll** keys to move the cursor through the text message.

Press **clear** at any time to erase the character before the cursor.

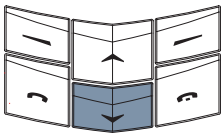

If the next letter you require is on the same key as the letter you have just keyed in, for example the second "l" in "Hello":

> Press the lower **scroll** key to move the cursor one character to the right and key in the second letter.

or

> Wait until the cursor reappears, then key in the second letter.



When writing a text message, press and hold **clear** to erase all text in your text message.

To switch between upper and lower case:

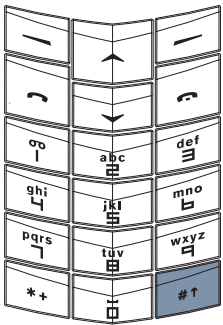

> Press the # ↑ key.

The icon **abc**, **abc** or **ABC** at the top of the display beneath the signal bars indicates the selected case.

To insert a number:

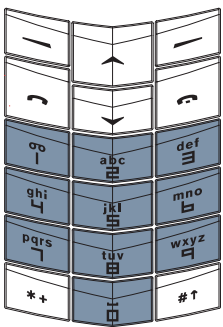

> Press and hold the required **NUMBER** key until the number appears.

To switch between letters and numbers:

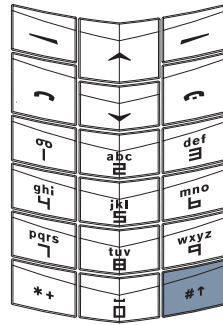

> Press and hold the # ↑ key.

The icon **123** at the top of the display beneath the signal bars indicates that you can key in a number.

To insert a symbol, for example a full stop, comma or currency symbol:

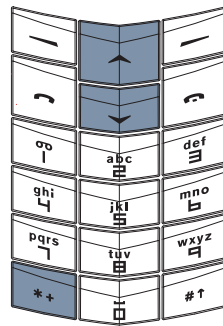

> Press the **1** key repeatedly to scroll through the available characters.

or

> Press the \* + key. A list of symbols appears.

> Scroll through the list to the desired character.

> Press **use** to insert the character.

The icon **?E** at the top of the display beneath the signal bars indicates that you can key in a symbol.

## BASIC TEXT INPUT OPTIONS

While writing or editing a text message using basic text input, the following options are available:

### send

Send a text message after you have written it.

> Press **options**. **send** is highlighted.

> Press **select**.

Either

> Key in the recipient's number and press **ok**.

or

> Press **search**.

> Scroll to a name in your directory and press **ok**.

> If the name in your directory has multiple numbers associated with it, scroll to the number and press **ok** twice.

A confirmation message is displayed to indicate that the text message has been sent by your Vertu phone to the message centre. This is not an indication that the text message has been received at the intended destination.



*You can also press the **SEND** key to send a text message after you have written it instead of using the options submenu.*

## send options

Send a text message to more than one person, or send a text message using a message profile.

To send a text message to more than one person:

> Press **options**.

> Scroll to **send options**.

> Press **select**. **multiple copies** is highlighted.

> Press **select** to display the list of names in your directory.

> Scroll to the desired name.

> Press **ok**.

> If the name in your directory has multiple numbers associated with it, scroll to the desired number and press **ok**. A confirmation message appears.

> Repeat the last three steps for all remaining people.

> Press **done** when you have finished.

To send a text message using a message profile:

> Press **options**.

> Scroll to **send options**.

> Press **select**.

> Scroll to **message profiles**.

> Press **select**. A list of available message profiles is displayed.

> Scroll to the desired profile.

> Press **select**.

For information on setting up message profiles, refer to "Message settings" on page 3-15.

- save message** Save a text message to the **outbox**. You can save a message before or after you have sent it.
- > Press **options**.
  - > Scroll to **save message**.
  - > Press **select**. A confirmation message appears.
- erase text** Clear all text from your text message.
- > Press **options**.
  - > Scroll to **erase text**.
  - > Press **select**.
- insert entry** Insert information from your directory into your text message.
- > Press **options**.
  - > Scroll to **insert entry**.
  - > Press **select**.
  - > Scroll to the required name.
  - > Press **options**. **insert name** is highlighted.
- Either
- > Press **select** to insert the name into your text message.
- or
- > Scroll to **view details**.
  - > Press **select**.
  - > If the name in your directory has multiple items associated with it, scroll to the desired item and press **select**. The item is inserted into your text message.
- insert number** Insert a number into your text message.
- > Press **options**.
  - > Scroll to **insert number**.
  - > Press **select**.
- Either
- > Key in the required number and press **ok**. The number is inserted into your text message.
- or
- > Press **search**.
  - > Scroll to the required name.
  - > Press **ok**.
  - > If the name in your directory has multiple numbers associated with it, scroll to the desired entry and press **ok**.
  - > Press **ok**. The number is inserted into your text message.
- insert template** Insert template text into your text message.
- > Press **options**.
  - > Scroll to **insert template**.
  - > Press **select**.
  - > Scroll to the required template.
  - > Press **select**.
- For more information refer to "Templates" on page 3-13.
- exit** Exit the text message you are writing. The text message is automatically saved to the outbox.
- > Press **options**.
  - > Scroll to **exit**.
  - > Press **select**. A confirmation message appears. Your text message is saved to your outbox, and **write message** appears.

## PREDICTIVE TEXT INPUT

Predictive text reduces the number of key presses required to key in a word. As you key in characters, predictive text attempts to match the characters to a word in the built-in dictionary.

Before you can use predictive text input, you must select the language for predictive text.



- > From the stand-by display, press **menu**. **messages** appears.
- > Press **select**. **write message** appears.
- > Press **select**.
- > Press **options**.
- > Scroll to **dictionary**.
- > Press **select**.



- > Scroll to the desired language. Select **dictionary off** to disable predictive text input.
- > Press **select**. A confirmation message appears.

 *Predictive text is only available for languages listed in the **dictionary** submenu.*

Once enabled, press # **↑** to switch between predictive text input and basic text input modes when keying in your message.

When using predictive text input, instead of pressing a **NUMBER** key two or three times to insert a character as in basic text input, press the required **NUMBER** key once only, regardless of the position of that character on the **NUMBER** key list. As you key in characters, the characters are underlined to indicate that predictive text input is attempting to guess the word.

The example below describes how to key in "Vertu".

 *When keying in a word, the characters on the display may not be part of the desired word. As you continue keying in characters, the word displayed becomes more accurate.*



- > Press the **8** key for "V".
- > Press the **3** key for "e".
- > Press the **7** key for "r".
- > Press the **8** key for "t".
- > Press the **8** key for "u".

Press **clear** at any time to erase the character before the cursor.

To search for the desired word, if the word on the display is not correct after you have keyed it in:

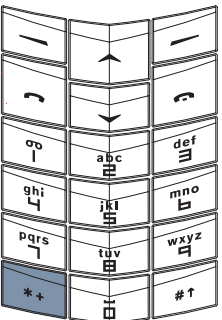

- > Press the \* + key repeatedly until the desired word appears.
- or
- > Press **options**.
- > Scroll to **next match**.
- > Press **select**. The next match replaces the incorrect word on the display.

If the desired word does not appear, press **previous** to insert the previous word into the text message.

If a word is not recognised, a question mark appears at the end of the text you have just keyed in. An audible alert also sounds if your Vertu phone is set up for audible alerts.

To insert the desired word into your text message and add it to the predictive text dictionary:

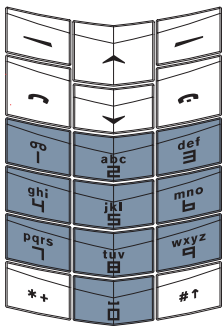

- > Press **spell**.
- > Key in the desired word. The basic text input method is automatically used when adding a new word to the dictionary.
- > Press **save**. The new word appears in your text message.

The next time you use predictive text input, the new word will be recognised.

To confirm a word by inserting a space:

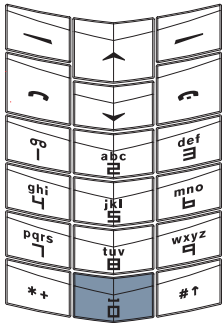

- > Press the 0 (ZERO) key once.

To confirm a word without inserting a space:

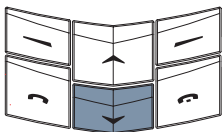

- > Press the lower **scroll** key.
- You can now key in the next word. This can be useful when entering long words that are formed of two (or more) shorter words.

To confirm a word by inserting a symbol, for example a full stop, comma or currency symbol:

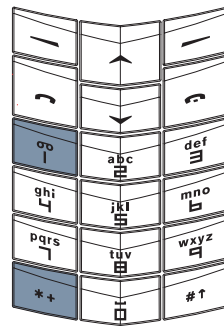

- Either
- > Press the 1 key. A full stop appears.
- or
- > Press the \* + key repeatedly to scroll through a list of the most common symbols.
- If the symbol you require is not in the list of the most common symbols, **options** changes to **symbol** after you have scrolled through the list.
- > Press **symbol**.

- > Scroll through the list to the desired symbol.
  - > Press **use** to insert the symbol.
- or
- > Press and hold the \* + key. A list of symbols appears.
  - > Scroll through the list to the desired symbol.
  - > Press **use** to insert the symbol.

You can now insert a space or key in the next word.

PREDICTIVE TEXT INPUT OPTIONS

When writing or editing a text message using predictive text input, the options are the same as for basic text input, with two additions. These options are accessed as follows:

- insert word** Add a new word to the text message and dictionary.
- > Press **options**.
  - > Scroll to **insert word**.
  - > Press **select**.
  - > Key in the desired word.  
The input method reverts to basic text input, while adding a new word to the dictionary.
  - > Press **save**. The new word is inserted into your text message.

The next time you use predictive text input, the new word will be recognised.

- insert symbol** Add a symbol to your text message.
- > Press **options**.
  - > Scroll to **insert symbol**.
  - > Press **select**.
  - > Scroll through the list to the desired symbol.
  - > Press **use** to insert the symbol into your text message.

READING TEXT MESSAGES

When you receive a text message, an information note and an envelope icon appear on the display below the signal strength and battery indicators. By default a received text message is accompanied by an audible alert. If your screen saver is active when a message is received, the alert bar will be activated.

 *A flashing envelope icon on the stand-by display indicates that the message memory is full. Before you can receive or send any more text messages you must erase some of your existing text messages or move them to a personal folder.*

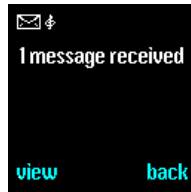

- > Press **view** to read the text message immediately.
- > Scroll through the whole text message.
- or
- > Press **back** to read the text message later.

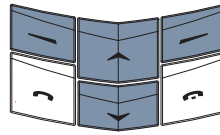

To read the text message later:

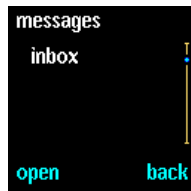

- > From the stand-by display, press **menu.messages** appears.
- > Press **select**.
- > Scroll to **inbox**.
- > Press **open**. The most recent text message is highlighted.

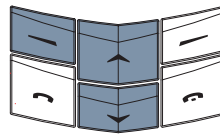

- An unread text message has an envelope icon in front of it.
- > Press **select** to read the text message.

You can also open and read text messages stored in your text message folders. For more information see "Text message folders" on page 3-12.

 *Occasionally you might receive a text message containing unrecognised characters. These characters appear as □. This does not affect the operation of your Vertu phone in any way and you can still reply to, or forward, the text message.*

## MESSAGE READING OPTIONS

While reading a text message stored in the **inbox** folder, **outbox** folder, **archive** folder, or any personal folders in the **personal folders** folder, several options are available and are accessed as follows:

### erase

Erase the text message.

> Press **options**. **erase** is highlighted.

> Press **select**.

> Press **ok**. A confirmation message appears.

### reply

Reply to the sender of the text message. This option only appears if you are reading a message you have received.

> Press **options**.

> Scroll to **reply**.

> Press **select**.

> Scroll to one of the following reply types:

**empty message** – do not include the original text message at the beginning of the reply.

**original message** – include the original text message at the beginning of the reply.

**Yes, No** or one of the other standard answers – insert one of the standard answers from the list.

**template** – include the selected template at the beginning of the reply.

> Press **select**.

> Create or edit the text message as required.

> Send the text message. For more information see "Writing and sending text messages" on page 3-3.

## forward

Send the text message to another person.

This option appears as **send** if you are reading a text message that you have keyed in.

> Press **options**.

> Scroll to **forward**.

> Press **select**.

Either

> Key in the recipient's number.

> Press **ok**. A confirmation message appears.

or

> Press **search**.

> Scroll to a name in your directory.

> Press **ok**.

> If the name in your directory has multiple numbers associated with it, scroll to the desired number and press **ok**.

> Press **ok**. A confirmation message appears.

## forward options

Send the text message to more than one person, or forward a text message using a message profile.

This option changes to **send options** if you are reading a message you have received.

To send a text message to more than one person:

> Press **options**.

> Scroll to **forward options**.

> Press **select**. **multiple copies** is highlighted.

> Press **select** to access the list of names in your directory.

> Scroll to the desired name.

> Press **ok**.



- > If the name in your directory has multiple numbers associated with it, scroll to the desired number and press **ok**.
- > Repeat the last three steps for all remaining recipients.
- > Press **done** when you have finished.

For information on setting up message profiles, see "Message settings" on page 3-15.

**move**

Move the text message to another folder.

- > Press **options**.
- > Scroll to **move**.
- > Press **select**.
- > Scroll to one of the following: **inbox**, **outbox**, **archive**, **templates** or a folder you have created in **personal folders**.

- > Press **ok**. A confirmation message appears.

**edit**

Edit the text message. For more information see "Writing and sending text messages" on page 3-3.

**change title**

Change the title of the text message.

- > Press **options**.
- > Scroll to **change title**.
- > Press **select**.
- > Edit the title as required.
- > Press **ok**. A confirmation message appears.

**copy to agenda**

Copy the text message into your agenda as an agenda note.

- > Press **options**.
- > Scroll to **copy to agenda**.
- > Press **select**. A confirmation message appears.

The text message is saved in your agenda as a reminder for the current day, with a reminder time of 9am.

For more information see "Agenda" on page 3-31.

**use number**

Save, send a text message to, or call any number in the text message.

- > Press **options**.
- > Scroll to **use number**.
- > Press **select**. If there is more than one number in the text message, scroll to the required number.
- > Press **options**. **save** is highlighted.

To save a number in the text message to your directory as a new entry:

- > Press **select**.
- > Key in the name you want to save with the number.

- > Press **ok**. A confirmation message appears.

To add a number in the text message to an entry in your directory, if you are using the phone memory:

- > Scroll to **add to entry**.
- > Press **select**.
- > Scroll through the list of names in your directory.
- > Press **add no..**
- > Scroll to the number type.
- > Press **select**. A confirmation message appears.

If the entry already has the maximum number of items associated with it, you are asked if you want to save the name and number to the SIM memory.

- > Press **yes** to save the name and number to the SIM memory.

or

- > Press **no** to cancel.

To send a text message to the number in your message:

- > Scroll to **send message**.

- > Press **select**.

- > Key in your text message. For more information see "Writing and sending text messages" on page 3-3.

To call a number in your message:

- > Scroll to **call**.

- > Press **select**.

or

- > Press the **SEND** key.

## details

View details of the sender of the text message, their number, the date and time the text message was sent, and the message centre number. This option only appears if you are reading a message you have received.

- > Press **options**.

- > Scroll to **details**.

- > Press **select**.

- > Use the **SCROLL** keys to view all the details of the text message.

## TEXT MESSAGE FOLDERS

All text messages stored in your Vertu phone are organised in folders.

### INBOX

Text messages are automatically stored in the **inbox** folder when they are first received, and remain in the **inbox** folder until you move or delete them.

To access the **inbox** folder:

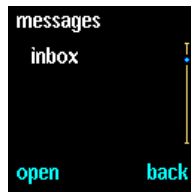

- > From the stand-by display, press **menu.messages** appears.

- > Press **select**.

- > Scroll to **inbox**.

- > Press **open**.

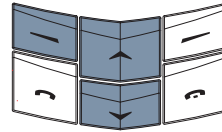

- An unread text message has an envelope icon in front of it.

### OUTBOX

When you save a text message that you have written, it is saved in the outbox folder.

To access the **outbox** folder:

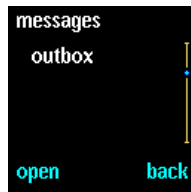

- > From the stand-by display, press **menu.messages** appears.

- > Press **select**.

- > Scroll to **outbox**.

- > Press **open**.

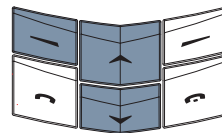

## ARCHIVE

The archive folder is a place to store text messages that you want to save for a long time. The archive folder holds your text messages until you erase them.

To access the **archive** folder:

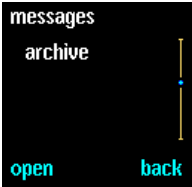

> From the stand-by display, press **menu. messages** appears.

> Press **select**.

> Scroll to **archive**.

> Press **open**.

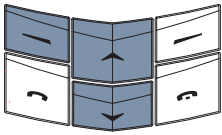

*A flashing envelope icon on the stand-by display indicates that the message memory is full. Before you can receive or send any more text messages you must erase some of your existing text messages or move them to a personal folder.*

## TEMPLATES

The **templates** folder contains a list of pre-written standard messages for sending or replying to text messages. You can include a template in a text message while you are writing it, and edit the template text.

To edit a template:

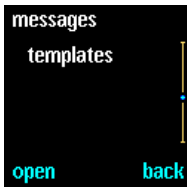

> From the stand-by display, press **menu. messages** appears.

> Press **select**.

> Scroll to **templates**.

> Press **open**.

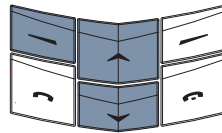

> Scroll to the required template, for example **I will be arriving at**.

> Press **select**.

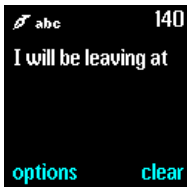
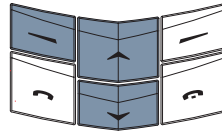

> Press **options**.

> Scroll to **edit**.

> Press **select**.

Change "arriving" to "leaving".

> Use the **SCROLL** keys to move the cursor after "arriving".

> Press **clear** repeatedly to erase the word "arriving".

> Key in the word "leaving".

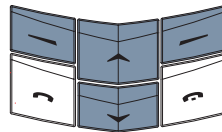



- > Press **options**.
- > Scroll to **save message**.
- > Press **select**. A confirmation message appears.

The edited template is available in the **templates** folder the next time you want to write or reply to a text message.

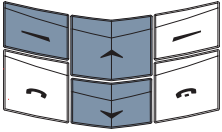

 When you select **restore default settings** from the **settings** menu, the original template text is restored. For more information, see "Restore default settings" on page 3-29.

**PERSONAL FOLDERS**

You can create your own folders for storing and organising text messages, and then rename or erase them as required.

To access the **personal folders** submenu:

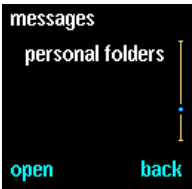

- > From the stand-by display, press **menu**. **messages** appears.
- > Press **select**.
- > Scroll to **personal folders**.
- > Press **open**.

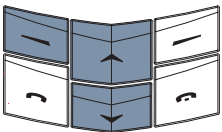

The first time you access the **personal folders** submenu, the folder will be empty and **add folder** is the only option available.

**add folder**

- Add a new folder to the **personal folders** folder.
- > Press **options**. **add folder** is highlighted.
- > Press **select**.
- > Key in the name of the new folder. The input method reverts to basic text input.
- > Press **ok**. A confirmation message appears.

You can now move text messages to the new folder. For more information on moving text messages see "Message reading options" on page 3-10.

After you have added folders, several options are available from the **personal folders** submenu:

**open folder**

- Open a personal folder.
- > Scroll through the list of personal folders to the required folder.
- > Press **options**. **open folder** is highlighted.
- > Press **select**. A list of the text messages in the folder appears, if you have moved any text messages to the folder.

**rename folder**

- Change the name of a personal folder.
- > Scroll to the required folder name.
- > Press **options**.
- > Scroll to **rename folder**.
- > Press **select**.
- > Edit the folder name as desired.
- > Press **ok**. A confirmation message appears.

**erase folder**

Remove a folder from the **personal folders** folder.

- > Scroll to the required folder name.
- > Press **options**.
- > Scroll to **erase folder**.
- > Press **select**.
- > Press **ok**. If the folder is empty, a confirmation message appears.
- > If the folder contains text messages, you are prompted to confirm that you want to erase the folder. Press **ok**. A confirmation message appears.



*When you erase a folder, all the text messages in that folder are also erased.*

**ERASING MULTIPLE TEXT MESSAGES**

You can erase all text messages you have read from any of the standard or personal folders, or from all the folders at once.

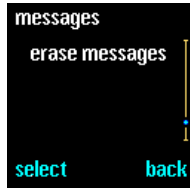

- > From the stand-by display, press **menu.messages** appears.
- > Press **select**.
- > Scroll to **erase messages**.

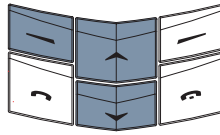

- > Press **select**.

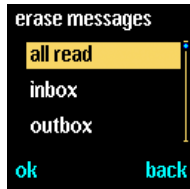

- To erase all read text messages from an individual folder:
- > Scroll to the required folder's name.
- > Press **ok**.

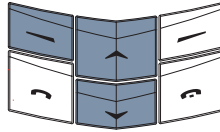

- > Press **ok** to confirm. A confirmation message appears.

To erase all read text messages in all the folders:

- > Scroll to **all read**.
- > Press **ok**.
- > Press **ok** to confirm. A confirmation message appears.

**MESSAGE SETTINGS**

When you write or reply to a text message, your Vertu phone uses a default message profile. You can edit the profile in the **message settings** submenu.

To access the message settings list:

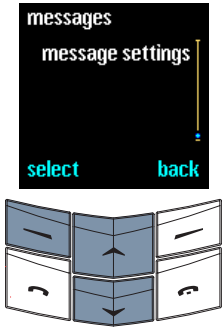

- > From the stand-by display, press **menu**. **messages** appears.
- > Press **select**.
- > Scroll to **message settings**.
- > Press **select**.

Several options are available and are accessed as follows:

**message centre number**

This is usually provided by your service provider and stored in your SIM card.

- > Press **select**. **message centre number** appears. You can edit the **message centre number**.

Check with your service provider before changing this number.

**messages sent as**

Choose the default format setting of text messages you send.

- > Scroll to **messages sent as**.
- > Press **select**.
- > Scroll to one of the following: **text**, **e-mail**, **paging** or **fax**.
- > Press **ok**. A confirmation message appears.

For more information on the format of text messages contact your service provider.

**message validity**

Choose how long the network keeps trying to deliver a text message you have sent, if the network was unable to deliver it immediately.

- > Scroll to **message validity**.
- > Press **select**.
- > Scroll to one of the following: **1 hour**, **6 hours**, **24 hours**, **3 days**, **1 week** or **maximum**.
- > Press **ok**. A confirmation message appears.

**default recipient number**

This setting is normally blank by default but may be useful when setting message profiles.

- > Scroll to **default recipient number**.
- > Press **select**.

**delivery reports**

Choose to receive a text message report from the network when a text message you have sent has been delivered to the recipient.

- > Scroll to **delivery reports**.
- > Press **select**.
- > Scroll to **on** or **off**.
- > Press **ok**. A confirmation message appears.

**reply to you via same centre**

The recipient of your text message can reply to you via your own message centre. This option is a more efficient way of receiving text messages when in another network area, typically when you are abroad.

- > Scroll to **reply to you via same centre**.
- > Press **select**.
- > Scroll to **yes** or **no**.
- > Press **select**. A confirmation message appears.

The default setting is **no**. Check with your service provider before changing this setting.

**message profiles**

Create or edit a set of message settings, for example one for sending text messages and another for sending e-mails.

- > Scroll to **message profiles**.
- > Press **select**.
- > Scroll to the profile you want to edit.
- > Press **select**.
- > Edit the profile settings as described above.

You can also edit the name of the message profile.

**CALL REGISTER**

The call register feature allows you to view information about calls that you have missed, received and made.

To access the **call register** feature:

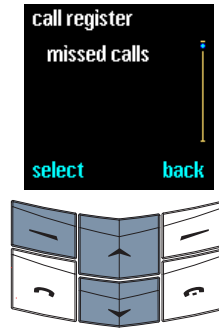

- > Press **menu**.
- > Scroll to **call register**.
- > Press **select**.
- > Use the **SCROLL** keys to view the submenus, for example **missed calls**.

Several options are available and are accessed as follows:

- missed calls** (Network service) View a list of the most recent unanswered calls. **missed calls** appears after you access the call register menu.
  - > Press **select**.



*If you miss an incoming call, an information note appears on the stand-by display. Press **list** to view the **missed calls** list or press **back** to remove the information note from the display.*

- received calls** (Network service) View a list of the most recent answered calls.
  - > Scroll to **received calls**.
  - > Press **select**.



*If the caller's number is not available, for example if the caller withheld their number or the network did not transmit the number, **(no number)** appears in the **missed calls** or **received calls** list. Consequently, some of the options described may not be available.*

- dialled numbers** View a list of the most recent dialled numbers.
  - > Scroll to **dialled numbers**.
  - > Press **select**.

When viewing calls in the **missed calls, received calls** and **dialled numbers** call lists, several options are available and are accessed as follows:

**time of call** View the time and date of the call.

- > Press **options**. **time of call** is highlighted.
- > Press **select**.

**edit number** Edit the number in the list. You can then either save the edited number, call the number or send a text message.

- > Press **options**.
- > Scroll to **edit number**.
- > Press **select**.
- > Use the **scroll** keys to move the cursor and edit the number as required.

To save the edited number:

- > Press **options**. **save** is highlighted.
- > Press **select**.
- > Key in the name to save with the number.
- > Press **ok**. A confirmation message appears.

To add the edited number to an entry in your directory, if you are using phone memory:

- > Press **options**.
- > Scroll to **add to entry**.
- > Press **select**.
- > Scroll through the list of names in your directory.
- > Press **add no..**
- > Select the number type.
- > Press **select**. A confirmation message appears.

If the entry already has the maximum number of items associated with it, you are prompted to save the name and number to the SIM memory.

- > Press **yes** to save the name and number to the SIM memory.
- or
- > Press **no** to cancel.

To send a text message to the edited number:

- > Press **options**.
- > Scroll to **send message**.
- > Press **select**.
- > Key in the text message. For more information see "Writing and sending text messages" on page 3-3.

To call the edited number:

- Either
- > Press the **send** key.
  - or
  - > Press **options**.
  - > Scroll to **call**.
  - > Press **select**.

**save** Save the number to your directory.

- > Scroll to **save**.
- > Press **select**.
- > Key in the name to save with the number.
- > Press **ok**. A confirmation message appears.

**erase** Erase the number from the call list.

- > Scroll to **erase**.
- > Press **select**.
- > Press **ok**. A confirmation message appears.

**view number** View the number, for example, before returning a call.

- > Scroll to **view number**.
- > Press **select**.



ADDITIONAL CALL REGISTER OPTIONS

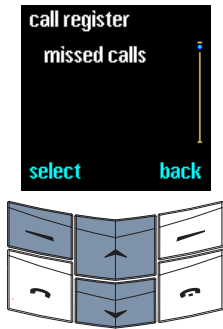

- > Press **menu**.
- > Scroll to **call register**.
- > Press **select**.
- > Use the **scroll** keys to view the submenus.

**erase call lists**

Erase all numbers listed in the **missed calls**, **received calls** and **dialled numbers** submenus. You cannot undo this operation.

To erase a call list or lists:

- > Scroll to **erase call lists**.
- > Press **select**.
- > Scroll to one of the following: **all**, **missed**, **dialled** or **received**.
- > Press **select** to erase the numbers. A confirmation message appears.

**call duration**

View the duration of your incoming and outgoing calls.

- > Scroll to **call duration**.
- > Press **select**.
- > Scroll to one of the following: **last call duration**, **all calls duration**, **received calls duration**, **dialled calls duration** or **clear timers**.

When you select **clear timers**, you will need to key in the phone security code. For more information refer to "Security code" on page 6-3.

**call costs**

(Network service)

Check the cost of all calls or your last call.

- > Scroll to **call costs**.
- > Press **select**.
- > Scroll to **last call units** or **all calls units**.
- > Press **options**.
- > Scroll to **clear counters**, **show cost** or **call cost limit**.
- > Press **select**.

For more information about call costs contact your service provider.



*The actual invoice for calls and services from your service provider may vary, depending on network features, rounding off for billing, taxes and so forth.*



*Some timers, may be reset during service or software upgrades.*

## PROFILES

The **profiles** feature allows you to set up different audible alerts. Six profiles are available on your Vertu phone.

### PROFILE ICONS

To help you identify which profile is active, one of the following icons appear in the stand-by display, below the signal strength indicator.

 **general**

 **silent**

 **soft**

 **loud**

 **pager**

 **headset.** Only available after the Vertu headset has been connected for the first time.

### ACTIVATING A PROFILE



From the stand-by display, press **menu**.

Scroll to **profiles**.

Press **select**.

Scroll to the required profile.

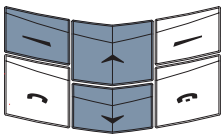

Press **options**. **activate** is highlighted.



Press **ok**. A confirmation message appears.

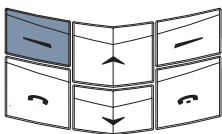

To change a profile from the stand-by display:

- > Press the **POWER** key once briefly.
- > Scroll to the desired profile.
- > Press **ok**. A confirmation message appears.

### PERSONALISING A PROFILE



From the stand-by display, press **menu**.

Scroll to **profiles**.

Press **select**.

Scroll to the desired profile.

Press **options**.

Scroll to **personalise**.

Press **ok**.

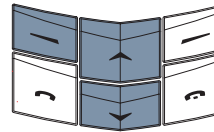

Several options are available and are accessed as follows:

- incoming call alert** Set the type of audible alert your Vertu phone uses to alert you of an incoming call. **incoming call alert** appears after you access the **personalise** submenu.
  - > Press **select**.
  - > Scroll to one of the following: **ringing**, **ascending**, **ring once**, **beep once** or **off** (no audible alert for an incoming call).
  - > Press **select**. A confirmation message appears.

**ringing tune**

Set the ringing tune your Vertu phone uses to alert you of an incoming call.

- > Scroll to **ringing tune**.
- > Press **select**.
- > Scroll through the ringing tunes, pausing at each name to hear the tune.
- > Scroll to the desired ringing tune.
- > Press **ok**. A confirmation message appears.

**ringing volume**

Set the volume of the incoming call alert.

- > Scroll to **ringing volume**.
- > Press **select**.
- > Scroll to the desired level, from 1 to 5.
- > Press **ok**. A confirmation message appears.

**vibrating alert**

Set whether your Vertu phone vibrates when you receive an incoming call or text message.

- > Scroll to **vibrating alert**.
- > Press **select**.
- > Scroll to **on** or **off**.
- > Press **ok**. A confirmation message appears.

**message alert tone**

Set the audible alert your Vertu phone uses when you receive a text message.

- > Scroll to **message alert tone**.
- > Press **select**.
- > Scroll to one of the following: **off**, **standard**, **special**, **beep once** or **ascending**.

To hear the message alert tones, pause at each name while scrolling through the list.

- > Press **ok**. A confirmation message appears.

**keypad tones**

Set the volume of the keypad tones when pressing the keys on the keypad and the volume key.

- > Scroll to **keypad tones**.
- > Press **select**.
- > Scroll to the desired level, or **off**.
- > Press **ok**. A confirmation message appears.

**warning tones**

Set whether your Vertu phone uses an audible alert for giving you warnings, for example when the battery is low.

- > Scroll to **warning tones**.
- > Press **select**.
- > Scroll to **on** or **off**.
- > Press **ok**. A confirmation message appears.

- automatic answer** Set whether calls are answered automatically when the headset is connected. Only available in the **headset** profile.
- > Scroll to **automatic answer**.
  - > Press **select**.
  - > Scroll to **on** or **off**.
  - > Press **ok**. A confirmation message appears.

- alert for** Set which caller groups you want your Vertu phone to alert you for when you receive a call from someone added to a specified group. When you receive a call from someone who is not added to a specified caller group, a calling message appears on the display, but your Vertu phone remains silent.
- > Scroll to **alert for**.
  - > Press **select**.
  - > Scroll to the desired caller group.
  - > Press **mark** or **unmark** to select or deselect the caller group.
  - > Press **back**.
  - > Press **yes** to save changes or **no** to return to the previous menu without saving changes.

RENAMING A PROFILE

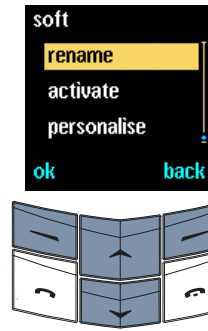

- > From the stand-by display, press **menu**.
- > Scroll to **profiles**.
- > Press **select**.
- > Scroll to the required profile.
- > Press **options**.
- > Scroll to **rename**.
- > Press **ok**.
- > Press **clear** as many times as needed to delete the character before the cursor.
- > Key in the new name.
- > Press **ok**. A confirmation message appears.



*You cannot rename the **general** or **headset** profiles.*

SETTINGS

The **settings** feature allows you to set up your Vertu phone to your preference.



ALARM CLOCK

You can use the **alarm clock** function to set an audible alert at a specified time during the next 24 hours. The alarm will sound, provided the time has been set on your Vertu phone and the battery is sufficiently charged. For more information see "Changing the time" on page 3-24.

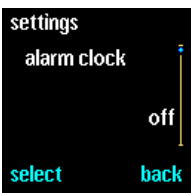
To set the alarm:

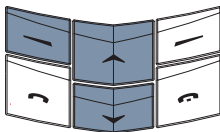

- > From the stand-by display, press **menu**.
- > Scroll to **settings**.
- > Press **select**. **alarm clock** appears.
- > Press **select**.

- > Key in the alarm time using the **NUMBER** keys.
- > Use the **SCROLL** keys to toggle between hour and minutes.
- > Press **ok**.



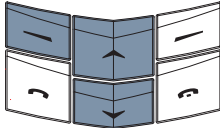

If the clock is set to the 12-hour format, the following screen also appears:

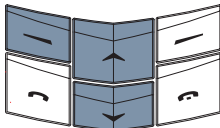

- > Scroll to **am** or **pm**.
- > Press **ok**. A confirmation message appears.



On the stand-by display, an indicator icon  appears beneath the battery and signal indicators to show that the alarm has been set.

 *If you set the alarm clock and then switch off your Vertu phone, the alarm will still sound at the time set, provided your battery is adequately charged. This can be particularly useful when you want to use the alarm clock function but do not want to receive calls.*

At the specified time, an audible alert sounds and the alarm time and display lights flash.

To pause the alarm when it sounds:

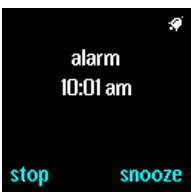

- Either
- > Press **snooze**. After five minutes the alarm sounds again.
- or
- > Press any other key except **stop** or the **END** key. After five minutes the alarm sounds again.

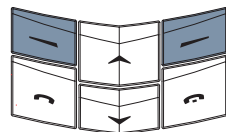

If your Vertu phone was on when the alarm sounded, a confirmation message appears.

If your Vertu phone was off when the alarm sounded, the phone remains switched off.

To switch off the alarm when it sounds:

> Press **stop**.



- If your Vertu phone was off when the alarm sounded, you can choose whether to switch the phone on or keep it off.
- > Press **yes** to switch the phone on. Do not press **yes** when wireless phone use may cause interference or danger.
- or
- > Press **no** to keep the phone switched off.

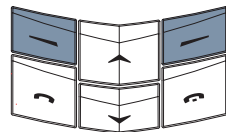



To unset the alarm at any time:

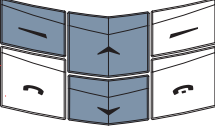

alarm clock  
off  
on  
ok back

- > From the stand-by display, press **menu**.
- > Scroll to **settings**.
- > Press **select**. **alarm clock** appears.
- > Press **select**.
- > Scroll to **off**.
- > Press **ok**. A confirmation message appears.



 *The alarm will sound even if you have switched off warning tones.*

#### CLOCK

The clock is used on the stand-by display, and in several other features on your Vertu phone, such as **messages**, **call register**, **alarm clock** and **agenda**.

 *The time must be set in order for the above features to work correctly.*

To show or hide the clock on the stand-by display:



clock  
hide clock  
set the time  
time format  
select back

- > From the stand-by display, press **menu**.
- > Scroll to **settings**.
- > Press **select**.
- > Scroll to **clock**.
- > Press **select**.

If the clock currently appears on the stand-by display, **hide clock** appears.

- > If the clock currently does not appear on the stand-by display, **show clock** appears.
- > Press **select**. A confirmation message appears.

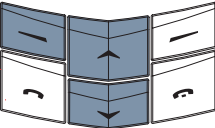

#### CHANGING THE TIME



clock  
set the time  
time format  
show clock  
select back

- > From the stand-by display, press **menu**.
- > Scroll to **settings**.
- > Press **select**.
- > Scroll to **clock**.
- > Press **select**.
- > Scroll to **set the time**.
- > Press **select**.

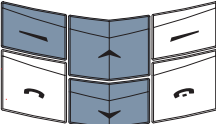

> Key in the correct time.  
> Use the **SCROLL** keys to toggle between hour and minutes.

See the examples below.

Set the time to 08:30:



time  
:00  
ok back

- > Key in "8".
- > Scroll to minutes. The leading zero is added.
- > Key in "30".
- > Press **ok**.

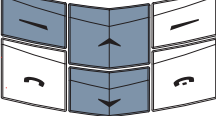

Set the time to 12:30:

- > Key in "12". The cursor automatically jumps to the minutes.

- > Key in "30".

- > Press **ok**.

If the clock is set to the 12-hour format, the following screen also appears:



time of day  
pm  
am  
ok back

- > Scroll to **am** or **pm**.
- > Press **ok**. A confirmation message appears.



 *If the battery is removed from your Vertu phone for longer than two hours, you may need to set the time and date again.*

## SETTING THE TIME FORMAT

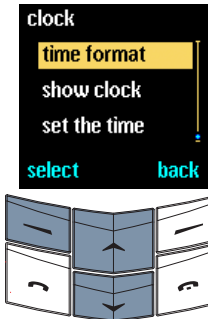

- > From the stand-by display, press **menu**.
- > Scroll to **settings**.
- > Press **select**.
- > Scroll to **clock**.
- > Press **select**.
- > Scroll to **time format**.
- > Press **select**.



- > Scroll to **12-hour** or **24-hour**.
- > Press **ok**. A confirmation message appears.

## CALL SETTINGS

The **call settings** submenu allows you to set up the way your Vertu phone operates when making and receiving calls.

To access the **call settings** submenu:

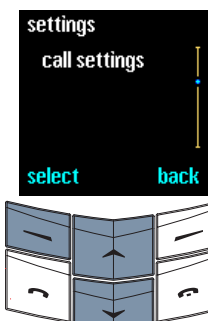

- > From the stand-by display, press **menu**.
- > Scroll to **settings**.
- > Press **select**.
- > Scroll to **call settings**.
- > Press **select**.

Several options are available and are accessed as follows:

**anykey answer** Answer incoming calls by pressing any key, except the **POWER** key or the **END** key. **anykey answer** appears after you access the **call settings** submenu.

- > Press **select**.
- > Scroll to **on** or **off**.
- > Press **select**. A confirmation message appears.

**automatic redial** Automatically make up to 10 attempts to connect a call if the network is busy or fails to connect when you try to make a call.

- > Scroll to **automatic redial**.
- > Press **select**.
- > Scroll to **on** or **off**.
- > Press **select**. A confirmation message appears.

**speed dialling** Enable single key dialling, where you can quickly dial a number by pressing and holding a single key.

- > Scroll to **speed dialling**.
- > Press **select**.
- > Scroll to **on** or **off**.

Refer to "Speed dialling" on page 4-1 for more information.

**call waiting service**  
(Network service)

Request the network to notify you of an incoming call while you have a call in progress. For more information see "Call waiting" on page 4-3.

**summary after call**

Briefly display the duration of a call after it has been disconnected.

- > Scroll to **summary after call**.
- > Press **select**.
- > Scroll to **on** or **off**.
- > Press **select**. A confirmation message appears.

**own number sending**  
(Network service)

Request the network to display your number to the person you are calling.

- > Scroll to **own number sending**.
- > Press **select**.
- > Scroll to one of the following: **set by network**, **on** or **off**.

For more information contact your service provider.

PHONE SETTINGS

The **phone settings** submenu allows you to set up the language used on your Vertu phone, change the screen saver delay time and manage the way it interacts with the network.

To access the **phone settings** submenu:

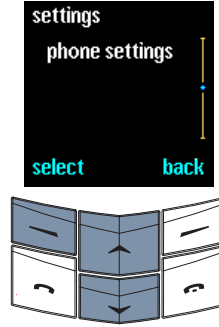

- > From the stand-by display, press **menu**.
- > Scroll to **settings**.
- > Press **select**.
- > Scroll to **phone settings**.
- > Press **select**.

Several options are available and are accessed as follows:

**language**

Set up the display language for your Vertu phone.

**language** appears after you access the **phone settings** submenu.

- > Press **select**.
- > Scroll to the desired language, or **automatic**.
- > Press **select**. A confirmation message appears.

If you select **automatic**, the language used is defined by the language of the SIM card currently in your Vertu phone. Changing the language setting may also change the time and date formats, depending on the language you selected.

 *If you insert a SIM card that uses a language not supported by your Vertu phone, the display language is English.*



**screen saver delay (mm:ss)**

The screen saver is automatically displayed after a period of keypad inactivity. To set the screen saver delay time:

- > Scroll to **screen saver delay (mm:ss)**.
- > Press **select**.
- > Enter the delay time in minutes and seconds. Use the scroll keys to toggle between minutes and seconds.

The minimum delay is 25 seconds and the maximum is 60 minutes.

**welcome note**

Display a personalised message when your Vertu phone is switched on.

Key in a message of up to 44 characters to appear briefly when your Vertu phone is switched on.

- > Scroll to **welcome note**.
- > Press **select**.
- > Key in your personalised message, up to 44 characters in length.

To save the personalised message:

- > Press **options. save** is highlighted.
- > Press **select** to save the message. A confirmation message appears.

To erase a personalised message:

- > Press **options**.
- > Scroll to **erase**.
- > Press **select**. A confirmation message appears.

**network selection**

Set how your Vertu phone selects the network operator for your current location.

**manual** allows you to select a network operator from the list of operators available in your current location.

**automatic** allows your Vertu phone to select the network operator that provides the best signal in your current location.

- > Scroll to **network selection**.
- > Press **select. automatic** is highlighted.

Either

- > Press **select**. A confirmation message appears.

or

- > Scroll to **manual**.
- > Press **select**. A list of available networks appears after a period of time.
- > Scroll to the name of your preferred network operator.
- > Press **select**. A confirmation message appears.



*Your Vertu phone operates on the GSM 900MHz and 1900MHz networks. Your Vertu phone will not operate on the 850MHz GSM network in the USA.*

COMMUNICATION SETTINGS

The **communication settings** submenu allows you to set up some of the network services which may be offered by your service provider.

To access the **communication settings** submenu:

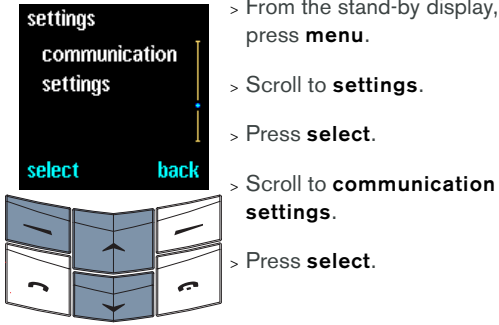

Several options are available and are accessed as follows:

**info service**  
(Network service)

Set up your Vertu phone to receive automated text messages from your service provider.

**info service** appears after you access the **communication settings** submenu.

To receive automated text messages on active topics in the topic index:

- > Press **select**.
- > Scroll to **on**.
- > Press **ok**. A confirmation message appears.

To add new topics to the topic index:

- > Scroll to **topics**.
- > Press **ok**. **add** is highlighted.
- > Press **ok**.
- > Key in the topic number.
- > Press **ok**.
- > Key in the topic name.
- > Press **ok**. A confirmation message appears.

To activate topics:

- > Scroll to **topic index**. A list of available topics from the network appears.
- > Press **ok**. A confirmation message appears.

To select the language or languages for automated text messages:

- > Scroll to **language**.
- > Press **ok**.
- > Scroll to the desired language.
- > Press **mark** or **unmark** to select or deselect a language.
- > Press **back**.
- > Press **yes** to save changes or **no** to return to the previous menu without saving changes.



*You can save info service messages in one of the folders you created using the **personal folders** option.*

**listen to voice messages**  
(Network service)

Call your voice mailbox to listen to your voice messages.

- > Scroll to **listen to voice messages**.
- > Press **ok**.

If your voice mailbox number has been stored, your Vertu phone dials the number.

If your voice mailbox number has not been stored, you are prompted to key in your voice mailbox number.

**voice mailbox number**

Store or edit your voice mailbox number.

- > Scroll to **voice mailbox number**.
- > Press **select**.
- > Key in your voice mailbox number, as required.

Press **clear** at any time to erase the character before the cursor.

- > Press **ok**. A confirmation message appears.

For more information about your voice mailbox number contact your service provider.

**service command editor**

Send service requests to your service provider.

- > Scroll to **service command editor**.
- > Press **select**.
- > Key in your request.
- > Press **send**. A confirmation message appears.

For more information contact your service provider.

**SECURITY SETTINGS**

The **security settings** submenu allows you to set up the security features on your Vertu phone. For more information refer to "06 Security information" on page 6-1.

**RESTORE DEFAULT SETTINGS**

Reset all menu settings that you have changed to the default settings set by Vertu at the manufacturing facility.



*Entries in your phone book, security codes and levels, earpiece volume and call timers and counters remain unchanged.*

To restore default settings:

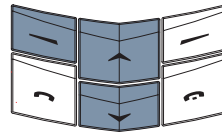
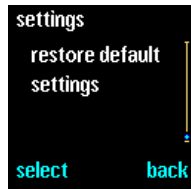

- > From the stand-by display, press **menu**.
- > Scroll to **settings**.
- > Press **select**.
- > Scroll to **restore default settings**.
- > Press **select**.
- > Key in the security code.
- > Press **ok**. A confirmation message appears.

## CALL DIVERT

(Network service)

The **call divert** feature redirects your incoming calls to another number, for example your voice mailbox number.

 *When a call is diverted your Vertu phone does not give any indication of an incoming call.*

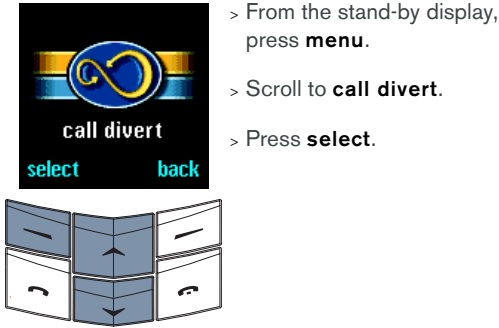

To access the **call divert** menu:



- > From the stand-by display, press **menu**.
- > Scroll to **call divert**.
- > Press **select**.

The following options are available:

**divert all voice calls**      Divert all voice calls.

 *The  icon appears on the stand-by display below the signal strength indicator **divert all voice calls** is active.*

- divert if busy**      Divert voice calls when you are already in a call.
- divert if not answered**      Divert voice calls when you do not answer an incoming call.
- divert if out of reach**      Divert voice calls when your Vertu phone is switched off or you do not have adequate signal strength.
- divert if not available**      Divert voice calls when your number is busy, you do not answer a call, your Vertu phone is switched off or you do not have adequate signal strength.
- divert all fax calls**      Divert all fax calls.
- divert all data calls**      Divert all data calls.
- cancel all diverts**      Cancel all diverted options you have set.

To check the status of call divert options:

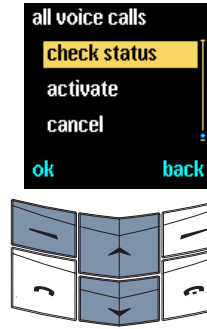

- > From the stand-by display, press **menu**.
- > Scroll to **call divert**.
- > Press **select**.
- > Scroll to the required option.
- > Press **select**.
- > Scroll to **check status**.
- > Press **ok**. A progress indicator appears, followed by an information note indicating if the option is active or not.

To activate call divert options:

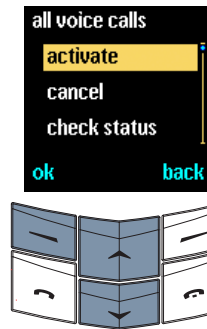

- > From the stand-by display, press **menu**.
- > Scroll to **call divert**.
- > Press **select**.
- > Scroll to the required option.
- > Press **select**. **activate** is highlighted.
- > Press **ok**. **to voice mailbox** is highlighted.

To divert calls to your voice mailbox number:

- > Press **ok**.

To divert calls to a different number:

- > Scroll to **to other number**.
- > Press **ok**.
- > Key in the number.
- > Press **ok**. A confirmation message appears.

To set the delay for the **divert if not available** option:

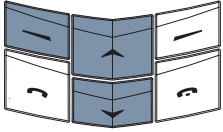

- > From the stand-by display, press **menu**.
- > Scroll to **call divert**.
- > Press **select**.
- > Scroll to **divert if not available**.
- > Press **select**.
- > Scroll to **set delay**.
- > Press **ok**. Scroll to one of the options, from 5 seconds to 30 seconds.
- > Press **ok**. A confirmation message appears.

To cancel call divert options:

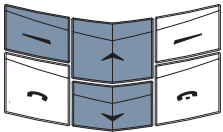
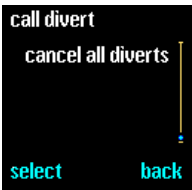

- > From the stand-by display, press **menu**.
- > Scroll to **call divert**.
- > Press **select**.
- To cancel a single call divert option:
- > Scroll to the required option.
- > Press **select**.
- > Scroll to **cancel**.
- > Press **ok**. A confirmation message appears.

To cancel all call divert options:

- > Scroll to **cancel all divers**.
- > Press **select**. A confirmation message appears.

## AGENDA

The agenda feature acts as a personal organiser that allows you to view a calendar and set reminders for forthcoming events or dates.

To access the **agenda** feature:

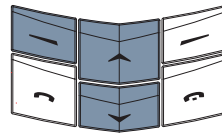

- > From the stand-by display, press **menu**.
- > Scroll to **agenda**.
- > Press **select**. Today's date is highlighted.
- > Use the **scroll** keys to move the highlight to other dates.

You can easily identify the selected date, today's date and any dates which have agenda notes. The selected date is highlighted, and the highlight moves as you press the **scroll** keys. Today's date always has a frame surrounding it, whatever date is selected. Dates which have agenda notes are underlined.

## SETTING UP YOUR AGENDA

To use the agenda feature, the date and time must be set. If your Vertu phone was purchased at a Vertu store, the time and date may already be set up for you. If not, and you did not set the time and date the first time you switched on your Vertu phone, follow the procedure below.

To access the **settings** menu for your agenda:

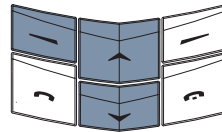
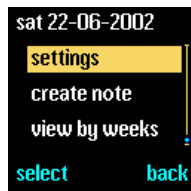

- > From the stand-by display, press **menu**.
- > Scroll to **agenda**.
- > Press **select**.
- > Press **options**.
- > Scroll to **settings**.
- > Press **select**.

Several options are available and are accessed as follows:

#### set the date

- Set the current date.
- > When you access the **settings** submenu, **set the date** is highlighted.
- > Press **select**.
- > Key in the date.
- > Use the **SCROLL** keys to toggle between the figures.
- > Press **ok**. A confirmation message appears.

#### set the time

- Set the current time.
- > Scroll to **set the time** and change as required. For more information see "Changing the time" on page 3-24.

#### date format

- Set how dates appear, for example when you view agenda notes and text messages.
- > Scroll to **date format**.
- > Press **select**.
- > Scroll to one of the following: **dd mm yyyy**, **mm dd yyyy** or **yyyy mm dd**.
- > Press **select**.
- > Scroll to the desired date separator.
- > Press **select**. A confirmation message appears.

#### time format

- Set the time format to use the 12- or 24-hour clock.
- > Scroll to **time format** and change as required. For more information see "Setting the time format" on page 3-25.

#### week starts on

- Set the first day of the week on the agenda display.
- > Scroll to **week starts on**.
- > Press **select**.
- > Scroll to one of the following: **monday**, **sunday** or **saturday**.
- > Press **select**. A confirmation message appears.

#### auto erase

- Set how long agenda notes remain in your Vertu phone's memory before being erased.
- > Scroll to **auto erase**.
- > Press **select**.
- > Scroll to one of the following: **never**, **after 1 month**, **after 3 months** or **after 6 months**.
- > Press **select**. A confirmation message appears.



*Repeated notes and anniversary notes are not deleted when **auto erase** is active.*

## AGENDA OPTIONS

In your agenda you can create new notes, set up how your agenda appears on the display and move easily to any date.

To access the **agenda** feature:



- > From the stand-by display, press **menu**.
- > Scroll to **agenda**.
- > Press **select**.
- > Press **options**. **view day notes** is highlighted.

Several options are available and are accessed as follows:

- view day notes** View agenda notes for the selected day.
- > Press **select** to view the first agenda note.
  - > Press the lower **scroll** key to view subsequent notes.



**view day notes** is only visible if there are notes created for that day.

- create note** Create agenda notes for the selected day.
- For more information see "Creating agenda notes" on page 3-33.

- view by weeks** Highlight weeks in your agenda instead of days.
- > Scroll to **view by weeks**.
  - > Press **select**.
  - > Use the **scroll** keys to move to different weeks.



Use the **view by weeks** option when you want to scroll quickly through your agenda to see which dates have agenda notes attached.

## go to date

Go to a specific date and view any notes for that date.

- > Scroll to **go to date**.
- > Press **select**.
- > Key in the date you want to go to.
- > Press **ok**.

The selected date appears with any notes for that date.

## settings

Set up how the agenda appears on the display.

- > Scroll to **settings**.
- > Press **select**.

For more information see "Setting up your agenda" on page 3-31.

## CREATING AGENDA NOTES

You can use the **agenda** feature to create reminders for meetings, birthdays, annual events and reminders of calls you have to make. You can also set an audible alert for each reminder.

## REMINDER AGENDA NOTE

To create a reminder agenda note, for example to remind you of an appointment or meeting:



- > From the stand-by display, press **menu**.
- > Scroll to **agenda**.
- > Press **select**.

Either

- > Scroll to the date for the agenda note.

or

- > Press **options**.
- > Scroll to **go to date**.
- > Press **select**.
- > Key in the date for the agenda note.
- > Press **ok**.

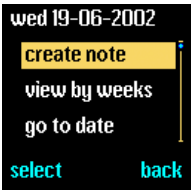

> Press **options**. **create note** is highlighted.

> Press **select**. **reminder** is highlighted.

> Press **select**.

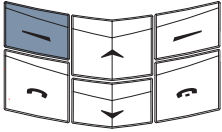

> Key in a title for the agenda note.

> Press **ok**.

> Key in the time for the agenda note.

> Press **ok**.

If the clock is set to the 12-hour format, the following screen also appears:



> Scroll to **am** or **pm**.

> Press **select**. A confirmation message appears.

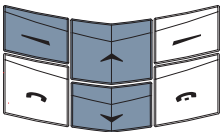

If you want an audible alert to sound before the agenda note time:



Either

> Scroll to one of the following: **5 min before**, **10 min before**, **15 min before** or **30 min before**.

> Press **select**. A confirmation message appears.

or

> Scroll to **other**.

> Press **select**.

> Key in the time for the audible alert to sound.

> Press **ok**. A confirmation message appears.

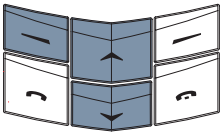

If you want an audible alert to sound at the agenda note time:

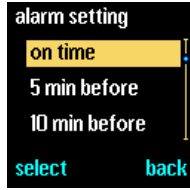

> Scroll to **on time**.

> Press **select**. A confirmation message appears.

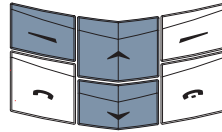

If you do not want an audible alert to sound for the agenda note:

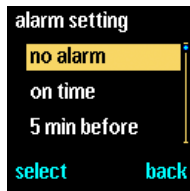

> Scroll to **no alarm**.

> Press **select**. A confirmation message appears.

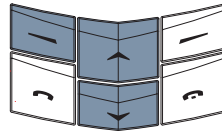

#### CALL AGENDA NOTE

To create an agenda note to remind you of a call you are due to make at a specific time:

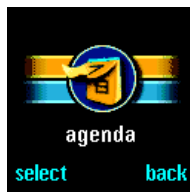

> From the stand-by display, press **menu**.

> Scroll to **agenda**.

> Press **select**.

Either

> Scroll to the date for the agenda note.

or

> Press **options**.

> Scroll to **go to date**.

> Press **select**.

> Key in the date for the agenda note.

> Press **ok**.

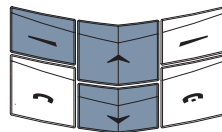



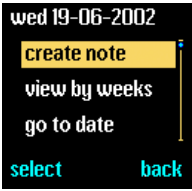

- > Press **options**. **create note** is highlighted.
- > Press **select**.
- > Scroll to **call**.
- > Press **select**.

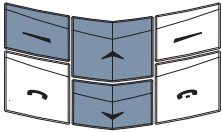

- Either
- > Key in the number you want to dial.
  - or
  - > Press **search**.
  - > Scroll to a name in your directory.
  - > Press **ok**.
  - > If the name in your directory has multiple numbers associated with it, scroll to the desired number and press **ok**.
  - > Key in the time you want to make the call.
  - > Press **ok**.

If the clock is set to the 12-hour format, the following screen also appears:



- > Scroll to **am** or **pm**.
- > Press **select**. A confirmation message appears.

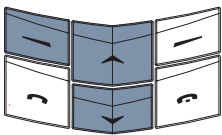

If you want an audible alert to sound before the call time:

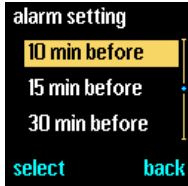

- either
- > Scroll to one of the following: **5 min before**, **10 min before**, **15 min before** or **30 min before**.
  - > Press **select**. A confirmation message appears.
- or
- > Scroll to **other**.
  - > Press **select**.
  - > Key in the time for the audible alert to sound.
  - > Press **ok**. A confirmation message appears.

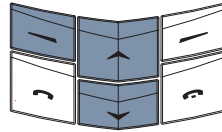

If you want an audible alert to sound at the call time:

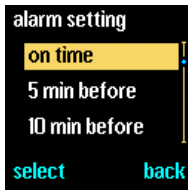

- > Scroll to **on time**.
- > Press **select**. A confirmation message appears.

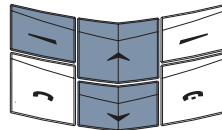

If you do not want an audible alert to sound for the call:

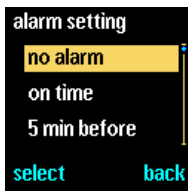

- > Scroll to **no alarm**.
- > Press **select**. A confirmation message appears.

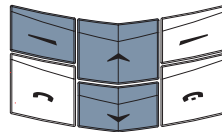

### ANNIVERSARY AGENDA NOTE

To create an agenda note to remind you of an annual event, for example an anniversary or a birthday:



- > From the stand-by display, press **menu**.
- > Scroll to **agenda**.
- > Press **select**.

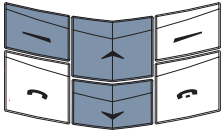

- > Press **options**.
- > Scroll to **create note**.
- > Press **select**.
- > Scroll to **anniversary**.

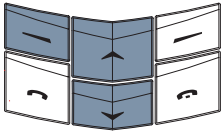

- > Press **select**.
- Either
- > Key in a title for the agenda note.
- or
- > Press **search**.
- > Scroll to a name in your directory.
- > Press **ok**.
- > Key in any additional text, if required.
- > Press **ok**.
- > Key in the date for the agenda note.
- > Press **ok**.

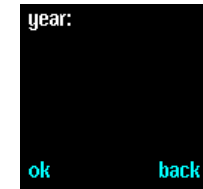

- Either
- > Key in the year of the event, for example a year of birth for a birthday or the year of a wedding for a wedding anniversary.
- or
- > Press **ok** without keying in a year, for example when the reminder is for an annual subscription which becomes due.

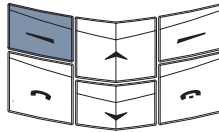

 *When creating anniversary agenda notes, you cannot enter a year which makes the first occurrence of the event some time in the future.*

If you want an alert to remind you before the day of the agenda note:

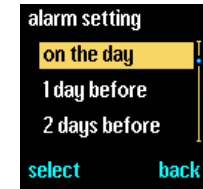

- Either
- > Scroll to one of the following: **1 day before**, **2 days before**, **3 days before** or **week before**.
- > Press **select**.
- or
- > Scroll to **other**.
- > Press **select**.
- > Key in the date for the audible alert to sound.
- > Press **ok**. A confirmation message appears.

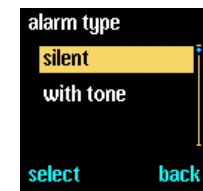
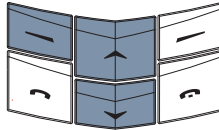

- Set whether an audible alert sounds with the reminder:
- > Scroll to **silent** or **with tone**.
- > Press **select**. A confirmation message appears.

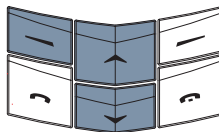

If you want an alert to remind you on the day of the agenda note:



> Scroll to **on the day**.

> Press **select**.

or

> Scroll to **other**.

> Press **select**.

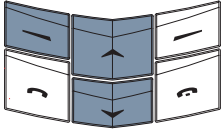

> Key in the day for the alert.

> Press **ok**.

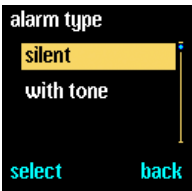

Set whether an audible alert sounds with the reminder:

> Scroll to **silent** or **with tone**.

> Press **select**. A confirmation message appears.

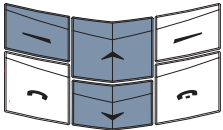

If you do not want an audible alert to sound for the call:

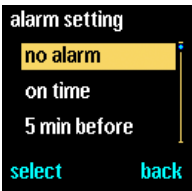

> Scroll to **no alarm**.

> Press **select**. A confirmation message appears.

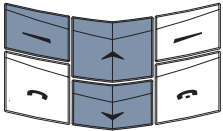

After you create an anniversary agenda note, your Vertu phone displays the date and title of the agenda note. If you have keyed in a year, the number of years appears beside the agenda note title. Press **back** to return to the agenda display.

#### AGENDA NOTE OPTIONS

Once you have created agenda notes you can view, edit, copy and move notes in your agenda.

To access an agenda note:

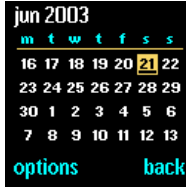

> From the stand-by display, press **menu**.

> Scroll to **agenda**.

> Press **select**. Today's date is highlighted.

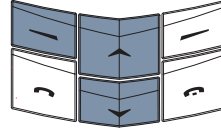

Either

> Use the **scroll** keys to move the highlight to the required date if necessary.

> Press **options**. **view day notes** is highlighted.

> Press **select**.

> If the selected day has more than one agenda note, scroll to the required note.

or

> Press **options**.

> Scroll to **go to date**.

> Key in the required date.

> Press **ok**. The highlight jumps to the selected date.

> Press **options**. **view day notes** is highlighted.

> Press **select**.

> If the selected day has more than one agenda note, scroll to the required note.

Several options are available and are accessed as follows:

#### **create note**

Create another agenda note for the selected day.

> Press **options**.

> Scroll to **create note**.

> Press **select**.

#### **erase**

Erase the agenda note for the selected day from the agenda.

> Press **options**.

> Scroll to **erase**.

> Press **select**.

- edit** Change the details of the agenda note.
- > Press **options**.
  - > Scroll to **edit**.
  - > Press **select**.
- Edit the agenda note as required.
- move** Move the agenda note to another date and erase it from the selected date.
- > Press **options**.
  - > Scroll to **move**.
  - > Press **select**.
  - > Key in the new date for the agenda note.
  - > Press **ok**.
  - > If the agenda note is an anniversary note, set a date and an alarm type as required.
  - > If the agenda note is a call or reminder note, set the new date, time and alarm setting as required.
- repeat** Repeat a call or reminder agenda note at selected intervals.
- > Press **options**.
  - > Scroll to **repeat**.
  - > Press **select**.
  - > Scroll to one of the following: **every day**, **every week**, **every 2 weeks** or **every year**.
  - > Press **select**. A confirmation message appears.

- To cancel a repeat:
- > Press **options**.
  - > Scroll to **repeat**.
  - > Press **select**.
  - > Scroll to **repeat off**.
  - > Press **select**. A confirmation message appears.



*Repeated notes and anniversary notes are not deleted when **auto erase** is active.*

**view by weeks**

- Highlight weeks in your agenda instead of days.
- > Scroll to **view by weeks**.
  - > Press **select**.
  - > Use the **scroll** keys to move to different weeks.



*Use the **view by weeks** option when you want to scroll quickly through your agenda to see which dates have agenda notes attached.*

**go to date**

- Go to a specific date and view any notes for that date.
- > Scroll to **go to date**.
  - > Press **select**.
  - > Key in the date you want to go to.
  - > Press **ok**.
- The selected date appears with any notes for that date.



*The  icon appears on the display when viewing a repeated agenda note.*

**send note**

Send the agenda note to another phone.

- > Press **options**.
- > Scroll to **send note**.
- > Press **select**.

To send the agenda note to another Vertu phone's agenda:

- > Scroll to **as agenda note**.
- > Press **select**.

Either

- > Key in the recipient's number.
- > Press **ok**. A confirmation message appears.
- or
- > Press **search**.
- > Scroll to a name in your directory.
- > Press **ok**.
- > If the name in your directory has multiple numbers associated with it, scroll to the desired number and press **ok**.
- > Press **ok**. A confirmation message appears.
- > Press **search**.
- > Scroll to a name in your directory.
- > Press **ok**. The default number for the recipient appears.
- > Press **ok**. A confirmation message appears.

To send the agenda note to another phone as a text message:

- > Scroll to **as text**.
- > Press **select**.

Either

- > Key in the recipient's number.
  - > Press **ok**. A confirmation message appears.
  - or
  - > Press **search**.
  - > Scroll to a name in your directory.
  - > Press **ok**.
  - > If the name in your directory has multiple numbers associated with it, scroll to the desired number and press **ok**.
  - > Press **ok**. A confirmation message appears.
- Copy the agenda note to another date without removing the note from the original date.
- > Press **options**.
  - > Scroll to **copy**.
  - > Press **select**.
  - > Key in the new date for the agenda note.
  - > Press **ok**.
  - > If the agenda note is an anniversary note, set a date and an alarm type as required.
  - > If the agenda note is a call or reminder note, set the new date, time and alarm setting as required.

**copy**

**settings**

Set up how the agenda appears on the display.

> Scroll to **settings**.

> Press **select**.

For more information see “Setting up your agenda” on page 3-31.

For more information on editing agenda notes see “Creating agenda notes” on page 3-33.



*You can move to a future date in the calendar display quickly. For example if today is the 9th, key in “3”. The date changes to the third day of the following month.*

**AGENDA NOTE ALARMS**

At the specified time, an audible alert sounds and the alarm time and display lights flash, unless you have switched off warning tones.

To stop the alarm and view the note:

> Press **view**.

To stop the alarm without viewing the note:

> Press **back**.

When the note alarm is a call note, to call the displayed number:

> Press the **SEND** key.

**SIM SERVICES**

(Network service)

The **SIM services** feature may offer additional features or facilities such as online banking or sports information. The name may be different, and the feature's availability is at the discretion of your service provider.

For more information contact your service provider.

## 04 ADVANCED CALL FUNCTIONS

Your Vertu phone contains advanced functionality to use while making calls.

### SPEED DIALLING

Speed dialling allows you to dial a number quickly and easily by pressing and holding a single NUMBER key between 2 and 9.

 The 1 key is already assigned as the speed dialling key for your voice mailbox.

### ACTIVATING SPEED DIALLING

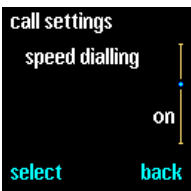

From the stand-by display, press **menu**.

Scroll to **settings**.

Press **select**.

Scroll to **call settings**.

Press **select**.

Scroll to **speed dialling**.

Press **select**. **off** is highlighted.

To turn speed dialling on:

> Scroll to **on**.

> Press **select**. A confirmation message appears.

To turn speed dialling off:

> Press **select**. A confirmation message appears.

### ASSIGNING SPEED DIAL NUMBERS



From the stand-by display, press **directory**.

Scroll to **speed dials**.

Press **select**.

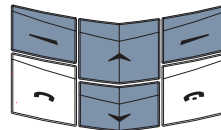
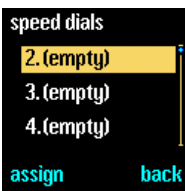
Scroll to an empty speed dial key.

Press **assign**.

Either

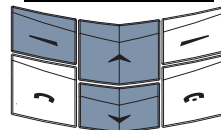
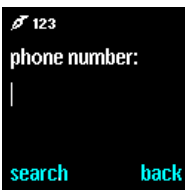
> Key in the number you want to assign.

> Press **ok**.

> Key in the name.

> Press **ok**. A confirmation message appears.

or

> Press **search** to access the list of names in your directory.

> Scroll to the desired name.

> Press **select**.

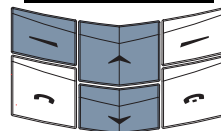

> If the name has more than one number, scroll to the number you want to assign.

> Press **select**. A confirmation message appears.



The name appears beside the speed dial key as shown.

VIEWING THE SPEED DIAL LIST

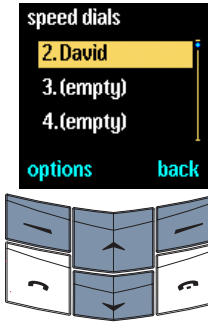

- > From the stand-by display, press **directory**.
- > Scroll to **speed dials**.
- > Press **select**.
- > Scroll through the list to see the names assigned to the speed dial keys.

CALLING WITH SPEED DIALLING

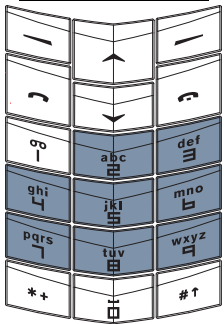
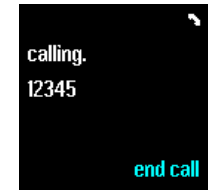

- Either
- > From the stand-by display, press and hold the desired speed dial key (in this example 2) to dial the number assigned to it.
- or
- > Press **directory**.
- > Scroll to **speed dials**.
- > Press **select**.
- > Scroll to the desired name.
- > Press the **SEND** key.

 You can also press the speed dial key followed by the send key to make a call.

SPEED DIAL OPTIONS

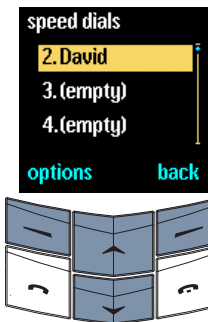

- > From the stand-by display, press **directory**.
- > Scroll to **speed dials**.
- > Press **select**. The list of speed dial keys appears.
- > Scroll to the desired name.
- > Press **options**.

Several options are available and are accessed as follows:

**view number**

View the number assigned to the speed dial key.  
**view number** appears after you access the options submenu.

- > Press **select**. The speed dial key and number appears.

**change**

Change the name and number assigned to the speed dial key.

- > Scroll to **change**.

- > Press **select**.

Either

- > Key in the number.
- > Press **ok**.
- > Key in a name.
- > Press **ok**. A confirmation message appears. The name and number replace the previous entry assigned to the speed dial key and the entry is added to your directory.

or

- > Press **search** to access the list of names in your directory.
- > Scroll to the desired name.
- > Press **select**.

- > If the name has more than one number, scroll to the number you want to assign.

- > Press **select**. A confirmation message appears. The name and number replace the previous entry assigned to the speed dial key.

**undo speed dial**

Remove the name and number assigned to the speed dial key.

- > Scroll to **undo speed dial**.
- > Press **select**.
- > Press **ok** to confirm. A confirmation message appears. The speed dial key is now empty.



## SPEAKER PHONE

The speaker phone uses the internal speaker in your Vertu phone to allow you to have a hands-free phone call or allow people around you to participate in conversation.

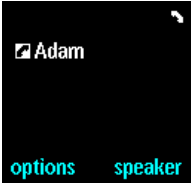

To use the speaker phone while in a call:



> Press **speaker** to activate the speaker phone. A confirmation message appears.

You no longer need to hold your Vertu phone in the normal speaking position.

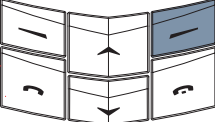
> Continue your conversation.





To deactivate the speaker phone:

> Press **personal**. A confirmation message appears.

> Return your Vertu phone to the normal speaking position.

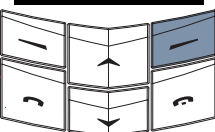
> Continue your conversation.



 *The call options remain available when using the speaker phone.*

## CALL WAITING

(Network service)

When call waiting is active and you have a call in progress, your Vertu phone will notify you of an incoming call.

### ACTIVATING CALL WAITING



> From the stand-by display, press **menu**.

> Scroll to **settings**.

> Press **select**.

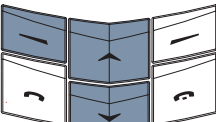
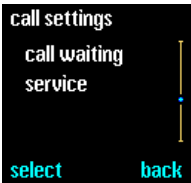



> Scroll to **call settings**.

> Press **select**.

> Scroll to **call waiting service**.

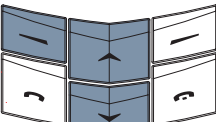
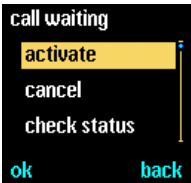
> Press **select**. **activate** is highlighted.



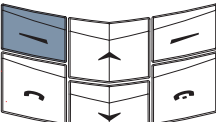

> Press **ok**. A confirmation message appears.

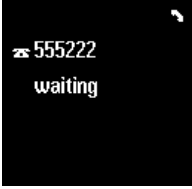

### USING CALL WAITING

When you have a call in progress and you receive an incoming call, an audible alert can be heard.



At the same time as the audible alert sounds, the display indicates that another call is waiting.

If you have stored the incoming caller's number in your directory, the person's name may appear on the display (network dependent).

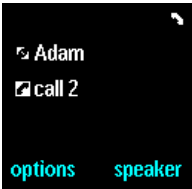

To answer the incoming call:

- > Press the **SEND** key. The person you were speaking to is put on hold.

To reject the incoming call:

- > Press **options**.
- > Scroll to **reject**.
- > Press **select**.

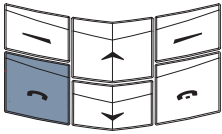

If you have set your Vertu phone to **divert if busy** and you reject an incoming call, the call is diverted to the number you have set. For more information refer to "Call divert" on page 3-30.

### SWAPPING BETWEEN CALLS

To switch between the active call and the held call:

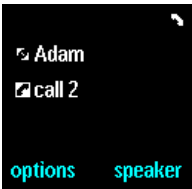

- > Press the **SEND** key. A confirmation message appears. The person on hold becomes the active call, and the other person is put on hold.

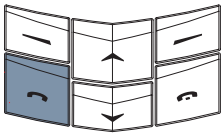

The icon  indicates the active call.

### ENDING ONE OF THE CALLS

To end one of the calls:

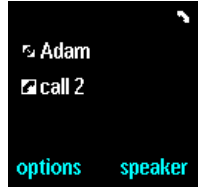

- > Ensure the call you want to end is the active call. In this example Adam's call is on hold, the second call is active.

Either

- > Press the **END** key. A confirmation message appears.

or

- > Press **options**.
- > Scroll to **end active call**.
- > Press **select**. A confirmation message appears.

The remaining call becomes active.

### ENDING BOTH CALLS

To end both calls at the same time:

- > Press **options**.
- > Scroll to **end all calls**.
- > Press **select**. A confirmation message appears.

## IN CALL FUNCTIONS

While you are in a call, several functions are available from the **options** submenu:

- new call**                      Make a new call while you have a call in progress.
  
- end all calls**                Disconnect all calls and return to stand-by.
  
- directory**                    Access the directory. For more information see "Chapter 02 The directory".
  
- menu**                         Access your Vertu phone's menus. For more information see "Chapter 03 The menus".
  
- mute or unmute**            Mute or unmute your Vertu phone's microphone. When you mute a call you can hear the other person you are in a call with, but the person cannot hear you.
  
- hold or unhold**             Put a call on hold and unhold a held call. When you hold a call you cannot hear the person you are in a call with and the person cannot hear you.
  
- swap**                         Switch between the active call and the held call.
  
- transfer**                     Connect the active call directly to the held call and disconnect yourself from both calls.
  
- conference**                 Join several calls together into one conversation.
  
- end active call**             Disconnect the active call and make the held call active.

## CALL HOLDING

(Network service)

Call holding allows you to put a call on hold. The call remains active, but no communication can take place until you unhold the call.

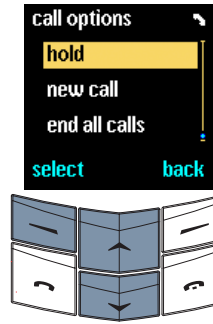

- To put a call on hold:
  - > Press **options**.
  - > Scroll to **hold**.
  - > Press **select**. A confirmation message appears.
  
- To unhold the call:
  - > Press **options**.
  - > Scroll to **unhold**.
  - > Press **select**. A confirmation message appears.

 The icon  indicates the held call.

## MUTING A CALL

When you mute a call you can hear the person you are in a call with, but the person cannot hear you.

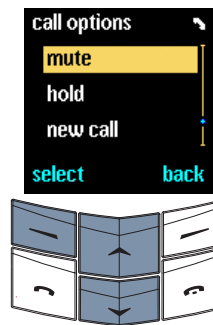

- To put a call on mute:
  - > Press **options**.
  - > Scroll to **mute**.
  - > Press **select**. A confirmation message appears.
  
- To unmute the call:
  - > Press **options**.
  - > Scroll to **unmute**.
  - > Press **select**. A confirmation message appears.

### MAKING MULTIPLE CALLS

You can make a call when you already have a call in progress.

To make another call while in a call:

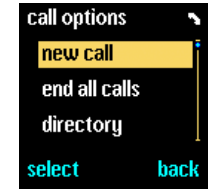

- > Press **options**. **new call** is highlighted.
- > Press **select**.

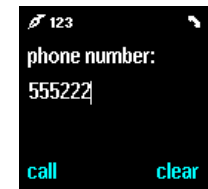
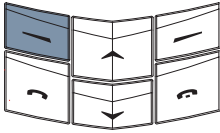

- Either
- > Key in a number.
  - > Press **call** or the **SEND** key. The active call is put on hold while the new call attempts to connect.

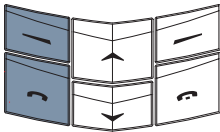

- or
- > Press **search** to access the list of names in your directory.
  - > Scroll to the desired name.
  - > Press **select**.
  - > If the name has more than one number, scroll to the number you want to call.
  - > Press **call** or the **SEND** key to call the selected number. The active call is put on hold while the new call attempts to connect.

### SWAPPING BETWEEN CALLS

To switch between the active call and the held call:

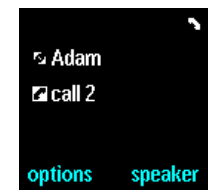

- > Press the **SEND** key. A confirmation message appears. The person on hold becomes the active call, and the other person is put on hold.

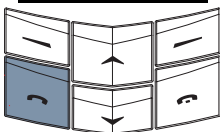

The icon  indicates the active call.

### ENDING ONE OF THE CALLS

To end one of the calls:

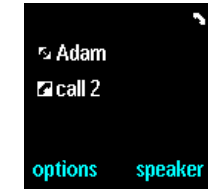

- > Ensure the call you want to end is the active call. In this example Adam's call is on hold, the second call is active.

Either

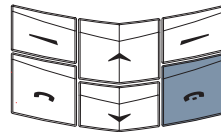

- > Press the **END** key. A confirmation message appears.
- or
- > Press **options**.
- > Scroll to **end active call**.
- > Press **select**. A confirmation message appears.

The remaining call becomes active.

### ENDING BOTH CALLS

To end both calls at the same time:

- > Press **options**.
- > Scroll to **end all calls**.
- > Press **select**. A confirmation message appears.

### TRANSFERRING CALLS

(Network service)

The transfer function connects the active call to the held call so they can communicate directly with each other. When you transfer a call you are disconnected from both calls and your Vertu phone returns to stand-by.

To transfer a call:

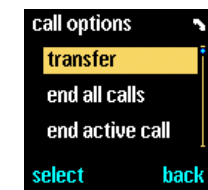

- > Press **options**.
- > Scroll to **transfer**.
- > Press **select**. A confirmation message appears. The two calls are connected to each other, and you are disconnected from both calls.

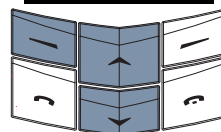

CONFERENCE CALLS

(Network service)

The conference call function can connect up to six calls, allowing each person to participate in a single conversation.

To set up a conference call:

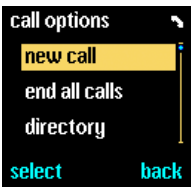

call options

new call

end all calls

directory

select back

- > Call the first participant.
- > Press **options**. **new call** is highlighted.
- > Press **select**.

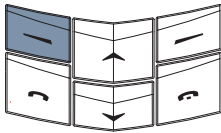
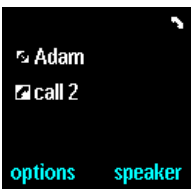



Adam

call 2

options speaker

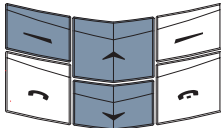
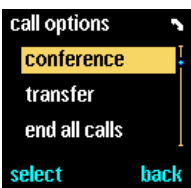
- > Call the next participant.
- > Press **options**.
- > Scroll to **conference**.

call options

conference

transfer

end all calls

select back

- > Press **select**. A confirmation message appears.

To involve other participants, repeat the previous six steps each time you want to add a new participant to the conference call.

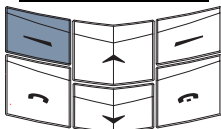

To have a private conversation with one of the participants:

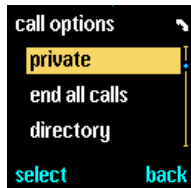

call options

private

end all calls

directory

select back

- > Press **options**.
- > Scroll to **private**.
- > Press **select**.
- > Scroll to the desired participant.
- > Press **ok**. A confirmation message appears. The other participants cannot hear your conversation with the selected person.

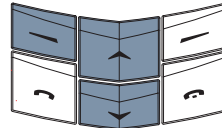

To end the private conversation and return to the conference call:

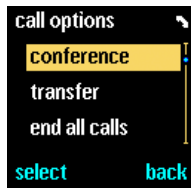

call options

conference

transfer

end all calls

select back

- > Press **options**.
- > Scroll to **conference**.
- > Press **select**. A confirmation message appears.

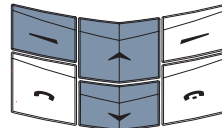

To end the conference call and disconnect all participants:

- > Press the **END** key.

## PAUSE AND WAIT COMMANDS

Pause and wait commands allow you to automate NUMBER key presses after a call has been connected, for example when navigating menus in an automated switchboard or accessing an answer phone system. You can include pause and wait commands in a number that you want to store in your directory.

 *Numbers that include pause and wait commands can only be stored to the phone memory, not to the SIM card memory.*

The following number contains both pause and wait commands:

+44167744w234410p1234

The first part of the number, “+44167744”, is a phone number, for example the number of a bank.

The “w” is the “wait” command that waits until the SEND key is pressed before sending the second number, “234410”, for example the account number.

The “p” is the “pause” command that inserts a delay of two seconds before sending the final number “1234”, for example the PIN number for the account.

You can use as many pause commands and wait commands in a number as you require, providing the number does not exceed the maximum number of characters allowed in the phone memory.

If you need to include a pause that is longer than two seconds, you can insert several pauses, one after the other.

 *If you use pause and wait commands to access an automated service that requires authorisation, we recommend you make use of the security features on your Vertu phone. For more information refer to “Changing the security code” on page 6-3.*

## SETTING UP PAUSE AND WAIT COMMANDS

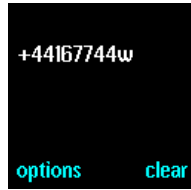

- > From the stand-by display, key in the phone number, for example “+44167744”.
- > Press the \* + key four times to insert a “w”.

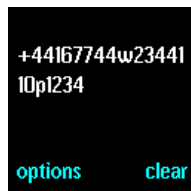

- > Key in the second part of the number, for example account number “2344110”.
- > Press the \* + key three times to insert a “p”.

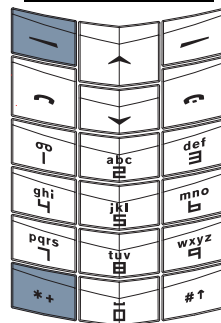

- > Key in the next part of the number, for example PIN number, “1234”.
- > Press **options**. **save** is highlighted.
- > Press **select**.

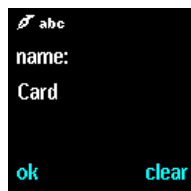

- > Key in an appropriate name, for example “Card”.
- > Press **ok**. A confirmation message appears if your directory is set to use the phone memory.

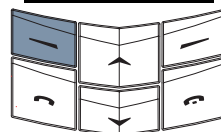

- > If your Vertu phone is set to use the SIM card memory you are prompted to save to another memory.
- > Press **yes**. A confirmation message appears.

USING PAUSE AND WAIT COMMANDS



- > From the stand-by display, press a `SCROLL` key.
- > Scroll to the required name.
- > Press the `SEND` key.

Your Vertu phone dials the first part of the number, up to the "w".

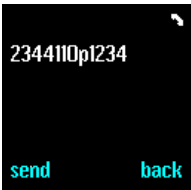
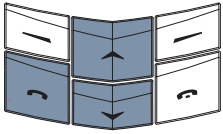

- > Press **send** after the call has connected and the automated service prompts you for your account number.

Your Vertu phone sends the account number and pauses for two seconds.

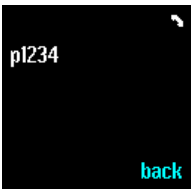
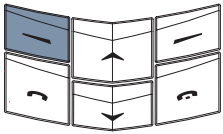

After the two second pause, your Vertu phone sends the PIN code.

## O5 ACCESSORIES

This section shows how to use accessories with your Vertu phone:

- > Headset
- > Charger and battery
- > Data cable (available separately)



**Caution. Keep all parts out of reach from small children.**

**Use only batteries, chargers and accessories approved by Vertu for use with this particular phone model. The use of any other types may invalidate any approval or warranty applying to the phone and may be dangerous.**

**When you disconnect an accessory cable from your Vertu phone, hold and pull the connector at the end of the cable, not the cable itself.**

To optimise the performance and lifetime of your accessories, and protect your warranty coverage, observe the following handling and usage precautions:

- > *Keep dry. Precipitation, humidity and all types of liquids or moisture can contain minerals that will corrode electronic circuits.*
- > *Do not use or store in dirty or dusty areas.*
- > *Do not attempt to open.*
- > *Do not drop, knock or shake. Rough handling can break fine mechanics.*
- > *Do not store in hot areas. High temperatures can shorten the life of electronic devices and damage batteries.*
- > *Do not store in cold areas.*
- > *Do not use harsh chemicals, cleaning solvents or strong detergents to clean.*
- > *Do not paint.*

For more information about the availability of accessories approved for use with your Vertu phone, contact Vertu Concierge.

## HEADSET

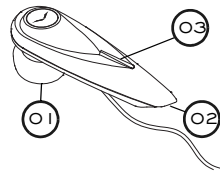

- 01 earpiece
- 02 microphone
- 03 SEND/END button

To connect the headset to your Vertu phone:

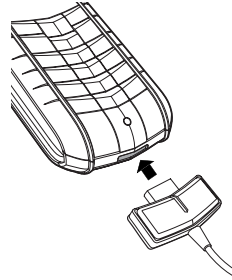

- > Insert the headset connector into the bottom of your Vertu phone as shown. Ensure the connector is correctly oriented. (Your headset connector may be slightly different to the one shown.)

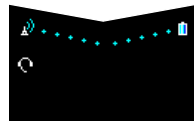

The headset icon appears below the signal strength indicator.



- > Place the earpiece in your ear.
- > Position the microphone (the pointed end) as shown.
- > Use the VOLUME key on your Vertu phone to adjust to a comfortable listening level.

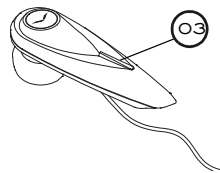

- > Press the SEND/END button (03) to answer an incoming call.
- > Press the SEND/END button to end a call.



When the headset is connected, you can configure your Vertu phone to answer calls automatically. Refer to "Profiles" on page 3-20 for more information.



## CHARGER

The charger recharges your Vertu phone battery quickly and safely by means of a powered AC outlet.

The charger supplied with your Vertu phone should be appropriate for your region. However, you should always check that electrical rating of the AC outlet is appropriate for the charger before you attempt to plug it in.



**Caution. Never attempt to use a charger if it has been damaged. Contact Vertu Concierge to obtain a replacement.**

### ATTACHING THE CHARGER CABLE

If your charger has a removable cable, you have to attach it to the charger before you plug it in:

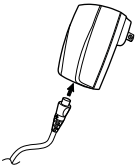

- > Attach the charger cable by inserting it into the charger body.

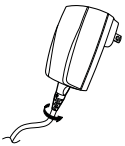

- > Turn the cable a quarter of a turn, in the direction shown by the arrow, to lock into place.
- > Reverse the procedure to detach the cable.

### ATTACHING THE CABLE TO PHONE CONNECTOR

If your charger has a fixed cable with a barrel style plug, you have to attach the phone connector adaptor:

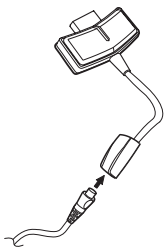

- > Attach the charger cable by inserting it into the adaptor body.

## CHARGING YOUR BATTERY

The battery for your Vertu phone is rechargeable and requires charging at regular intervals.



**Caution. Only use the approved charger and battery designed specifically for your Vertu phone.**

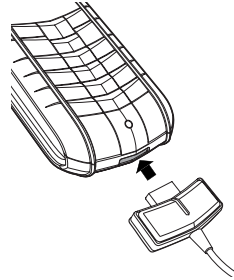

- > Insert the charger connector into the bottom of your Vertu phone as shown. Ensure the connector is correctly oriented. (Your charger connector may be slightly different to the one shown.)

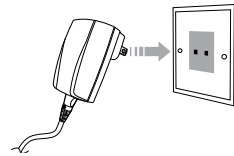

- > Connect the charger body to a powered AC outlet.
- > After approximately 10 seconds the battery indicator animates, and a confirmation message is displayed if your Vertu phone is switched on.

If the battery is fully discharged it may take a few moments before the charging indicator appears on the display.

When the battery is fully charged, the battery charge indicator stops animating and, if your Vertu phone is switched on, a confirmation message is briefly displayed.

If **not charging** is displayed or charging has failed, try the following:

- > Disconnect the charger from the AC outlet.
- > Check that the electrical rating of the AC outlet is compatible with your charger.
- > Verify that the AC outlet has power and that it is switched on. For example, in many hotel rooms, AC outlets are used for lighting and may be switched from remote locations in the room.
- > Wait for at least 10 seconds and then reconnect the charger to the AC outlet.
- > Use another nearby AC outlet that you know is providing power.
- > If charging still fails, contact Vertu Concierge for further advice.

The vibrating alert is disabled while the charger is connected to your Vertu phone.

When you want to stop charging your battery, for example when charging is complete:

- > Disconnect the charger from the AC outlet.
- > Disconnect the charger from your Vertu phone by pulling the charger connector – do not pull the charger cable.

The charger can be used in conjunction with the data cable.

## DATA CABLE



*The data cable is not supplied with your Vertu phone. It is available for purchase from all Vertu stores.*

When used in conjunction with a compatible computer, the data cable allows you to use the Vertu Data Suite software supplied on the CD-ROM to manage your phone and its data. The data cable also enables you to use your Vertu phone as a modem to transfer data, or send and receive faxes. For more information on using your Vertu phone as a modem contact your service provider.

You will need to install Vertu Data Suite in order to use your Vertu phone as a modem.

## CONNECTING THE DATA CABLE

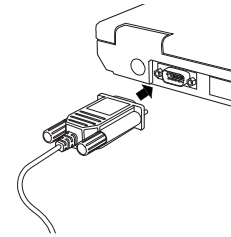

- > Connect the end of the data cable with the screws attached to the Serial (COM) port of your compatible computer, ensuring it is seated properly.

- > Tighten the screws.

- > Ensure your Vertu phone is switched on.

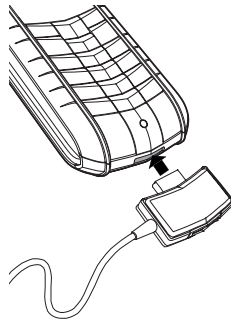

- > Insert the data cable connector into the bottom of your Vertu phone as shown. (Your data cable connector may be slightly different to the one shown.)

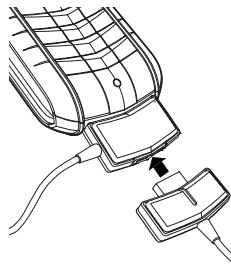

If necessary, with the data cable inserted, you can also connect the charger to your Vertu phone.

- > Plug the charger connector into the back of the data cable connector as shown.



*The headset will not operate if the headset connector is plugged into the back of the data cable connector.*

## INSTALLING VERTU DATA SUITE

Vertu Data Suite allows you to back up and restore phone data, such as the directory and agenda, using a compatible computer. You can even synchronize with widely used agenda and contact management applications such as Microsoft® Outlook®.



*After you have installed Vertu Data Suite, your computer will restart automatically. Ensure that you have closed all other applications and saved any data you want to keep before installing Vertu Data Suite.*

- > Insert your Vertu CD-ROM into the CD-ROM tray.
- > Select your desired language. After the introduction has played, the CD contents menu is displayed.
- > Click on the INSTALL NOW button in the Vertu Data Suite section to start the installation.
- > Follow the on-screen instructions to complete the installation.

## BATTERY



**Caution. Do not dispose of batteries in a fire and always dispose of a battery according to local regulations. Do not dispose of as household waste.**

**Always switch the phone off and disconnect the charger before removing the battery.**

## REMOVING THE BATTERY

- > Switch off your Vertu phone and disconnect the charger and any accessories.

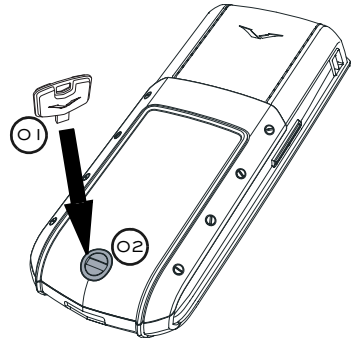

- > With the back of your Vertu phone facing you, position the back cover release key (01) very carefully into the slot of the locking screw (02). Ensure the key does not slip out of the slot.

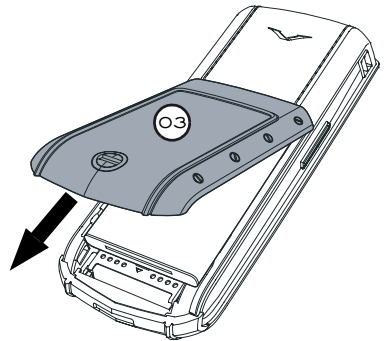

- > Turn the locking screw (02) a quarter of a turn anticlockwise, gently pivot (by no more than 45 degrees) and lift off the back cover (03) towards you as shown. If you accidentally remove the back cover while the phone is switched on, the phone will automatically switch off.

## INSTALLING THE BATTERY

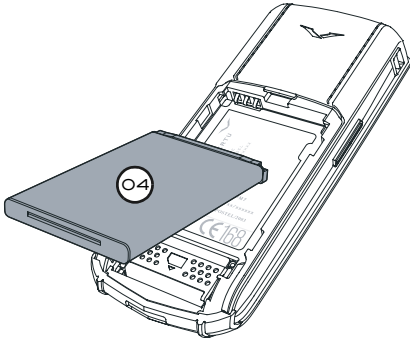

- > Gently pivot the battery (04) from the bottom and lift it upwards and outwards from your Vertu phone.

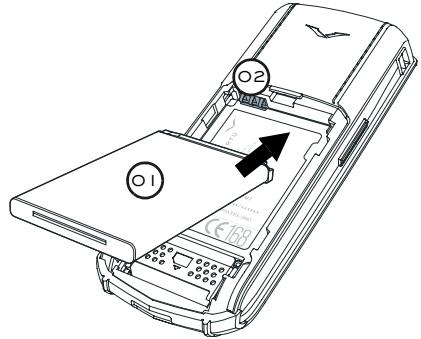

- > Insert the battery (01) top end first. Ensure that the contacts on the top end of the battery align with the contact points (02) inside the battery compartment.



- > If you do not re-insert the battery or insert another battery right away, insert the plastic placeholder (05) originally supplied with your Vertu phone before replacing the cover.



*Your Vertu phone will lose its date and time settings if the battery is removed for more than approximately two hours.*

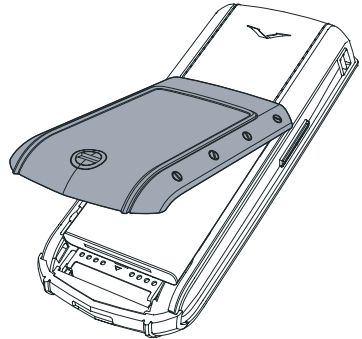

- > Pivot and slide the back cover into position until it clicks into place. The cover should close tightly using only light pressure – do not force it closed! If the cover does not close easily, remove it and check the battery is correctly inserted.

## BATTERY INFORMATION

Your Vertu phone is powered by a rechargeable battery. The full performance of a new battery is achieved only after two or three complete charge and discharge cycles. The battery can be charged and discharged hundreds of times but it will eventually wear out. If you notice that the talk and stand-by times are much shorter than normal, you may need a new battery. Contact Vertu Concierge to acquire a Vertu approved battery. Use only Vertu approved batteries and recharge your battery using only the Vertu approved chargers designed for your Vertu phone.

## CHARGING AND DISCHARGING

Unplug the charger from the AC outlet and your Vertu phone when not in use. Do not leave your Vertu phone connected to a charger. Overcharging the battery may shorten its lifetime. If left unused, a fully charged battery will lose its charge over time. Temperature extremes can affect the ability of your battery to charge.

## BATTERY CARE AND SAFETY

Use the battery only for its intended purpose. Never use any charger or battery that is damaged.

Do not short-circuit the battery. Accidental short-circuiting can occur when a metallic object such as a coin, clip, or pen causes direct connection of the positive (+) and negative (-) terminals of the battery (the metal strips on the battery.) This might happen, for example, when you carry a spare battery in your pocket, purse or bag. Short-circuiting the terminals may damage the battery and the connecting object.

Leaving the battery in hot or cold places, such as in a closed car in summer or winter conditions, will reduce the capacity and lifetime of the battery. Always try to keep the battery between 15°C and 25°C (59°F and 77°F). If your battery is very hot or extremely cold, your Vertu phone may not work temporarily, even if the battery is fully charged. Battery performance is particularly limited in temperatures well below freezing.



**Caution. Never dispose of batteries in a fire.**

**Always dispose of batteries according to local regulations. Please recycle when possible. Do not dispose of batteries as household waste.**

## 06 SECURITY INFORMATION

The security features on your Vertu phone help prevent unauthorised use of your phone and SIM card.

### SECURITY FEATURES

You can activate and change some security features yourself. These are marked "User code" in this chapter. A user code is a pre-defined number you have to key in at specified times, for example after switching on your Vertu phone.

Other security features require the assistance of your service provider to be activated. This type of security feature is marked "Network service" in this chapter. Network service security features allow you to restrict certain actions that you have specified, for example international calls.



*We recommend you activate both the security code and PIN code to help prevent the following:*

- > Unauthorised use of your Vertu phone when your SIM card is inserted.
- > Unauthorised use of your Vertu phone if a different SIM card is inserted.
- > Unauthorised use of your SIM card in another phone.



*When outgoing calls are restricted, calls may be possible to the emergency number programmed into your Vertu phone, for example 112, 911 or other official emergency number.*

Several security features are available:

security code  
(User code)

Key in the security code when another SIM card is inserted into your Vertu phone. You may also need to key in the security code at other times, depending on the security level you set. For more information see "Security code" on page 6-3.

security level  
(User code)

Specify when you will be required to key in the security code. Security level has three settings.

Select **phone** to have your Vertu phone prompt you for the security code when you switch on the phone after another SIM card has been inserted.

Select **memory** to have your Vertu phone prompt you for the security code when you try to access your directory after a different SIM card has been inserted.

Select **none** to disable the security code.

The default security level is **none**.

For more information see "Security level" on page 6-4.

PIN code  
(User code)

Key in the PIN code every time you switch on your Vertu phone.

For more information see "PIN code" on page 6-4.

|   |  |  |   |
|---|--|--|---|
| <p>call barring service<br/>(Network service)</p> | <p>Restrict incoming and outgoing calls. Call barring service has six settings.</p> <p>Select <b>outgoing calls</b> to bar all outgoing calls.</p> <p>Select <b>international calls</b> to bar all international calls made from your home country.</p> <p>Select <b>international calls except to home country</b> to bar all international calls with the exception of calls made to your home country.</p> <p>Select <b>incoming calls</b> to bar all incoming calls.</p> <p>Select <b>incoming calls when abroad</b> to bar all incoming calls when you are abroad.</p> <p>Select <b>cancel all barrings</b> to cancel all barring settings.</p> <p>For more information on the call barring service see "Call barring service" on page 6-6.</p> | <p>PIN2 code<br/>(Network service)</p>         | <p>Key in the PIN2 code before activating certain functions, for example fixed dialling. The PIN2 code is supplied with some SIM cards.</p> <p>For more information on the PIN2 code or to change the PIN2 code contact your service provider.</p>  |
| <p>fixed dialling<br/>(Network service)</p>       | <p>Restrict outgoing calls to specified phone numbers. You will need to key in the PIN2 code to save and edit numbers in the fixed dialling list.</p> <p>For more information on fixed dialling see "Fixed dialling" on page 6-7.</p>  | <p>closed user group<br/>(Network service)</p> | <p>Specify a group of people who you can call and who can call you. You can specify more than one group. Closed user group has three settings.</p> <p>Select <b>preset</b> to specify that the people included in the group, which you have agreed with the service provider, can call you and you can call them.</p> <p>Select <b>on</b> to key in the group number you want to specify.</p> <p>Select <b>off</b> to switch off the closed user group feature.</p> <p>The default closed user group is <b>off</b>.</p> <p>For more information on closed user group see "Closed user group" on page 6-7.</p> |

## SECURITY CODE

(User code)

The security code helps protect your Vertu phone from unauthorised use. You need to key in the security code before you can do the following:

- > Switch on the phone when a new SIM card is inserted.
- > Erase the contents of your directory.
- > Restore the default settings.
- > Change the security level.

The default security code is "12345".



*If you key in an incorrect security code five times in succession, your Vertu phone will not accept the correct security code for the next five minutes. Within that five minutes, your Vertu phone will show an error when you attempt to key in the security code, even if it is correct.*

## CHANGING THE SECURITY CODE

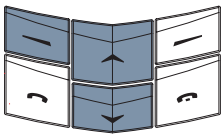
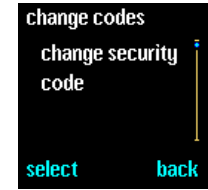

- > From the stand-by display, press **menu**.
- > Scroll to **settings**.
- > Press **select**.
- > Scroll to **security settings**.
- > Press **select**.
- > Scroll to **change access codes**.
- > Press **select**. **change security code** appears.
- > Press **select**.

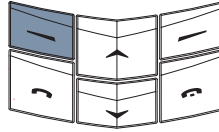
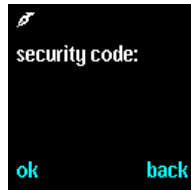

- > Key in the current security code.
- > Press **ok**.

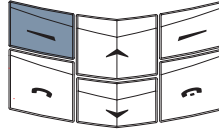
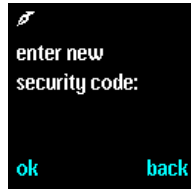

- > Key in a new five digit number of your choice.
- > Press **ok**.

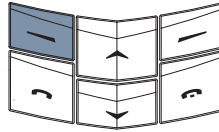

- > Key in the new number again to verify it.
  - > Press **ok**. A confirmation message appears.
- Keep the new code secret and in a safe place.



*Avoid changing your security code to a number similar to emergency numbers, such as 911 or 112.*

If you forget your security code contact Vertu Concierge for assistance.



## SECURITY LEVEL

(User code)

The security level function allows you to specify when you will be required to key in the security code.

### CHANGING THE SECURITY LEVEL



> From the stand-by display, press **menu**.

> Scroll to **settings**.

> Press **select**.

> Scroll to **security settings**.

> Press **select**.

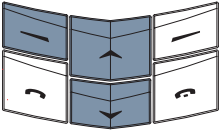
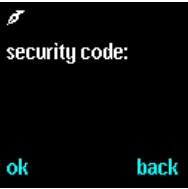

> Scroll to **security level**.

> Press **select**.

> Key in the security code.

> Press **ok**.

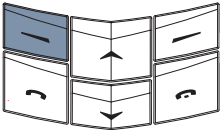
> Scroll to one of the following: **phone**, **memory** or **none**.

> Press **ok**. A confirmation message appears.

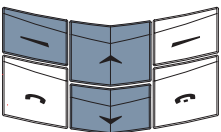

When you change the security level, the numbers in your recent dialled numbers list are erased.

## PIN CODE

(User code)

The PIN code helps protect your SIM card against unauthorised use. When the PIN code function is active, you need to key in the PIN code each time you switch on your Vertu phone. The PIN code is supplied with your SIM card or is available from your service provider.

The default setting for the PIN code function is defined by your service provider.

*The SIM card becomes blocked if you key in an incorrect PIN code three times in succession.*

*Key in the PUK code if you have blocked your SIM card.*

*PUK codes cannot be changed. If you key in an incorrect PUK code 10 times in succession your SIM card becomes permanently blocked.*

*To obtain a PUK code contact your service provider.*

ACTIVATING THE PIN CODE



> From the stand-by display, press **menu**.

> Scroll to **settings**.

> Press **select**.

> Scroll to **security settings**.

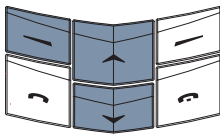
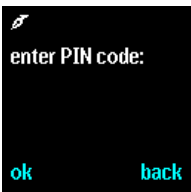

> Press **select**. **PIN code request** appears.

> Press **select**.

> Key in the PIN code.

> Press **ok**.

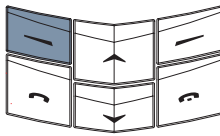

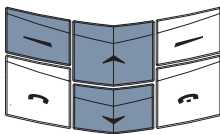

> Scroll to **on**.

> Press **ok**. A confirmation message appears.



CHANGING THE PIN CODE

 *Your PIN code must be activated before you can change it.*

To change your PIN code:

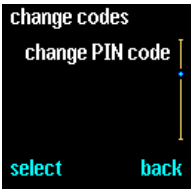

> From the stand-by display, press **menu**.

> Scroll to **settings**.

> Press **select**.

> Scroll to **security settings**.

> Press **select**.

> Scroll to **change access codes**.

> Press **select**.

> Scroll to **change PIN code**.

> Press **select**.

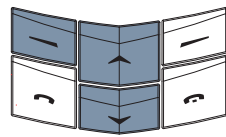
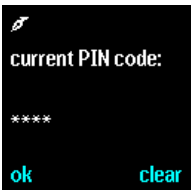
> Key in the PIN code.

> Press **ok**.



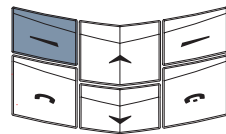
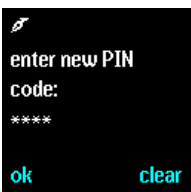

> Key in a four to eight digit number of your choice.

> Press **ok**.

> Key in the number again to verify it.

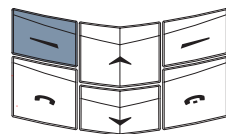
> Press **ok**. A confirmation message appears.



## CALL BARRING SERVICE

(Network service)

The call barring service allows you to restrict the incoming and outgoing calls that you specify.

### SETTING UP THE CALL BARRING SERVICE



*You need to key in the barring password to set up the call barring service. To obtain the barring password, contact your service provider.*

To set up the call barring service:

> From the stand-by display, press **menu**.

> Scroll to **settings**.

> Press **select**.

> Scroll to **security settings**.

> Press **select**.

> Scroll to **call barring service**.

> Press **select**.

> Scroll to one of the following:  
**outgoing calls,**  
**international calls,**  
**international calls except to home country,**  
**incoming calls or incoming calls when abroad.**

> Press **select**.

> Press **activate**.

> Key in the barring password.

> Press **ok**. A confirmation message appears.



*When outgoing calls are barred, calls may be possible to the emergency number programmed into your Vertu phone, for example 112, 911 or other official emergency number.*

To cancel call barring options:

> From the stand-by display, press **menu**.

> Scroll to **settings**.

> Press **select**.

> Scroll to **security settings**.

> Press **select**.

> Scroll to **call barring service**.

> Press **select**.

To cancel a single call barring option:

> Scroll to the required option.

> Press **select**.

> Scroll to **cancel**.

> Press **ok**.

> Key in the barring password.

> Press **ok**. A confirmation message appears.

To cancel all call barring options:

> Scroll to **cancel all barrings**. A confirmation message appears.

## FIXED DIALLING

(Network service)

The fixed dialling feature allows you to restrict outgoing calls to numbers you specify.

### SETTING UP FIXED DIALLING

 You will need to key in the PIN2 code to save and edit numbers in the fixed dialling list. The PIN2 code is supplied with some SIM cards. For more information contact your service provider.

To set up fixed dialling:



security settings  
fixed dialling  
off  
select back

- > From the stand-by display, press **menu**.
- > Scroll to **settings**.
- > Press **select**.
- > Scroll to **security settings**.





- > Press **select**.
- > Scroll to **fixed dialling**.
- > Press **select**.

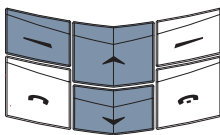

fixed dialling  
on  
off  
number list  
select back

- > Scroll to one of the following: **on**, **off** or **number list**.
- > Press **select**.
- > Key in the PIN2 code.
- > Press **ok**. A confirmation message appears.



 When fixed dialling is activated, calls may be possible to the emergency number programmed into your Vertu phone, for example 112, 911 or other official emergency number.

## CLOSED USER GROUP

(Network service)

The closed user group feature allows you to specify a group of people you can call and who can call you. You can specify more than one group.

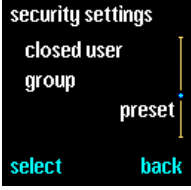

### SETTING UP A CLOSED USER GROUP

To set up a closed user group:

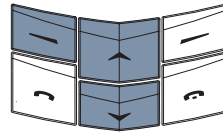

security settings  
closed user group  
preset  
select back

- > From the stand-by display, press **menu**.
- > Scroll to **settings**.
- > Press **select**.
- > Scroll to **security settings**.
- > Press **select**.
- > Scroll to **closed user group**.
- > Press **select**.

closed group  
preset  
on  
off  
ok back

- > Scroll to one of the following: **on**, **off** or **preset**.
- > Press **ok**.
- > Key in the group number.
- > Press **ok**. A confirmation message appears.

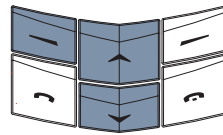

 When outgoing calls are limited to closed user groups, calls may be possible to the emergency number programmed into your Vertu phone, for example 112, 911 or other official emergency number.

For more information on closed user groups, contact your service provider.

## O7 SHORTCUTS, ICONS AND SCREEN SAVER

### SHORT-CUTS

Use the following keypad short-cuts on your Vertu phone to accelerate access to common functions and reduce multiple keypad presses to a single button.

#### FROM THE STAND-BY DISPLAY

To access the directory > Press the upper **SCROLL** key to access the directory at the beginning of the list.

> Press the lower **SCROLL** key to access the directory at the end of the list.

To view a list of recently dialled numbers > Press the **SEND** key.

To activate a profile > Press the **POWER** key once briefly.  
> Scroll to the desired profile.  
> Press **ok**.

#### DURING A CALL

To put the call on hold > Press the **SEND** key.

To unhold the call > Press the **SEND** key.

### WHILE WRITING TEXT MESSAGES

To switch between predictive text input and basic text input > Press and hold **options**.

To switch between upper and lower case > Press the **# +** key.

To switch between letters and numbers > Press and hold the **# +** key.

To insert a number > Press and hold the desired **NUMBER** key until the number appears.

To insert a full stop > Press the **1** key.

To insert a special character or symbol > Press the **\* +** key as many times as needed to insert the desired symbol.

### WHILE VIEWING THE AGENDA

To go to today's date > Press and hold the **# +** key.

### FROM A MENU OR SUBMENU

To return to the stand-by display > Press the **END** key.

## DISPLAY ICONS

Display icons help you identify at a glance the status of your Vertu phone. Some of the features and functions described below are network dependent.

### BATTERY AND SIGNAL ICONS

The battery charge and signal strength icons appear at the top of the display. Beside each of the icons there may be up to five dots.

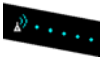

The signal strength icon appears on the left of the display. The more dots there are beside the signal icon, the stronger the network signal.



The battery charge icon appears on the right of the display. The more dots there are beside the battery icon, the higher the charge level.

### STATUS ICONS

One or more of the following icons may appear on the stand-by display below the battery charge and signal strength indicators.

Icons marked with an asterisk (\*) only appear if your SIM card has two lines enabled. For more information contact your service provider.

### IN CALL ICON

The in call icon appears on the right of the display when you are in a call.



You are currently in a call.

## ACTIVE PROFILE ICONS

One of the following active profile icons appears on the left of the display and indicates the currently active profile. For more information see "Profiles" on page 3-20.



**general**



**silent**



**soft**



**loud**



**pager**



**headset.** Only available after the Vertu headset has been connected for the first time.

## ACTIVE FUNCTION ICONS

Active function icons appear on the left of the display and indicate the functions that are currently in use.



The keypad is locked.



No audible alerts will sound for incoming calls or messages.



The speaker phone is active.



The microphone is muted.

## MESSAGE ICONS

Message icons appear on the left of the display and indicate that you have received a text message or a voicemail message.



(Network service) You have received a text message.



(Network service) You have received a voicemail message.



(Network service) You have received a voicemail message on line 1.\*



(Network service) You have received a voicemail message on line 2.\*



(Network service) You have received a voicemail message on both lines 1 and 2.\*

### ALARM CLOCK ICON

The alarm clock icon appears on the right of the display when you have set an alarm using your Vertu phone's alarm clock.

 The alarm clock is set.

### ACTIVE LINE ICONS

Active line icons only appear if your SIM card has two lines enabled. For more information contact your service provider.

 Line 1 is active.\*

 Line 2 is active.\*

### CALL DIVERT ICONS

A call divert icon appears if you have diverted all voice calls to another number, such as your voicemail number.

 You have diverted all voice calls.

 You have diverted all voice calls on line 1.\*

 You have diverted all voice calls on line 2.\*

 You have diverted all voice calls on both lines 1 and 2.\*

### CALL STATUS INDICATORS

While you are in a call some of the following icons may appear beside the caller name or number on the display.

 The call is active.

 The call is on hold.

 The caller has disconnected the call.

 A fax call is active.

 A data call is active.

### DIRECTORY ENTRY TYPE ICONS

Type icons indicate the type of number or text item associated with a directory entry.

The default number for a directory entry is underlined, as in the first example.

When there is an incoming call from a caller whose number is stored in your directory, the icon associated with the number type appears on the display beside the caller's name.

 **general.** The default number. When using the phone memory, this is the only icon shown beside directory entries.

 **general**

 **mobile**

 **home**

 **office**

 **fax**

 **e-mail**

 **postal address**

 **note**

### TEXT MESSAGE ICONS

The following icons may appear in the message lists of a text message folder to indicate the status of the text message.







 (Inbox folder) The text message has not been read.

 (Any other text message folder) The text message has not been sent.

 The text message you sent has been delivered.

### TEXT INPUT ICONS







One or more of the following icons may appear when you are keying in text, for example when writing a text message or adding a directory entry.

-  You are currently using basic text input.
-  You are currently using predictive text input.
-  You are currently using sentence case.
-  You are currently using upper case.
-  You are currently using lower case.
-  You are currently using numeric input.
-  You are currently using special characters.

### PROFILE ICONS



The following profile icons appear beside the profile names, to help you identify which profile to choose.

You can access the profiles list from the profiles menu or by pressing the power key briefly.

-  **general**
-  **silent**
-  **soft**
-  **loud**
-  **pager**
-  **headset.** Only available when you access the profiles list in the profiles menu.
-  **switch off.** Only available when you access the profiles list by pressing the power key briefly.

### AGENDA NOTE ICONS

When setting and viewing agenda notes, the following icons may appear in the agenda note to indicate that an alarm has been set or if the agenda note is set to repeat.

-  The agenda note has an alarm attached.
-  The agenda note is set to repeat at selected intervals.

### PROGRESS INDICATOR

The following progress indicator may appear when your Vertu phone is waiting for a response from the network, for example when sending a text message.

-  The progress indicator animates to show that your Vertu phone is communicating with the network. You should wait before pressing any of the phone's keys.



## SCREEN SAVER

The screen saver is designed to maintain the quality of your Vertu phone's display throughout its lifetime. It ensures that the contents of your display are regularly updated and avoids leaving any pixels (such as those that form the charge or signal strength icons) in a constantly active state. If pixels are held constantly active for a long time, they can become 'ghosted' on the display when they are supposed to be inactive or appear duller when they are active.

The screen saver is automatically activated after a delay since the last key was pressed. You can set this delay to suit your preferences. This delay can be set from 25 seconds to 1 hour. To exit the screen saver, press either of the SELECTION keys.

 *You cannot disable the screen saver function of your Vertu phone.*

When the screen saver is activated, the current display contents are hidden and the screen saver display is shown. If a key is pressed while the screen saver is active, the display contents are automatically restored and no information is lost. The vertical position of the screen saver in the display is shifted every minute to ensure that the screen saver itself does not remain static.

In addition to a key press, some events may trigger the suspension of the screen saver. For example, if you connect the charger, the screen saver is suspended to display the charging confirmation message. After the event, the screen saver waits for the delay time and becomes active again.

## THE SCREEN SAVER DISPLAY



- > 01      Clock – shows the current time. For this component to display properly, the correct local time must be set.
- > 02      Signal strength gauge – shows the signal strength at your current location. The coloured fill level shows the percentage of maximum signal. A solid blue fill indicates a strong signal is being received. A red icon with no fill level indicates that no signal is being received.
- > 03      Moon phase cycle – shows an approximation to the current moon phase. A solid white display represents a full moon and an empty display indicates a new moon (no moon). For this component to display properly, the correct date must be set.
- > 04      Battery charge gauge – shows the remaining charge in your battery. The coloured fill level shows the percentage of maximum charge. A solid blue fill indicates that the battery is fully charged. A red icon and fill level indicates that the battery charge level is below 20% of maximum.
- > 05      Alert bar – shows if a message has been received or a call missed. The alert bar changes from inactive (grey/clear) to active (red) if an event has occurred since the last key press.

## CHANGING THE SCREEN SAVER DELAY

To change the screen saver time delay:

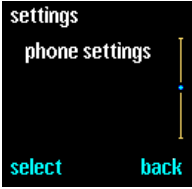

The screenshot shows a black screen with the text 'settings' at the top, 'phone settings' below it, and a vertical scroll bar to the right. At the bottom, there are two cyan buttons labeled 'select' and 'back'.

- > From the stand-by display, press **menu**.
- > Scroll to **settings**.
- > Press **select**.
- > Scroll to **phone settings**.
- > Press **select**.

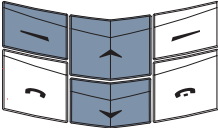

A diagram of a navigation keypad with a central diamond-shaped button and four arrow keys (up, down, left, right) on the top row, and four arrow keys (up, down, left, right) on the bottom row.

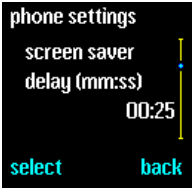

The screenshot shows a black screen with the text 'phone settings' at the top, 'screen saver delay (mm:ss)' below it, and '00:25' to the right of the text. A vertical scroll bar is to the right of the text. At the bottom, there are two cyan buttons labeled 'select' and 'back'.

- > Scroll to **screen saver delay (mm:ss)**.
- > Press **select**.

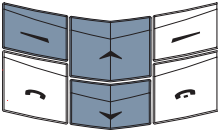

A diagram of a navigation keypad with a central diamond-shaped button and four arrow keys (up, down, left, right) on the top row, and four arrow keys (up, down, left, right) on the bottom row.

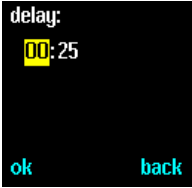

The screenshot shows a black screen with the text 'delay:' at the top, '00:25' below it, and 'ok' and 'back' at the bottom. The '00' is highlighted in yellow.

Enter the delay time in minutes and seconds. Use the scroll keys to toggle between minutes and seconds. The minimum delay is 25 seconds and the maximum is 60 minutes.

- > Press **ok**.

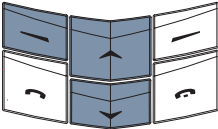

A diagram of a navigation keypad with a central diamond-shaped button and four arrow keys (up, down, left, right) on the top row, and four arrow keys (up, down, left, right) on the bottom row.

 *You cannot disable the screen saver function of your Vertu phone.*

## 08 ADDITIONAL INFORMATION

### SAFETY INFORMATION

#### TRAFFIC SAFETY

Do not use a hand-held telephone while driving a vehicle. If using a hand-held phone park the vehicle before using the phone in any way. Do not place the phone on the passenger seat or where it can break loose in a collision or sudden stop.

The use of an alert device to operate a vehicle's lights or horn on public roads is not permitted.

Remember road safety always comes first!

#### OPERATING ENVIRONMENT

Remember to follow any special regulations in force in any area and always switch off your phone whenever it is forbidden to use it, or when it may cause interference or danger.

When connecting the phone or any accessory to another device, read its user's guide for detailed safety instructions. Do not connect incompatible products.

As with other mobile radio transmitting equipment, users are advised that for the satisfactory operation of the equipment and for the safety of personnel, it is recommended that the equipment should only be used in the normal operating position. When the phone is on and being worn on the body, always use an approved carrying case.

#### ELECTRONIC DEVICES

Most modern electronic equipment is shielded from radio frequency (RF) signals. However, certain electronic equipment may not be shielded against the RF signals from your wireless phone.

#### PACEMAKERS

Pacemaker manufacturers recommend that a minimum separation of 15 cm (6 inches) be

maintained between a hand-held wireless phone and a pacemaker to avoid potential interference with the pacemaker. These recommendations are consistent with the independent research by and recommendations of Wireless Technology Research.

Persons with pacemakers:

- > *Should always keep the phone more than 15 cm (6 inches) from their pacemaker when the phone is switched on;*
- > *Should not carry the phone in a breast pocket;*
- > *Should use the ear opposite the pacemaker to minimize the potential for interference.*

If you have any reason to suspect that interference is taking place, switch off your phone immediately.

#### HEARING AIDS

Some wireless phones may interfere with some hearing aids. In the event of such interference, consult your service provider.

#### OTHER MEDICAL DEVICES

Operation of any radio transmitting equipment, including wireless phones, may interfere with the functionality of inadequately protected medical devices. Consult a physician or the manufacturer of the medical device to determine if they are adequately shielded from external RF energy or if you have any questions.

Switch off your phone in health care facilities when any regulations posted in these areas instruct you to do so. Hospitals or health care facilities may be using equipment that could be sensitive to external RF energy.

#### VEHICLES

RF signals may affect improperly installed or inadequately shielded electronic systems in motor vehicles (e.g. electronic fuel injection systems, electronic anti-skid (anti-lock) braking systems, electronic speed control systems, air bag systems).

Check with the manufacturer or its representative regarding your vehicle. You should also consult the manufacturer of any equipment that has been added to your vehicle.

Do not store or carry flammable liquids, gases or explosive materials in the same compartment as the phone, its parts or accessories.

For vehicles equipped with an air bag, remember that an air bag inflates with great force. Do not place objects, including both installed or portable wireless equipment in the area over the air bag or in the air bag deployment area. If in-vehicle wireless equipment is improperly installed and the air bag inflates, serious injury could result.

**AIRCRAFT**

Switch off your phone before boarding an aircraft. The use of wireless telephones in an aircraft may be dangerous to the operation of the aircraft, disrupt the wireless telephone network and may be illegal. In the United States, FCC regulations prohibit using your Vertu phone while in the air.

Failure to observe these instructions may lead to suspension or denial of telephone services to the offender, or legal action or both.

**POSTED FACILITIES**

Switch your phone off in any facility where posted notices so require.

**POTENTIALLY EXPLOSIVE ATMOSPHERES**

Switch off your phone when in any area with a potentially explosive atmosphere and obey all signs and instructions. Sparks in such areas could cause an explosion or fire resulting in bodily injury or even death.

Users are advised to switch off the phone when at a refuelling point (service station). Users are reminded of the need to observe restrictions on the use of radio equipment in fuel depots (fuel storage and distribution areas), chemical plants or where blasting operations are in progress.

Areas with a potentially explosive atmosphere are often but not always clearly marked. They include below deck on boats; chemical transfer or storage facilities; vehicles using liquified petroleum gas (such as propane or butane); areas where the air contains chemicals or particles, such as grain, dust or metal powders; and any other area where you would normally be advised to turn off your vehicle engine.

**WATER RESISTANCE**



**The accessories designed to be used with your Vertu phone do not meet the same durability or water resistance specifications as the phone itself. For example, chargers can only be used in dry conditions. They should never be used when damp or wet.**

- > You can use your Vertu phone in the rain, but you should not submerge it in water.
- > Before opening the back cover, dry your Vertu phone to prevent water from reaching the interior. The SIM card and battery are not water resistant.
- > Never charge your Vertu phone when the accessories connector is wet or damp.
- > Never use accessories when your Vertu phone is wet or damp.



*Make sure the interior of your Vertu phone and the back cover seals are dry, clean, and free of any foreign objects. Foreign objects may damage the seals against water.*

**SPECIFICATIONS**

|           |                               |
|-----------|-------------------------------|
| Volume    | 78 cc (4.76 in <sup>3</sup> ) |
| Weight    | 173 g (6.10 oz)               |
| Length    | 108 mm (4.25 in)              |
| Width     | 43 mm (1.69 in)               |
| Thickness | 22 mm (0.86 in)               |

**POWER MANAGEMENT**

|                   |                  |
|-------------------|------------------|
| Battery Capacity  | 760 mAh          |
| Maximum talk time | 2.5 to 4 hrs**   |
| Maximum stand-by  | 100 to 150 hrs** |

\*\*Network dependent. Variation in operating time will occur depending on usage and location

## CARE AND MAINTENANCE

Your Vertu products have been crafted from some of the finest materials and care should be taken to keep them in good condition.



**Damage caused to your Vertu phone by failing to observe these care instructions is not covered by the warranty.**

### CERAMICS AND SAPPHIRE

Ceramics and sapphire are very hard materials but are also brittle and can be scratched by harder materials or objects. Furthermore, they can be damaged if dropped.

Avoid the following:

- > *Contact with other hard objects and materials such as diamond jewellery (particularly rings and earrings), nail files, sand paper, abrasives, quartz crystals, metal oxides, nitrides and carbides.*
- > *Dropping or knocking the product on hard surfaces.*
- > *Repeated rubbing against hard surfaces.*

### LEATHER

All Vertu leather products are made by expert craftsmen. Each leather hide is unique and has its own natural characteristics which should be considered part of the individuality of fine leather and not as imperfections or flaws. All leather can be damaged and should be treated with care.

Avoid the following:

- > *Prolonged exposure to water and high humidity.*
- > *Dropping, rubbing or knocking on hard surfaces.*
- > *Exposure to extreme temperatures.*
- > *Contact with oily substances, make-up and solvents.*

### METAL

Vertu metals are finished to a high standard and care needs to be taken to maintain their appearance. Vertu precious metals have a high tarnish resistance but will need polishing to remove fingerprints. Protect in soft cases where possible and polish only with a Vertu recommended polishing cloth.

Avoid the following:

- > *Contact with chemicals such as solvents, alkaline and acid solutions, cola-based drinks and prolonged exposure to salt water. Wipe with a clean, soft cloth as soon as possible if contact occurs.*
- > *Contact with sharp objects.*
- > *Dropping or knocking against hard surfaces.*

### THE MICROFIBRE POLISHING CLOTH

The microfibre polishing cloth is hand washable and is provided for polishing the surfaces and removing fingerprints. The surface **MUST** be free from dust before polishing as dust particles may damage metal surfaces when polished.



***Jewellery cleaner must not be used as this may affect the mechanics of the product and invalidate the warranty.***

### GENERAL CARE TIPS

- > *Keep your Vertu phone dry. Precipitation, humidity and all types of liquids or moisture can contain minerals that will corrode electronic circuits. If your device does get wet, remove the battery and allow the device to dry completely before replacing it.*
- > *Do not use or store your Vertu phone in dusty, dirty areas. Its moving parts and electronic components can be damaged.*
- > *Do not store your Vertu phone in hot areas. High temperatures can shorten the life of electronic components, damage batteries and warp or melt certain plastics.*
- > *Do not store your Vertu phone in cold areas. When your Vertu phone returns to its normal temperature, moisture can form inside and damage the electronics.*
- > *Do not attempt to open your Vertu phone other than as instructed in this guide.*
- > *Do not drop, knock, or shake your Vertu phone. Rough handling can break internal circuit boards and fine mechanics.*

## INDEX

- A**
- ACCESSORIES 5-1**
    - charger 5-2
    - headset 5-1
  - AGENDA 3-31**
    - alerts 3-34
    - anniversary notes 3-36
    - auto erase 3-32
    - call reminders 3-34, 3-35
    - copying text messages to 3-11
    - creating notes 3-33
    - reminder notes 3-33
    - setting the date 3-32
    - setting the time 3-32
    - setting up 3-31
    - viewing day notes 3-33
  - AGENDA NOTES 3-33**
    - accessing 3-37
    - creating 3-33
    - erasing 3-32
    - options 3-33, 3-37, 3-38
  - ALARM CLOCK 3-23**
  - ANNIVERSARY NOTES 3-36**
  - ANSWERING CALLS 1-6**
  - ANYKEY ANSWER 3-25**
  - ARCHIVE FOLDER 3-13**
  - AUDIBLE ALERTS 3-20**
  - AUTOMATIC REDIAL 3-25**
- B**
- BASIC TEXT INPUT 3-3, 3-5**
  - BATTERY 5-4**
    - charge indicator 1-5
    - charging 5-2
    - installation 1-2, 5-5
    - removal 5-4
  - BUSINESS CARDS 2-7**
    - receiving 2-7
    - sending 2-7
- C**
- CALL ALERTS 3-20**
  - CALL BARRING 6-2**
  - CALL COSTS 3-19**
  - CALL DIVERT 3-30**
    - cancel 3-31
    - options 3-30
  - CALL DURATION 3-19**
  - CALL HOLDING 4-5**
  - CALL LISTS 3-18**
    - erasing 3-19
    - erasing numbers 3-18
    - viewing numbers 3-18
  - CALL REGISTER 3-17**
    - options 3-19
    - time of all 3-18
  - CALL SETTINGS 3-25**
    - anykey answer 3-25
    - automatic redial 3-25
    - call waiting 3-26
    - own number sending 3-26
    - speed dialling 3-25
  - CALL WAITING 3-26, 4-3**
    - activating 4-3
    - ending both calls 4-4
    - swapping between calls 4-4
    - using 4-4
  - CALLER GROUPS 2-10**
    - adding individual entries 2-11
    - adding names 2-11
    - removing a name 2-11
    - renaming 2-12
    - setting ringing tones 2-12
  - CALLS**
    - answering 1-6
    - dialled numbers 3-17
    - emergency 1-7
    - ending or rejecting 1-6
    - missed 3-17
    - received 3-17
  - CHARGER 5-2**
  - CHARGING**
    - battery 5-4
  - CLOCK 3-24**
    - alarm 3-23
    - changing the time 3-24
    - display 3-24
    - hide 3-24
    - setting 1-4
  - COMMUNICATION SETTINGS 3-28**
  - COMPUTER, CONNECTING TO 5-3**
  - CONCIERGE 1-9**
  - CONCIERGE KEY 1-9**
  - CONFERENCE CALLS 4-7**
  - COPYING DIRECTORY ENTRIES 2-8**
  - COPYING ENTRIES 2-8, 2-9**
    - all 2-9
    - default only 2-9
    - individually 2-9
    - one by one 2-8
- D**
- DATA CABLE 5-3**
  - DEFAULT SETTINGS, RESTORING 3-29**
  - DELIVERING TEXT MESSAGES 3-16**
  - DELIVERY REPORTS 3-16**
  - DIALLED NUMBERS 3-17**
  - DIALLING 1-6**
  - DIRECTORY 2-1, 2-5**
    - making a call from 2-5
    - multiple entries 2-3
    - organising 2-8
  - DIRECTORY ENTRIES**
    - accessing 2-2
    - adding 2-2
    - adding text to 2-4
    - changing number type 2-13
    - changing the default number 2-4
    - copying 2-8
    - editing 2-12
    - editing a name 2-13
    - editing a number 3-18
    - erasing 2-13
    - searching for 2-2, 2-5
  - DIRECTORY VIEW 2-5**
  - DISPLAY ICONS 1-5, 7-2**
- E**
- EDITING**
    - a name 2-13
    - a number 2-12
    - templates 3-13
    - text messages 3-11
  - EMERGENCY CALLS 1-7**
  - ERASING**
    - a number 2-13
    - call lists 3-19
    - directory entries 2-13
    - personal folders 3-15
    - text messages 3-6, 3-15

- F**
- FIXED DIALLING** 6-2
  - FOLDERS**
    - archive 3-13
    - inbox 3-12
    - moving text messages 3-11
    - outbox 3-12
    - personal 3-14
    - template 3-13
    - text message 3-12
  - FORWARDING, TEXT MESSAGES** 3-10
- G**
- GROUPS, CALLER** 2-10
- H**
- HEADSET** 3-22, 5-1
  - HOLDING YOUR PHONE** 2-6
- I**
- ICONS** 7-2
    - display 1-5
    - profile 3-20
  - IN CALL FUNCTIONS** 4-5
  - INBOX FOLDER** 3-12
  - INDICATORS** 7-3
    - battery charge 1-5
    - signal strength 1-5
  - INSTALLATION**
    - battery 1-2, 5-5
    - SIM card 1-2
  - INTERNATIONAL CALLS** 1-6
- K**
- KEYPAD** 1-3
    - lock 1-8
    - unlock 1-8
  - KEYS**
    - Concierge 1-1
    - power 1-4
    - selection 1-1, 1-3, 7-5
- L**
- LANGUAGE** 3-28
  - LAST NUMBER REDIAL** 1-6
  - LOCKING, KEYPAD** 1-8
- M**
- MAKING A CALL** 1-6
  - MAKING MULTIPLE CALLS** 4-6
  - MEMORY**
    - phone 2-1
    - SIM card 2-1
  - MENUS**
    - options 3-1
    - using 3-2
  - MESSAGE CENTRE NUMBER** 3-16
  - MESSAGE PROFILES** 3-5, 3-16, 3-17
  - MESSAGE SETTINGS** 3-15
  - MICROPHONE** 1-1
  - MISSED CALLS** 3-17
  - MODEM, USING YOUR PHONE AS** 5-3
  - MULTIPLE CALLS**
    - ending both calls 4-6
    - making 4-6
    - swapping between calls 4-6
  - MUTE** 4-5
- N**
- NAMES, SEE DIRECTORY ENTRIES** 2-2
  - NETWORK SELECTION** 3-27
  - NETWORK SERVICES**
    - call barring 6-2
    - call costs 3-19
    - call divert 3-30
    - call holding 4-5
    - call waiting 4-3
    - closed user group 6-2
    - conference calls 4-7
    - fixed dialling 6-2
    - info service 3-28
    - messages 3-3
    - own number sending 3-26
    - PIN2 code 6-2
    - SIM services 3-40
    - transferring calls 4-6
    - voicemail 3-29
  - NUMBER KEYS** 1-3
  - NUMBERS**
    - using in text messages 3-11
- O**
- OUTBOX FOLDER** 3-12
- P**
- PAUSE AND WAIT COMMANDS** 4-8
    - options 4-7
    - setting up 4-8
    - using 4-9
  - PERSONAL FOLDERS** 3-14
    - accessing 3-14
    - adding 3-14
    - erasing 3-15
    - opening 3-14
    - renaming 3-14
  - PERSONALISING PROFILES** 3-20
  - PHONE MEMORY** 2-1
    - changing number type 2-13
    - checking status 2-10
    - copying to SIM card memory 2-8
  - PHONE SETTINGS** 3-26
  - PIN CODE**
    - entering your 1-4
  - PIN CODES** 6-1
  - PREDICTIVE TEXT INPUT** 3-7
    - options 3-9
  - PROFILES** 3-19, 3-20
    - activating 3-20
    - personalising 3-20
    - renaming 3-22
- R**
- READING TEXT MESSAGES**
    - options 3-10
  - RECEIVED CALLS** 3-17
  - REJECTING CALLS** 1-6
  - REMINDER NOTES** 3-33
  - REMOVING**
    - battery 5-4
    - personal folders 3-15
  - RENAMING**
    - personal folders 3-14
    - profiles 3-22
  - REPLYING, TO TEXT MESSAGES** 3-10
  - RINGING TUNE**
    - setting 3-21
    - setting for groups 2-12

- S**
- SAVING, TEXT MESSAGES** 3-6
  - SCREEN SAVER** 7-5
  - SCREEN SAVER DELAY** 7-6
  - SECURITY** 6-1
    - call barring service 6-2
    - closed user group 6-2
    - fixed dialling 6-2
    - levels 6-1
    - PIN code 6-1
    - PIN2 code 6-2
  - SECURITY CODES** 6-3
  - SECURITY SETTINGS** 3-29
  - SELECTING, MEMORY TYPE** 2-1
  - SENDING**
    - business cards 2-7
    - text messages 2-6, 3-5
  - SETTING**
    - audible alerts 3-20
    - group ringing tunes 2-12
    - message alerts 3-21
    - ringing tunes 3-21
    - time 1-4
    - vibrating alert 3-21
    - volume 3-21
    - warning tones 3-21
  - SETTINGS** 3-22, 3-23
    - language 3-26
    - network selection 3-27
    - security 3-29
    - time 3-25
    - welcome note 3-27
  - SHORT-CUTS** 7-1
  - SIGNAL STRENGTH INDICATOR** 1-5
  - SIM CARD**
    - changing the 1-4
    - installation 1-2
  - SIM CARD MEMORY** 2-1
    - checking status 2-10
    - copying to phone memory 2-8
  - SIM SERVICES** 3-40
  - SPEAKER PHONE** 4-3
  - SPEED DIALLING** 2-8, 3-25, 4-1
    - activating 4-1
    - assigning numbers 4-1
    - options 4-2
    - viewing assigned entries 4-2
  - SWAPPING BETWEEN CALLS** 4-6
  - SWITCHING ON** 1-4
- T**
- TEMPLATES** 3-6, 3-13
    - editing 3-13
  - TEXT MESSAGES** 3-3
    - alert tones 3-21
    - changing titles of 3-11
    - clear text 3-6
    - copying to agenda 3-11
    - delivery reports 3-16
    - editing 3-11
    - erasing multiple 3-15
    - exiting 3-6
    - forwarding 3-10
    - inserting entry 3-6
    - inserting information from directory 3-6
    - inserting number 3-6
    - inserting templates 3-6
    - language settings 3-28
    - message delivery 3-16
    - moving to folders 3-11
    - predictive text input 3-7
    - profiles 3-17
    - reading 3-9
    - replying to 3-10
    - saving 3-6
    - sending 2-6, 3-3, 3-5, 3-18
    - setting format 3-16
    - settings 3-15
    - using numbers in 3-11
  - TIME** 3-23, 3-24
    - changing the time 3-24
    - setting 1-4
    - setting the format 3-25
  - TONES**
    - message alert 3-21
    - warning 3-21
  - TRANSFERRING CALLS** 4-6
  - TUNES** 3-21
- U**
- UNLOCKING, KEYPAD** 1-8
- V**
- VERTU CONCIERGE** 1-9
  - VIBRATING** 3-21
  - VIEWING DIRECTORY ENTRIES** 2-5
  - VOICE MAILBOX NUMBER** 3-29
  - VOICEMAIL** 1-7
    - listening to messages 3-29
  - VOLUME** 3-21
    - adjusting 1-6
- W**
- WARNING TONES** 3-21
  - WELCOME NOTE** 3-27
  - WRITING TEXT MESSAGES** 3-3
    - using basic text input 3-3
    - using predictive text input 3-7