

ALPINE®

MARINE

Marine CD Receiver

CDA-118M



iPhone 3GS
16GB 32GB



iPhone 3G
8GB 16GB



iPhone
4GB 8GB 16GB

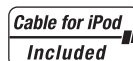

- **OWNER'S MANUAL**
Please read before using this equipment.
- **MODE D'EMPLOI**
Veuillez lire avant d'utiliser cet appareil.
- **MANUAL DE OPERACIÓN**
Léalo antes de utilizar este equipo.

ALPINE ELECTRONICS MARKETING, INC.
1-1-8 Nishi Gotanda,
Shinagawa-ku,
Tokyo 141-0031, Japan
Phone 03-5496-8231

ALPINE ELECTRONICS OF AMERICA, INC.
19145 Gramercy Place, Torrance,
California 90501, U.S.A.
Phone 1-800-ALPINE-1 (1-800-257-4631)

ALPINE ELECTRONICS OF CANADA, INC.
777 Supertest Road, Toronto,
Ontario M3J 2M9, Canada
Phone 1-800-ALPINE-1 (1-800-257-4631)

ALPINE ELECTRONICS OF AUSTRALIA PTY. LTD.
161-165 Princes Highway, Hallam
Victoria 3803, Australia
Phone 03-8787-1200

ALPINE ELECTRONICS GmbH
Wilhelm-Wagenfeld-Str. 1-3, 80807 München,
Germany
Phone 089-32 42 640

ALPINE ELECTRONICS OF U.K. LTD.
Alpine House
Fletchamstead Highway, Coventry CV4 9TW, U.K.
Phone 0870-33 33 763

ALPINE ELECTRONICS FRANCE S.A.R.L.
(RCS PONTOISE B 338 101 280)
98, Rue de la Belle Etoile, Z.I. Paris Nord II,
B.P. 50016, 95945 Roissy Charles de Gaulle
Cedex, France
Phone 01-48638989

ALPINE ITALIA S.p.A.
Viale C. Colombo 8, 20090 Trezzano
Sul Naviglio (MI), Italy
Phone 02-484781

ALPINE ELECTRONICS DE ESPAÑA, S.A.
Portal de Gamarra 36, Pabellón, 32
01013 Vitoria (Alava)-APDO 133, Spain
Phone 945-283588

ALPINE ELECTRONICS (BENELUX) GmbH
Leuvensesteenweg 510-B6,
1930 Zaventem, Belgium
Phone 02-725-13 15

EN

FR

ES

Contents

Operating Instructions

WARNING

WARNING	4
CAUTION	4
PRECAUTIONS	4

Getting Started

Accessory List	7
Turning Power On and Off	7
Initial System Start-Up	7
Multi-Zone Volume Control	7
Adjusting Volume	7
Lowering Volume Quickly	7
About Auto Save	7
Setting the Quick Search ON and OFF	8

Radio

Listening to Radio	8
Presetting Stations Manually	9
Presetting Stations Automatically	9
Tuning to Preset Stations	9
Frequency Search Function	9
Receiving a Multicast Station (HD Radio™ mode only)	10
Changing the Display (HD Radio mode only)	10

CD/MP3/WMA/AAC

Playback	10
Repeat Play	11
M.I.X. (Random Play)	11
Searching for CD Text	11
File/Folder Name Search (Concerning MP3/WMA/AAC)	12
Quick Search	12
Select the desired Folder (Folder up/down) (MP3/WMA/AAC)	12
Changing the Display	12
About MP3/WMA/AAC	13

iPhone/iPod (Optional)

Playback	15
Searching for a desired Song	15
Quick Search	16
Percent Skip Function	16
Alphabet Skip Function	16
Up/Down Function	16
Search Position Memory	16
Random Play Shuffle (M.I.X.)	17
Random Play Shuffle All	17
Repeat Play	17
Changing the Display	17

USB memory (Optional)

Controlling USB memory (Optional)	18
Playing MP3/WMA/AAC Files with the USB memory (Optional)	18
Search Position Memory	18

Hands-Free Phone Operation

About the Hands-Free Phone	18
Answering a Call	18
Hanging up the Telephone	18
Adjusting the volume when receiving a Call	19
Redial Function	19
Audio Switching Operation	19
Call History	19

Sound Setting

Adjusting Subwoofer/Bass/Treble/Balance (Between Left and Right)/Fader (Between Front and Rear)/ Loudness/Defeat	20
Turning Subwoofer ON/OFF	21
Setting the Subwoofer System	21
Setting the Bass Control	21
Setting the Treble Control	22
Adjusting the High Pass Filter	22

SETUP

BLUETOOTH Setting

Setting the BLUETOOTH Connection 23

Audio Setting

AUX Zone Select (AUX ZONE SELECT) 24
Setting the MUTE Level (MUTE LEVEL) 24
Operating the External Audio Processor
(USER PRESET) 24
Turning Media Xpander ON/OFF 24
Setting the MX Level 24
Subwoofer On and Off 24

General Setting

Setting TUNER mode (TUNER) 24
Playing MP3/WMA/AAC Data
(PLAY MODE) 24
Sound (Beep) Guide Function 24
Turning Mute Mode On/Off (INT MUTE) 24
Setting the AUX+ Mode 24
Setting the AUX+ NAME Mode 24
Setting the AUX ZONE Mode 24
Setting the AUX ZONE NAME mode 25
Setting the AUX Mode (V-Link) 25
Setting the Changer Name 25
Setting the External Digital Input
(DIGITAL AUX) 25
Setting the AUX+ Level (AUX IN GAIN) 25
Connecting to an External Amplifier
(POWER IC) 25
Demonstration 25

Display Setting

Volume Level Bar Setting (VOL DISP) 25
Changing Lighting Color
(ILLUMINATION) 26
Dimmer Control (DIMMER) 26
Dimmer Level Setting (DIMMER LEVEL) 26
Scroll Type Setting (SCROLL TYPE) 26
Scroll Setting (TEXT SCROLL) 26

iPod Setting

iPod Search Mode Setting 26

SIRIUS Radio Setting (Only when a SIRIUS Receiver Box is connected)

Unlock the Locked Channels
(CLEAR LOCK) 26
Clearing the Setting of Skipped Channels
(CLEAR SKIP) 26
Setting the Favorite Sports Team announcement
(SPORTS) 26
Setting the Sirius Seek (S-SEEK) Alert 27

HD Radio Reception Setting (Only when HD Radio tuner module receiver is connected)

HD Radio Station Call Setting 27
Digital Seek On/Off Setting 27

SAT Radio Receiver (Optional)

Receiving Channels with the SAT Radio Receiver (Optional) 28
Checking the SAT Radio ID Number 28
Storing Channel Presets 28
Receiving Stored Channels 29
Storing the desired Sports Team
(SIRIUS only) 29
Storing the desired Song / Artist
(SIRIUS only) 29
Activating the stored Alert (SIRIUS only) 30
Search Function 30
Quick Search Function 30
Select the desired CATEGORY
(Category up/down) 30
Receiving Weather or Traffic Information from SAT Radio 31
Instant Replay Function (SIRIUS only) 31
Changing the Display 31
Setting the Auxiliary Data Field Display
(XM only) 32

IMPRINT Operation (Optional)

Changing MultEQ mode	32
Adjusting Sound Setting in Manual Mode	33
USER PRESET	33
Storing the Audio Adjustment Level	33
Recalling the Audio Adjustment Level	33
Turning Media Xpander ON/OFF	33
Equalizer Presets (Factory's EQ)	
(FR-EQ)	33
Sound Field Adjustment	34
Adjusting the Parametric Equalizer Curve	34
Adjusting the Graphic Equalizer Curve	34
Adjusting the Time Correction	34
Adjusting the Crossover Settings	
(X-OVER)	35
Turning Subwoofer ON/OFF	36
Setting the Subwoofer System	36
Setting the Subwoofer Phase	36
Setting the Subwoofer Channel	
(SUBW CHANNEL)	36
Setting the Response Slope for the	
High Range Speaker (TW Setup)	36
Setting EQ mode	36
Setting the Filter type	36
Setting the Time Correction Unit	
(TCR Parameter)	36
Setting the MX Level	36
About Time Correction	37
About the Crossover	38

Changer (Optional)

Selecting a Disc (Changer) (Optional)	39
Playing MP3 Files with the CD Changer	
(Optional)	39
Multi-Changer Selection (Optional)	39

Information

In Case of Difficulty	40
Specifications	44

Installation and Connections

Warning	45
Caution	45
Precautions	45
Installation	46
Connections	47

LIMITED WARRANTY

Operating Instructions

WARNING

WARNING

This symbol means important instructions. Failure to heed them can result in serious injury or death.

DO NOT OPERATE ANY FUNCTION THAT TAKES YOUR ATTENTION AWAY FROM SAFELY DRIVING YOUR BOAT.

Any function that requires your prolonged attention should only be performed after coming to a complete stop. Always stop the boat in a safe location before performing these functions. Failure to do so may result in an accident.

KEEP THE VOLUME AT A LEVEL WHERE YOU CAN STILL HEAR OUTSIDE NOISES WHILE DRIVING.

Excessive volume levels that obscure sounds such as emergency boat sirens or approaching vessels can be dangerous and may result in an accident. LISTENING AT LOUD VOLUME LEVELS IN A BOAT MAY ALSO CAUSE HEARING DAMAGE.

MINIMIZE DISPLAY VIEWING WHILE DRIVING.

Viewing the display may distract the driver from looking ahead of the boat and cause an accident.

DO NOT DISASSEMBLE OR ALTER.

Doing so may result in an accident, fire or electric shock.

DO NOT CONNECT A POWER SUPPLY OTHER THAN A DC 12V NEGATIVE GROUND TYPE.

Failure to do so may result in accident or fire.

KEEP SMALL OBJECTS SUCH AS BOLTS OR SCREWS OUT OF THE REACH OF CHILDREN.

Swallowing them may result in serious injury. If swallowed, consult a physician immediately.

USE THE CORRECT AMPERE RATING WHEN REPLACING FUSES.

Failure to do so may result in fire or electric shock.

DO NOT BLOCK VENTS OR RADIATOR PANELS.

Doing so may cause heat to build up inside and may result in fire.

USE THIS PRODUCT FOR MOBILE 12V APPLICATIONS.

Use for other than its designed application may result in fire, electric shock or other injury.

DO NOT PLACE HANDS, FINGERS OR FOREIGN OBJECTS IN INSERTION SLOTS OR GAPS.

Doing so may result in personal injury or damage to the product.

CAUTION

This symbol means important instructions. Failure to heed them can result in injury or material property damage.

HALT USE IMMEDIATELY IF A PROBLEM APPEARS.

Failure to do so may cause personal injury or damage to the product. Return it to your authorized Alpine dealer or the nearest Alpine Service Center for repairing.

PRECAUTIONS

Product Cleaning

Use a soft dry cloth for periodic cleaning of the product. For more severe stains, please dampen the cloth with water only. Anything else has the chance of dissolving the paint or damaging the plastic.

Temperature

Be sure the temperature inside the boat is between +60°C (+140°F) and -10°C (+14°F) before turning your unit on.

Moisture Condensation

You may notice the CD playback sound wavering due to condensation. If this happens, remove the disc from the player and wait about an hour for the moisture to evaporate.

Damaged Disc

Do not attempt to play cracked, warped, or damaged discs. Playing a bad disc could severely damage the playback mechanism.

Maintenance

If you have problems, do not attempt to repair the unit yourself. Return it to your Alpine dealer or the nearest Alpine Service Station for servicing.

Never Attempt the Following

Do not grip or pull out the disc while it is being pulled back into the player by the automatic reloading mechanism.

Do not attempt to insert a disc into the unit when the unit power is off.

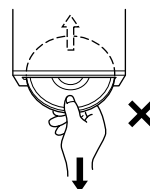

Inserting Discs

Your player accepts only one disc at a time for playback. Do not attempt to load more than one disc.

Make sure the label side is facing up when you insert the disc. "ERROR" will be displayed on your player if you insert a disc incorrectly. If "ERROR" continues to be displayed even though the disc has been inserted correctly, push the RESET switch with a pointed object such as a ballpoint pen.

Playing a disc while driving on a very bumpy road may result in skips, but this will not scratch the disc or damage the player.

New Discs

To prevent the CD from jamming, "ERROR" is displayed if discs with irregular surfaces are inserted or if discs are inserted incorrectly. When a new disc is ejected immediately after initial loading, use your finger to feel around the inside of the center hole and outside edge of the disc. If you feel any small bumps or irregularities, this could inhibit proper loading of the disc. To remove the bumps, rub the inside edge of the hole and outside edge of the disc with a ballpoint pen or other such instrument, then insert the disc again.

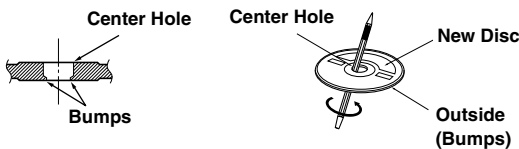

Irregular Shaped Discs

Be sure to use round shape discs only for this unit and never use any special shape discs.

Use of special shape discs may cause damage to the mechanism.



Installation Location

Make sure this unit will not be installed in a location subjected to:

- Direct sun and heat
 - High humidity and water
 - Excessive dust
 - Excessive vibrations
-

Correct Handling

Do not drop the disc while handling. Hold the disc so you will not leave fingerprints on the surface. Do not affix tape, paper, or gummed labels to the disc. Do not write on the disc.

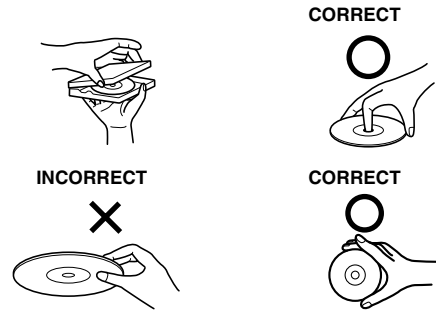

Disc Cleaning

Fingerprints, dust, or soil on the surface of the disc could cause the CD player to skip. For routine cleaning, wipe the playing surface with a clean, soft cloth from the center of the disc to the outer edge. If the surface is heavily soiled, dampen a clean, soft cloth in a solution of mild neutral detergent before cleaning the disc.



Disc Accessories

There are various accessories available on the market for protecting the disc surface and improving sound quality. However, most of them will influence the thickness and/or diameter of the disc. Using such accessories can cause the disc to be out of standard specifications and may create operational problems. We recommend not using these accessories on discs played in Alpine CD players.

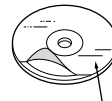

Transparent Sheet

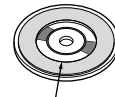

Disc Stabilizer

On handling Compact Discs (CD/CD-R/CD-RW)

- Do not touch the surface.
- Do not expose the disc to direct sunlight.
- Do not affix stickers or labels.
- Clean the disc when it is dusty.
- Make sure that there are no bumps around the disc.
- Do not use commercially available disc accessories.

Do not leave the disc in the boat or the unit for a long time. Never expose the disc to direct sunlight. Heat and humidity may damage the CD and you may not be able to play it again.

To customers using CD-R/CD-RW

- If a CD-R/CD-RW cannot be played back, make sure the last recording session was closed (finalized).
- Finalize the CD-R/CD-RW if necessary, and attempt playback again.

About media that can be played

Use only compact discs with the label side showing the CD logo marks below.



If you use unspecified compact discs, correct performance cannot be guaranteed.

You can play CD-Rs (CD-Recordables)/CD-RWs (CD-ReWritables) which have been recorded only on audio devices. You can also play CD-Rs/CD-RWs containing MP3/WMA/AAC formatted audio files.

- Some of the following CDs may not play on this unit:
Flawed CDs, CDs with fingerprints, CDs exposed to extreme temperatures or sunlight (e.g., left in the boat or this unit), CDs recorded under unstable conditions, CDs on which a recording failed or a re-recording was attempted, copy-protected CDs which do not conform to the audio CD industry standard.
- Use discs with MP3/WMA/AAC files written in a format compatible with this unit. For details, see pages 13-14.
- ROM data other than audio files contained in a disc will not produce sound when played back.

Protecting the USB connector

- Only a USB memory iPhone/iPod can be connected to the USB connector on this unit. Correct performance using other USB products cannot be guaranteed.
- If the USB connector is used, be sure to connect it to the unit by using a USB extension cable (supplied). A USB hub is not supported.
- Depending on the connected USB memory device, the unit may not function or some functions may not be performed.
- The audio file format that can be played back on the unit is MP3/WMA/AAC.
- Artist/song name, etc., can be displayed; certain, special characters may not be correctly displayed.



Alpine accepts no responsibility for lost data, etc., even if data, etc., is lost while using this product.

On Handling USB Memory

- To prevent malfunction or damage, note the following points.
Read the USB memory Owner's Manual thoroughly.
Do not touch the terminals by hand or metal.
Do not subject USB memory to excessive shock.
Do not bend, drop, disassemble, modify or soak in the water.
- Avoid usage or storage in the following locations:
Anywhere in the boat exposed to direct sunlight or high temperatures.
Anywhere the possibility of high humidity or corrosive substances are present.
- Fix the USB memory in a location where driver operation will not be hindered.
- USB memory may not function correctly at high or low temperature.
- Use only certified USB memory. Note that even certified USB memory, may not function correctly depending on its type or state.

- USB memory function is not guaranteed. Use USB memory according to the terms of agreement.
- Depending on the settings of the USB memory type, memory state or encoding software, the unit may not play back or display properly.
- A file that is copy-protected (copyright protection) cannot be played back.
- USB memory may take time to start playback. If there is a particular file other than audio in the USB memory, it may take considerable time before the file is played back or searched.
- The unit can play back "mp3", "wma" or "m4a" file extensions.
- Do not add the above extensions to a file other than audio data. This non-audio data will not be recognized. The resulting playback may contain noise that can damage speakers and/or amplifiers.
- It is recommended to back up important data on a personal computer.
- Do not remove the USB device while playback is in progress. Change SOURCE to something other than USB, then remove the USB device to prevent possible damage to its memory.

-
- *Windows Media and the Windows logo are trademarks, or registered trademarks of Microsoft Corporation in the United States and/or other countries.*
 - *iPod and iTunes are trademarks of Apple Inc., registered in the U.S. and other countries.*
 - *iPhone is a trademark of Apple Inc.*
 - *"Made for iPod" means that an electronic accessory has been designed to connect specifically to iPod and has been certified by the developer to meet Apple performance standards.*
 - *"Works with iPhone" means that an electronic accessory has been designed to connect specifically to iPhone and has been certified by the developer to meet Apple performance standards.*
 - *Apple is not responsible for the operation of this device or its compliance with safety and regulatory standards.*
 - *The BLUETOOTH® word mark and logos are registered trademarks owned by the Bluetooth SIG, Inc. and any use of such marks by Alpine Electronics, Inc. is under license.*
 - *HD Radio™ and the HD and HD Radio Ready logos are proprietary trademarks of iBiquity Digital Corp.*
 - *"MPEG Layer-3 audio coding technology licensed from Fraunhofer IIS and Thomson."*
 - *"Supply of this product only conveys a license for private, non-commercial use and does not convey a license nor imply any right to use this product in any commercial (i.e. revenue-generation) real time broadcasting (terrestrial, satellite, cable and/or any other media), broadcasting/streaming via internet, intranets and/or other networks or in other electronic content distribution systems, such as pay-audio or audio-on-demand applications. An independent license for such use is required. For details, please visit <http://www.mp3licensing.com>"*
 - *Audyssey MultEQ XT is a registered trademark of Audyssey Laboratories Inc.*

Getting Started

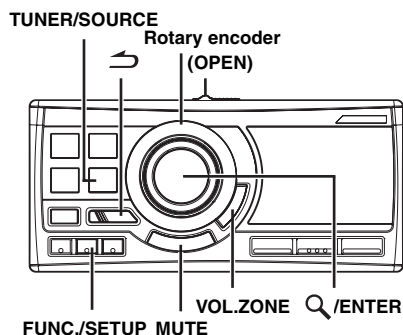

Accessory List

- Marine CD receiver 1
- Power cable 1
- USB cable 1
- Interface cable for iPod 1
- Rubber Cap 1
- Hex Bolt 1
- Screw (M4x30) 6
- Support Strap 1
- Installation Template 1
- Owner's Manual 1 set

Turning Power On and Off

Press **TUNER/SOURCE** to turn on the unit.

- The unit can be turned on by pressing any other button except Rotary encoder.

Press and hold **TUNER/SOURCE** for at least 2 seconds to turn off the unit.

- The first time power is turned on, the volume will start from level 12.

Initial System Start-Up

Be sure to press the RESET switch when using the unit for the first time, after changing the boat battery, etc.

- 1 Turn off the unit power.
- 2 Slide **(OPEN)** to open the front panel.
- 3 Press **RESET** with a ballpoint pen or similar pointed object.

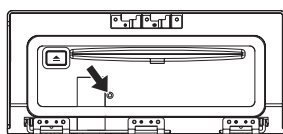

Multi-Zone Volume Control

Press **VOL.ZONE** to switch the volume mode, and the appropriate indicator lights up.

ALL → ZONE1 → ZONE2 → ALL

- ALL : All Speaker Volume control (Front, Rear, Subwoofer, ZONE2 Speaker).
- ZONE1 : Volume control for 3 Preouts (Front, Rear, Subwoofer).
- ZONE2 : Volume control for ZONE2 Speakers only (ZONE2 Speaker).

- When the ZONE1 or ZONE2 is selected, its Volume Level is adjustable, and another Volume Level is fixed.
- If ALL is selected, when the Volume Level for ZONE1 and ZONE2 is different, the Volume Level that reaches to 0/35 cannot be adjustable.

Adjusting Volume

Turn the **Rotary encoder** until the desired sound is obtained.

Lowering Volume Quickly

Activating the Audio mute function will quickly lower the volume level. The unit has 3 mute modes and 6 mute levels.

Press and hold **MUTE** for at least 2 seconds to select one of the three MUTE modes.

Press **MUTE** to activate the selected mode.

ALL → ZONE1 → ZONE2 → ALL

- ALL : ZONE1 and ZONE2 Enter Mute mode.
- ZONE1 : Only ZONE1 Enters Mute mode.
- ZONE2 : Only ZONE2 Enters Mute mode.

Press **MUTE** again, and the mute function is canceled.

- For the Mute Level, refer to "Setting the MUTE Level (MUTE LEVEL)" (page 24).

About Auto Save

The adjusting/setting content of items in the table below will remain even when the battery is disconnected.

- The setting content of the items with "*" will be saved in 10 seconds after setting.

Items to be adjusted/set	Reference page
Multi-Zone Volume Control*	page 7
Lowering Volume Quickly*	page 7
Adjusting Subwoofer/Bass/Treble/Balance (Between Left and Right)/Fader (Between Front and Rear)/Loudness/Defeat	page 20
Setting the Bass Control	page 21
Setting the Treble Control	page 22
Adjusting the High Pass Filter	page 22
Search Position Memory	page 16, page 18
Presetting Stations Manually	page 9
SETUP Setting	page 23~page 27

Setting the Quick Search ON and OFF

- 1 Press **FUNC./SETUP**.
 - 2 Turn the **Rotary encoder** to select **QUICK SEARCH**, and then press **Q/ENTER**.
 - 3 Turn the **Rotary encoder** to select **ON** or **OFF**, and then press **Q/ENTER**.
 - 4 Press **FUNC./SETUP** to return to normal mode.
- Pressing ↶ during the procedure will return to the previous mode.
 - If no operation is performed for 60 seconds, the unit will return to normal mode automatically.
 - Operation is not required during Radio, HD Radio reception, CD or CD Changer mode.

Controllable With Remote Control

This unit can be controlled with an optional Alpine remote control. For details, consult your Alpine dealer. Point the optional remote control transmitter at the remote control sensor.

Remote control sensor

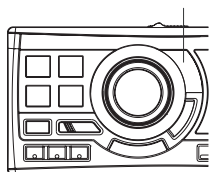

Radio

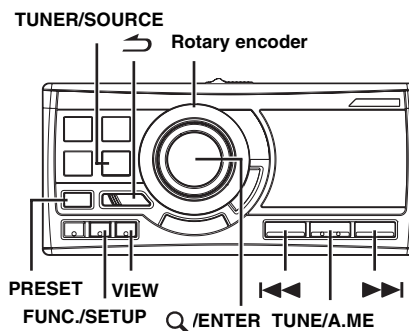

This unit cannot receive HD Radio signals (digital terrestrial radio). In order to activate the digital radio functions described below, an optional HD Radio Tuner module must be connected through the Ai-NET bus.

iTunes Tagging lets you tag songs you hear on HD Radio stations with your new CDA-118M and then preview, buy, and download them later from your iTunes Tagged playlist the next time you sync your iPod.

If the unit is connected to a Tagging compatible device, you can use the iTunes Tagging function. For details, refer to the Owner's Manual of the Tagging compatible device.

- The frequency area can be changed by setting *MODE1* or *MODE2* in Tuner mode. For details, refer to "Setting TUNER mode (TUNER)" (page 24).

Listening to Radio

HD Radio signals can be received if the HD Radio TUNER MODULE (TUA-T500HD or TUA-T550HD) is connected. While receiving HD Radio signals, the unit can automatically switch between the analog and digital signal.

- 1 Press **TUNER/SOURCE** to select the desired radio band (**FM** or **AM**).

FM*¹ → AM → AUX ZONE*² → AUX*³ → BT AUDIO*⁴ → FM

- *¹ When an optional HD Radio tuner module is connected, the *FM1*, *FM2* can be selected.
- *² Displayed only when the *AUX ZONE* is set to *ON*, refer to "Setting the *AUX ZONE* Mode" (page 24).
- *³ Displayed only when the *AUX* is set to *ON*, refer to "Setting the *AUX* Mode (*V-Link*)" (page 25).
- *⁴ Displayed only when *BT IN* is set to *ADPT*, refer to "BLUETOOTH Setting" (page 23).

2 Press **TUNE/A.ME** to select the tuning mode.

DX SEEK (Distance mode) → SEEK (Local mode) →
(Blank) (Manual mode) → DX SEEK (Distance mode)

- *The initial mode is Distance mode.*

Distance mode:

Both strong and weak stations will be automatically tuned in (Automatic Seek Tuning).

Local mode:

Only strong stations will be automatically tuned in (Automatic Seek Tuning).

Manual mode:

The frequency is manually tuned in steps (Manual tuning).

3 Press **◀◀** or **▶▶** to tune in the desired station.

Holding down **◀◀** or **▶▶** will change the frequency continuously.

- *If DIGITAL SEEK is set to ON, the SEEK UP/DOWN functions only stop on digital station frequencies while receiving an HD Radio signal. Refer to "Digital Seek On/Off Setting" (page 27).*

Presetting Stations Manually

1 Select the radio band and tune in a desired radio station you wish to store in the preset memory.

2 Press and hold **PRESET** for at least 2 seconds.
The Preset screen is displayed.

3 Turn the **Rotary encoder** to select the preset number.

4 Press and hold **Q/ENTER** for at least 2 seconds.
The selected station is stored.
The display shows the band, preset number and station frequency memorized.

- *A total of 18 stations can be stored in the preset memory (12-FM, 6-AM).*
- *If you store a station in a preset memory which already has a station, the current station will be cleared and replaced with the new station.*

Presetting Stations Automatically

1 Press **TUNER/SOURCE** repeatedly until the desired radio band is displayed.

2 Press and hold **TUNE/A.ME** for at least 2 seconds.
The tuner automatically seeks and stores the strongest available stations in the selected band (12-FM, 6-AM). They will be stored to preset memory in order of signal strength (For FM P1 to P12, for AM P1 to P6).
When the automatic memory has been completed, the tuner goes to the station stored in preset location No.1.

- *If no stations are stored, the tuner will return to the original station you were listening to before the auto memory procedure began.*

Tuning to Preset Stations

1 Press **TUNER/SOURCE** repeatedly until the desired band is displayed.

2 Press and hold **PRESET** for at least 2 seconds.
The Preset screen is displayed.

3 Turn the **Rotary encoder** to select a radio station.

4 Press **Q/ENTER**.
The display shows the band, preset number and frequency of the station selected.

- *You can also call up the desired preset memory by pressing **PRESET** repeatedly.*

Frequency Search Function

You can search for a radio station by its frequency.

1 Press **Q/ENTER** in Radio mode to activate Frequency search mode.

2 Turn the **Rotary encoder** to select the desired frequency.

3* Press **Q/ENTER** to receive the selected frequency.

* *Operation is not required during HD Radio reception.*

- *Press **↵** in the search mode to cancel. Or, the search mode will be canceled if no operation is performed for 10 seconds.*

Receiving a Multicast Station (HD Radio™ mode only)

Multicasting is the Ability to broadcast multiple program streams over a single FM frequency. This increases the amount and diversity of content choices. A maximum of eight multicast station channels can be selected on this unit.

- 1 Press **FUNC./SETUP** to select **MULTICAST**, the program number is displayed, and  indicator lights up.

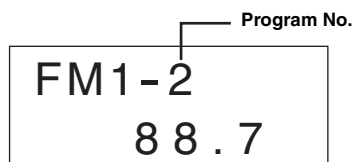

- 2 Press **VIEW Q/ENTER** to display the Program Type screen for 2 seconds.
- 3 Turn the **Rotary encoder** to select a program, and press **VIEW Q/ENTER**.
The selected program is received.

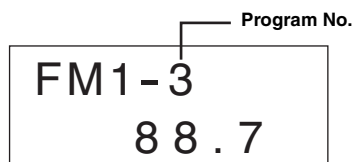

Program Service example:

Multicast Radio Station	Program No.	Program Service
88.7	1	MPS: Main Program Service
88.7	2	SPS: Sub-program Service
88.7	3	SPS: Sub-program Service
.	.	.
.	.	.
88.7	8	SPS: Sub-program Service

Changing the Display (HD Radio mode only)

Press VIEW.

Every time **VIEW** is pressed changes the display.

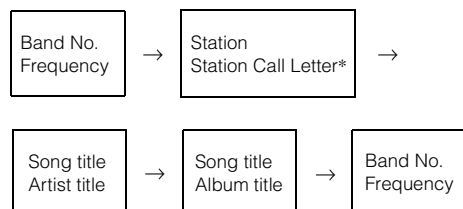

* You can set a long or short HD Radio station name. Refer to "HD Radio Station Call Setting" (page 27).

CD/MP3/WMA/AAC

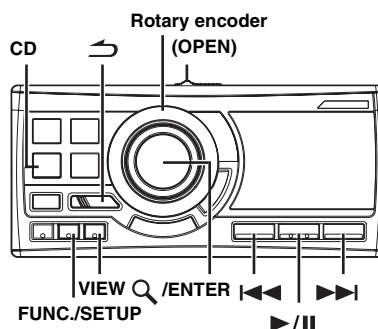

Playback

- 1 **Slide (OPEN).**
The front panel will open.
- 2 **Insert a disc with the label side facing up.**
The disc will be pulled into the unit automatically.

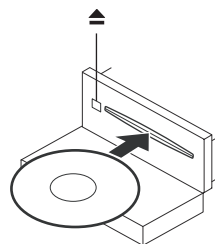

- When a disc is already inserted, press **CD** switch to the **DISC** player mode.
- 3 **Press <|<< or >>>| to select the desired track (file).**
Pressing and holding <|<< or >>>| will fast backward/fast forward track continuously.
 - 4 **To pause playback, press >|/||.**
Pressing >|/|| again will resume playback.
 - 5 **After sliding (OPEN) to open the front panel, press <^ to eject the disc.**

- Do not remove a CD during its eject cycle. Do not load more than one disc at a time. A malfunction may result from doing either.
- The “” indicator lights up when a disc is inserted.
- Three-inch (8 cm) CDs cannot be used.
- WMA format files that are protected by DRM (Digital Rights Management), AAC format files that have been purchased from iTunes Store and files that are copy-protected (copyright protection) cannot be played back on this unit.
- The track display for MP3/WMA/AAC data playback is the file numbers recorded on the disc.
- The playback time may not be correctly displayed when a VBR (Variable Bit Rate) recorded file is played back.
- Press **VIEW** to switch the display. See “Changing the Display” (page 12) for information about display switching.

Repeat Play

1 Press **FUNC./SETUP**.

2 Press **Q/ENTER**.

The repeat mode is activated.

3 Turn the **Rotary encoder** to select the **Repeat playback mode**.

REPEAT ONE  : Only a track/file is repeatedly played back.

FOLDER ^{*1}  : Only files in a folder are repeatedly played back.

DISC ^{*2}  : A disc is repeatedly played back.

OFF : Repeat mode is turned off.

^{*1} MP3/WMA/AAC mode only.

^{*2} When an MP3 compatible CD changer is connected.

- If REPEAT DISC is set to ON during M I X ONE play in MP3 compatible CD changer mode, M.I.X. will apply to the current disc only.

4 Press **Q/ENTER**.

5 Press **FUNC./SETUP**.

The track (file) will be played repeatedly.

- If no operation is performed for 60 seconds, the unit returns to normal mode.
- To cancel, select OFF in the above procedure.

M.I.X. (Random Play)



1 Press **FUNC./SETUP**.

2 Turn the **Rotary encoder** to select **M I X**.

3 Press **Q/ENTER**.

The M.I.X. mode is activated.

4 Turn the **Rotary encoder** to select the **M I X playback mode**.

M I X ONE		: All tracks/files in a disc are played back in random sequence.
FOLDER ^{*1}		: Only files in a folder are played back in random sequence.
ALL ^{*2/*3}		: All the tracks on all the CDs in the current magazine will be played back in random sequence.
OFF		: M.I.X. mode is turned off.

^{*1} MP3/WMA/AAC mode only.

^{*2} When a CD changer equipped with the ALL M.I.X. function is connected.

^{*3} In the USB AUDIO mode, all files stored in the USB memory are played back in random sequence, and the “” indicator lights up.

- When a song is played back during Random (M.I.X.) play in the USB AUDIO mode, the song can be played back again randomly even if not all songs on the USB Memory have been played back.
- If M I X ONE is set to ON during REPEAT DISC play in CD changer mode, M.I.X. will apply to the current disc only.

5 Press **Q/ENTER**.

6 Press **FUNC./SETUP**.

The tracks (files) will be played back in random sequence.

- If no operation is performed for 60 seconds, the unit returns to normal mode.
- To cancel, select OFF in the above procedure.

Searching for CD Text

On discs utilizing CD Text, songs can be searched and played by using their recorded titles. For discs without CD Text, searches are made using the track numbers associated with each song.

1 Press **Q/ENTER** during play.

This will set the search mode.

2 Turn the **Rotary encoder** to select the **desired track**, and then press **Q/ENTER**.

This will play the selected track.

- Press  in the search mode to cancel. Or, the search mode is canceled if no operation is performed for 60 seconds.
- When CD Text Search is made during M.I.X. play, the M.I.X. play mode will be canceled.

File/Folder Name Search (Concerning MP3/WMA/AAC)

Folder and file names may be searched and displayed during playback.

- 1 During MP3/WMA/AAC playback, press **Q/ENTER** to activate the search mode.
- 2 Turn the **Rotary encoder** to select **Folder Name Search mode** or **File Name Search mode**, and then press **Q/ENTER**.

Folder Name Search mode

- 3 Turn the **Rotary encoder** to select the desired folder.
- 4 Press and hold **Q/ENTER** for at least 2 seconds to play back the first file in the selected folder.

- Press and hold **↵** for at least 2 seconds in the search mode to cancel. Or, the search mode is canceled if no operation is performed for 60 seconds.
- To search for files in the Folder Name Search mode, press **Q/ENTER**. Files in the folder may be searched.
- Press **↵** to exit Folder Name Search mode in step 3 in order to select File Name Search mode.
- The root folder is displayed as "ROOT".
- When Folder Name Search is made during M.I.X. play, the M.I.X. play mode will be canceled.

File Name Search mode

- 3 Turn the **Rotary encoder** to select the desired file.
- 4 Press **Q/ENTER** to play back the selected file.

- Press and hold **↵** for at least 2 seconds in the search mode to cancel. Or, the search mode is canceled if no operation is performed for 60 seconds.
- Press **↵** in the search mode to return to the previous mode.
- When File Name Search is made during M.I.X. play, the M.I.X. play mode will be canceled.

Quick Search

You can search for tracks (files).

- 1 Press and hold **Q/ENTER** for at least 2 seconds to activate Quick Search mode.
- 2 Turn the **Rotary encoder** to select a desired track (file).

The selected track is played back immediately.

- Before using Quick Search function, set Quick Search to "ON" (MP3/WMA/AAC only). Refer to "Setting the Quick Search ON and OFF" (page 8).
- Press **↵** in the search mode to cancel. Or, the search mode is canceled if no operation is performed for 10 seconds.

Select the desired Folder (Folder up/down) (MP3/WMA/AAC)

- 1 Press and hold **Q/ENTER** for at least 2 seconds to activate the Folder up/down mode.
- 2 Turn the **Rotary encoder** to select the desired folder.
Turning to the right will advance to the next folder.
Turning to the left will return to the previous folder.
The first file in the selected folder is played back.

- This function is effective only when Quick Search is OFF, refer to "Setting the Quick Search ON and OFF" (page 8).

Changing the Display

Press **VIEW**.

CD mode:

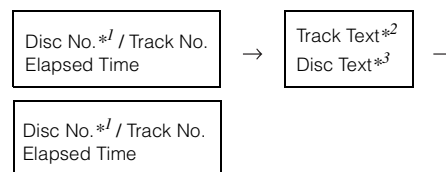

MP3/WMA/AAC mode:

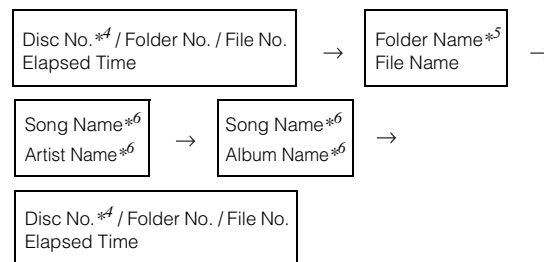

*1 Displayed only in the CD changer mode.

*2 "T TEXT" is displayed if there is no Track Text.

*3 "D TEXT" is displayed if there is no Disc Text.

*4 Displayed only in the MP3 changer mode.

*5 The root folder is displayed as "ROOT".

*6 TAG information

"ARTIST"/"ALBUM"/"SONG" is displayed if there is no tag information.

- Only alphanumeric characters can be displayed.
- Some characters may not be correctly displayed.
- "NO SUPPORT" is displayed when text information is not compatible with this unit.

About MP3/WMA/AAC

CAUTION

Except for private use, duplicating audio data (including MP3/WMA/AAC data) or distributing, transferring, or copying it, whether for free or for a fee, without permission of the copyright holder is strictly prohibited by the Copyright Act and by international treaty.

What is MP3?

MP3, whose official name is "MPEG-1 Audio Layer 3," is a compression standard prescribed by the ISO, the International Standardization Organization and MPEG which is a joint activity institution of the IEC.

MP3 files contain compressed audio data. MP3 encoding is capable of compressing audio data at extremely high ratios, reducing the size of music files to as much as one-tenth their original size. This is achieved while still maintaining near CD quality. The MP3 format realizes such high compression ratios by eliminating the sounds that are either inaudible to the human ear or masked by other sounds.

What is AAC?

AAC is the abbreviation for "Advanced Audio Coding", and is a basic format of audio compression used by MPEG2 or MPEG4.

What is WMA?

WMA, or "Windows Media™ Audio," is compressed audio data. WMA is similar to MP3 audio data and can achieve CD quality sound with small file sizes.

Method for creating MP3/WMA/AAC files

Audio data is compressed using software with MP3/WMA/AAC codecs. For details on creating MP3/WMA/AAC files, refer to the user's manual for that software.

MP3/WMA/AAC files that are playable on this device have the file extensions.

MP3: "mp3"

WMA: "wma" (ver. 7.1, 8 and 9 are supported)

AAC: "m4a"

There are many different versions of the AAC format. Confirm that the software being used conforms to the acceptable formats listed above. It's possible that the format may be unplayable even though the extension is valid.

Playback of AAC files encoded by iTunes is supported.

Supported playback sampling rates and bit rates

MP3

Sampling rates: 48 kHz, 44.1 kHz, 32 kHz, 24 kHz, 22.05 kHz, 16 kHz, 12 kHz, 11.025 kHz, 8 kHz

Bit rates: 8 - 320 kbps

WMA

Sampling rates: 48 kHz, 44.1 kHz, 32 kHz

Bit rates: 48 - 192 kbps

AAC

Sampling rates: 48 kHz, 44.1 kHz, 32 kHz, 24 kHz, 22.05 kHz, 16 kHz, 12 kHz, 11.025 kHz, 8 kHz

Bit rates: 16 - 320 kbps

This device may not play back correctly depending on sampling rates.

In the USB AUDIO mode, the playback time may not be correctly displayed when a VBR (Variable Bit Rate) recorded file is played back.

ID3 tags/WMA tags

This device supports ID3 tag v1 and v2, and WMA tag.

If tag data is in an MP3/WMA/AAC file, this device can display the title (track title), artist name, and album name ID3 tag/WMA tag data.

This device can only display single-byte alphanumeric characters (up to 30 for ID3 tags and up to 15 for WMA tags) and the underscore. For non-supported characters, the display is NO SUPPORT.

If information contains characters other than ID3 tag information, the audio file may not be played back.

The tag information may not be correctly displayed, depending on the contents.

Playing back MP3/WMA/AAC

MP3/WMA/AAC files are prepared, then written to a CD-R, CD-RW using CD-R writing software or stored to a USB memory. A disc can hold up to 510 files/folders (including Root Folders), and the maximum number of folders is 255. This unit can recognize at least 100 folders (including root folder) and 100 files per folder stored in USB memory.

Playback may not be performed if a disc or USB memory exceeds the limitations described above.

Do not make a file's playback time more than 1 hour.

Media supported

The media that this device can play back are CD-ROMs, CD-Rs, and CD-RWs.

This device also can play back USB memory media.

Corresponding File Systems

This device supports discs formatted with ISO9660 Level 1 or Level 2.

Under the ISO9660 standard, there are some restrictions to remember.

The maximum nested folder depth is 8 (including the root directory). The number of characters for a folder/file name is limited.

Valid characters for folder/file names are letters A-Z (all caps), numbers 0-9, and '_' (underscore).

This device also can play back discs in Joliet, Romeo, etc., and other standards that conform to ISO9660. However, sometimes the file names, folder names, etc., are not displayed correctly. This device also supports FAT 12/16/32 for USB memory device.

Formats supported

This device supports CD-ROM XA, Mixed Mode CD, Enhanced CD (CD-Extra) and Multi-Session.

This device cannot correctly play back discs recorded with Track At Once or packet writing.

Order of files

Files are played back in the order that the writing software writes them to the disc. Therefore, the playback order may not be what is expected. Verify the writing order in the software's documentation. The playback order of the folders and files is as follows.

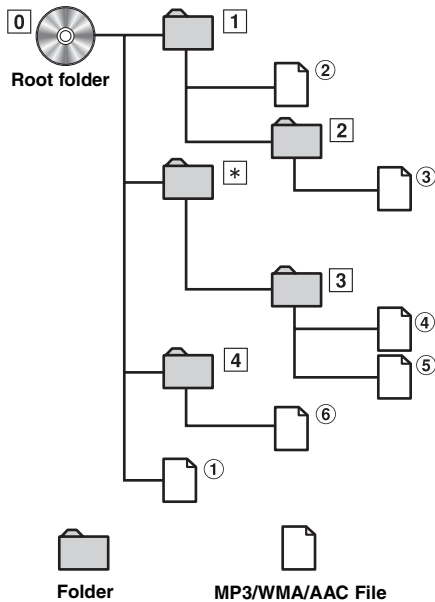

* The folder No./ folder Name will not be displayed if no file is contained in the folder.

Terminology

Bit rate

This is the "sound" compression rate specified for encoding. The higher the bit rate, the higher the sound quality, but also the larger the files.

Sampling rate

This value shows how many times per second the data is sampled (recorded). For example, music CDs use a sampling rate of 44.1 kHz, so the sound is sampled (recorded) 44,100 times per second. The higher the sampling rate, the higher the sound quality, but also the larger the volume of data.

Encoding

Converting music CDs, WAVE (AIFF) files, and other sound files into the specified audio compression format.

Tag

Song information such as track titles, artist names, album names, etc., written into MP3/WMA/AAC files.

Root folder

The root folder (or root directory) is found at the top of the file system. The root folder contains all folders and files. It is created automatically for all burned discs.

iPhone/iPod (Optional)

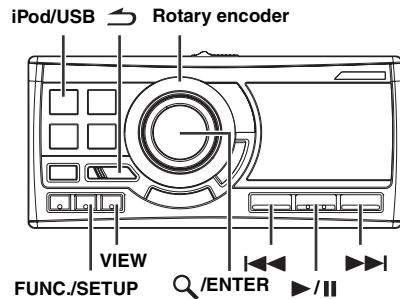

An iPhone/iPod can be connected to this unit by using the Interface cable for iPod (supplied). When this unit is connected by using the cable, the controls on the iPod are not functional.

- Internet and telephone functions of iPod touch or iPhone, etc., can also be used when connecting to the unit. However, using these functions will stop or pause the song playing. To avoid a possible malfunction, do not operate the head unit during this time.
- If you connect an iPhone to this unit, it can be used as an iPod. If you use iPhone as a hands-free phone, you need the optional BLUETOOTH INTERFACE (KCE-400BT).

iPhone/iPod models usable with this unit

- Confirmed devices regarding Made for iPod. Correct function of earlier versions cannot be guaranteed.

iPod touch (2nd generation): Ver.3.0
iPod nano (4th generation): Ver.1.0.2
iPod classic (120GB only): Ver.2.0.1
iPod touch (1st generation): Ver.3.0
iPod nano (3rd generation): Ver.1.1.3 PC
iPod classic (80GB, 160GB only): Ver.1.1.2 PC
iPod nano (2nd generation): Ver.1.1.3
iPod with video: Ver.1.3
iPod nano (1st generation): Ver.1.3.1

Confirmed devices regarding Works with iPhone. Correct function of earlier versions cannot be guaranteed.

iPhone 3GS: Ver.3.1
iPhone 3G: Ver.3.0
iPhone: Ver.3.0

- For clarity in identifying your model of iPod, please see Apple's own document "Identifying iPod models" at <http://support.apple.com/kb/HT1353>
- This unit does not support video playback from iPhone/iPod, even using a video-compatible cable.

Playback

- 1 Press **iPod/USB** to switch to the **USB IPOD** mode.
 - 2 Press **◀◀** or **▶▶** to select the desired song.
Pressing and holding **◀◀** or **▶▶** will fast backward/fast forward the current song.
 - 3 To pause playback, press **▶/||**.
Pressing **▶/||** again will resume playback.
- If a song is playing on the iPhone/iPod when it is connected to this unit, it will continue playing after the connection.
 - An episode or audiobook may have several chapters, the chapter can be changed by pressing **◀◀** or **▶▶**.
 - When an iPhone 3GS or an iPod (Ver.3.x) is connected to this unit, after changing the source or received traffic information, etc., to return to USB iPod mode, "NO USB DEVICE" may be displayed. In this case, reconnect the iPhone 3GS/iPod.

Searching for a desired Song

An iPhone/iPod can contain hundreds of songs. By keeping these songs organized in playlists, this unit can use these to ease song searches.

Using the Playlist/Artist/Album/Podcast/Audiobook/Genre/Composer/Song search mode's individual hierarchy, you can narrow down your search as shown in the table below.

Hierarchy 1	Hierarchy 2	Hierarchy 3	Hierarchy 4
PLAYLISTS	SONG	—	—
ARTISTS*	ALBUM*	SONG	—
ALBUMS*	SONG	—	—
SONGS	—	—	—
PODCASTS	EPISODE	—	—
GENRES*	ARTIST*	ALBUM*	SONG
COMPOSERS*	ALBUM*	SONG	—
AUDIOBOOKS	—	—	—

- You can select your preferred search mode. Refer to "iPod Search Mode Setting" (page 26).

For example: Searching by Artist name

The following example explains how an ARTISTS search is performed. Another search mode can be used for the same operation, although the hierarchy differs.



- 1 Press **Q/ENTER** to activate the **Menu Select** mode.
 - 2 Turn the **Rotary encoder** to select the **ARTISTS**, and then press **Q/ENTER**.
The artist search mode is activated and artists names are displayed.
 - 3 Turn the **Rotary encoder** to select the desired **Artist**, and then press **Q/ENTER**.
The album search mode is activated and albums names are displayed.
 - 4 Turn the **Rotary encoder** to select an album, and then press **Q/ENTER**.
The song search mode is activated and songs names are displayed.
 - 5 Turn the **Rotary encoder** to select a song and press **Q/ENTER**.
The selected song is played back.
- While in the search mode, if you press and hold **↶** for at least 2 seconds the search mode is canceled.
 - In the search mode, pressing **↶** will return to the previous mode.
 - When search is made during M.I.X. play, the M.I.X. play mode will be canceled.
 - "NO SONG" will be displayed if there are no songs in the selected playlist in the PLAYLISTS search mode.
 - "NO PODCAST" will be displayed if there is no podcast data in the iPhone/iPod in the PODCASTS search mode.
 - "NO A-BOOK" will be displayed if there is no audiobook data in the iPhone/iPod in AUDIOBOOKS search mode.
 - If "iPod name" stored in the iPhone/iPod is selected in the desired playlist search mode and **Q/ENTER** is pressed, you can search for all songs in the iPhone/iPod. Also, if you press and hold **Q/ENTER** for at least 2 seconds, all songs in the iPhone/iPod are played back.
 - The display "NO SUPPORT" is scrolled if text information is not compatible with this unit.
 - After selecting [ALL] in the search mode with "*", press and hold **Q/ENTER** for at least 2 seconds to play back all songs in the iPhone/iPod or selected search mode.
 - If percent skip function is activated in the search mode, a search can be made quickly by skipping to the specified location. For details, refer to "Percent Skip Function" on page 16.
 - If Alphabet Skip Function is activated in the search mode, a search can be made quickly by Alphabet skip function to find the desired artist or song, etc. For details, refer to "Random Play Shuffle (M.I.X.)" on page 17.
 - If no operation is performed for 60 seconds, the unit will return to normal mode automatically.

Quick Search

You can search a song from all songs in the iPhone/iPod without selecting an album, artist, etc.

1 Press and hold /ENTER for at least 2 seconds to activate the Quick Search mode.

2 Turn the Rotary encoder to select a desired song.
The selected song is played back immediately.

- This function is effective only when Quick Search is ON, refer to “Setting the Quick Search ON and OFF” (page 8).
- While in the search mode, if you press , or no operation is performed for 10 seconds, the search mode is canceled.
- If many songs are in iPhone/iPod, it takes time to search for songs.
- This function is inactive during repeat () playback.

Percent Skip Function

The unit is provided with a percent skip function for effective searching. In Playlist/Artist/Album/Podcast/Audiobook/Genre/Composer/Song mode, you can quickly target any song. If there are 100 songs in your iPhone/iPod, they are divided into 10 groups using percentages (shown below).

Number of song %	All 100 songs							
	10th song	20th song	...	50th song	...	80th song	...	100th song
10 %								
20 %								
⋮								
50 %								
⋮								
80 %								
⋮								
100 %								

* You can select to show a percentage of the total stored songs, in 10% steps.

1 In the search mode, press FUNC./SETUP repeatedly to choose the percent skip mode.

Alphabet skip function → Percent skip function → Normal search mode → Alphabet skip function

2 Turn the Rotary encoder, and then press  or .

Each press of the  to the right will jump 10%, 20% and 100% in ascending order.

Each press of the  to the left will jump 100%, 90% and 10% in descending order.

- When the total number of list is less than 10, it will be skipped one by one.

Alphabet Skip Function

The default skip mode is alphabetic. Use this function to skip to the next number, symbol or letter (for example from A to B, B to C).



You can skip in reverse order such as B to A by pressing .

1 In the search mode, press FUNC./SETUP to alphabet skip mode.

Alphabet skip function → Percent skip function → Normal search mode → Alphabet skip function

2 Turn the Rotary encoder and then press  or .

A list is skipped to the next page or next number, symbol or letter.

- If the  or  is pressed and held, the display continuously changes.
- Titles are listed alphabetically, and can be skipped every 200 titles. If there are fewer than 200 titles, titles beginning with the next alphabetical character are selected.

Up/Down Function

If you select an album and press and hold /ENTER in the search mode, this album will be played back repeatedly. To go to the previous or next Album, use the Up/Down function.

1 Press and hold /ENTER for at least 2 seconds to activate the Direct Up/Down mode.

2 Turn the Rotary encoder to select the desired Playlist/Artist/Album/Genre/Composer.

- This function is effective only when Quick Search is OFF, refer to “Setting the Quick Search ON and OFF” (page 8).
- If the song search mode was used to select a song, this function is inactive.
- If an album is selected during an artist search, the Up/Down function can be used to play other albums by that artist.
- If you listen to an episode from a selected podcast or audiobook, the episode can be changed by this operation.
- This function is inactive during shuffle () playback.
- This function is available in USB AUDIO mode.

Search Position Memory

During iPhone/iPod playback, you can quickly return to the last-selected hierarchy level in the search mode.

1 Press .

The hierarchy you selected last in the search mode is displayed.

Random Play Shuffle (M.I.X.)

- 1 Press **FUNC./SETUP**.
- 2 Turn the **Rotary encoder** to select **M I X**, and press **Q/ENTER**.

The Shuffle mode is activated.

- 3 Turn the **Rotary encoder** to select the **M I X (Shuffle) playback mode**, and press **Q/ENTER**.

M I X ALBUM  : An album in the iPhone/iPod is selected at random, and is played back in the album song order.

SONG  : If you select a song in the search mode, all songs in the selected mode are played back at random.

OFF : Shuffle mode off.

- 4 Press **FUNC./SETUP**.
The songs will be played back in random sequence.

- If no operation is performed for 60 seconds, the unit will return to normal mode.
- To cancel, select **OFF** in the above procedure.
- *Shuffle Album/Shuffle Song works the same way as iPhone/iPod Shuffle Albums/Shuffle Songs.*

Random Play Shuffle All

Shuffle ALL plays all songs in the iPhone/iPod randomly.

- 1 Press **Q/ENTER**.
The Menu Select screen is displayed.
- 2 Press **Q/ENTER** while selecting **SHUFFLE ALL**.
The indicator  lights, and the songs will be played back in random sequence.

- To cancel, set the Shuffle mode to **OFF**. Refer to “Repeat Play” (page 17).
- If **SHUFFLE ALL** is selected, the selected ones which are being played back in the search mode are canceled.

Repeat Play

- 1 Press **FUNC./SETUP**.
The Function screen is displayed.
- 2 Press **Q/ENTER**.
The Repeat mode is activated.
- 3 Turn the **Rotary encoder** to select **REPEAT SONG**, and press **Q/ENTER**.

REPEAT SONG  : A single song is repeatedly played back.

OFF : Repeat mode off.

- 4 Press **FUNC./SETUP**.
The song is repeatedly played back.

- If no operation is performed for 60 seconds, the unit returns to normal mode.
- To cancel, select **OFF** in the above procedure.
- Depending on the connected iPod, track up/down may be not available during Repeat play.

Changing the Display

Press **VIEW**.

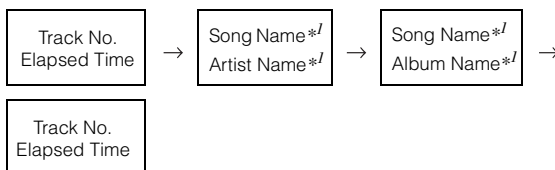

*1 TAG information

“ARTIST”/“ALBUM”/“SONG” is displayed if there is no tag information.

- Only alphanumeric characters can be displayed.
- The maximum number of characters is 70 (70 byte).
- Some characters may not be correctly displayed.
- “NO SUPPORT” is displayed when text information is not compatible with this unit.

USB memory (Optional)

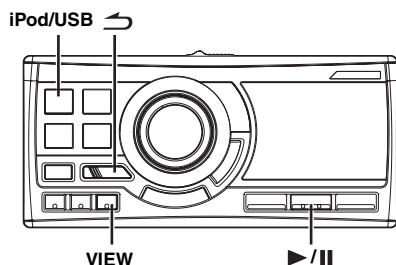

Controlling USB memory (Optional)

A USB memory device may be connected to this unit. With a USB memory device connected to this unit, the audio files will be playable from this unit.

- The controls on this unit for USB memory operation are operative only when a USB memory is connected.

Playing MP3/WMA/AAC Files with the USB memory (Optional)

If you connect a USB memory device containing MP3/WMA/AAC, these files are playable on this unit.

1 Press iPod/USB to switch to the USB AUDIO mode.

2 To pause playback, press ▶/||.

Pressing ▶/|| again will resume the playback.

- The root folder is displayed as "ROOT" in the Folder Name Search mode.
- This unit plays back files in the USB memory with the same controls and modes as playback of CDs containing MP3/WMA/AAC. For details, refer to "CD/MP3/WMA/AAC" on page 10 to 14.
- Before disconnecting USB memory, be sure to change to another source or set to pause.
- The playback time may not be correctly displayed when a VBR (Variable Bit Rate) recorded file is played back.

Search Position Memory

During USB playback, you can quickly return to the last-selected hierarchy level in the search mode.

1 Press ↶.

The hierarchy you selected last in the search mode is displayed.

Hands-Free Phone Operation

About the Hands-Free Phone

Hands-free calls are possible when using a HSP (Head Set Profile) and HFP (Hands-Free Profile) compatible mobile phone with a ALPINE BLUETOOTH INTERFACE (KCE-400BT).

For detailed setting of BLUETOOTH, refer to the Owner's Manual of the optional BLUETOOTH INTERFACE (KCE-400BT).

- If both calling parties are using hands-free devices, or the call is made in a noisy location, difficulty hearing the other person's voice is normal.
- Depending on telephone line conditions or certain mobile devices used, voices may sound unnatural.
- When using a microphone, speak as directly as you can into the microphone to pick up the best sound quality.
- Certain mobile phone features are dependent on the capabilities and settings of your service provider's network. Additionally, certain features may not be activated by your service provider, and/or the provider's network settings may limit the feature's functionality. Always contact your service provider about feature availability and functionality.

All features, functionality, and other product specifications, as well as the information contained in the Owner's Manual are based upon the latest available information and are believed to be accurate at the time of printing.

Alpine reserves the right to change or modify any information or specifications without notice or obligation.

Answering a Call

Incoming calls are announced by the received call ring tone and a displayed message (Caller name/PHONE No.).

Press any button to answer a call.

- When "Answering Calls Automatically" is set to ON for KCE-400BT, you can receive a call automatically.
- When making a call, audio from the current source is muted.

Hanging up the Telephone

Press and hold ↵ for at least 2 seconds to hang up the telephone.

Adjusting the volume when receiving a Call

During a call, the voice level is adjustable. This adjusted volume is stored for future calls.

Turn the Rotary encoder to adjust the volume.

- When adjusting the call volume be aware that increasing the volume excessively may result in feedback. If feedback is noticed during the phone conversation, turn down the volume as low as possible until the feedback is eliminated or at an acceptable level. Positioning the microphone away from the main boat speakers may also reduce feedback at higher volumes.

Redial Function

You can redial the person you have previously called.

After finishing a call, press **FUNC./SETUP** within 5 seconds.

The telephone is redialed.

Audio Switching Operation

While making a call, this function allows you to initiate the transfer of the audio between the mobile phone and speakers.

While calling, press and hold **Q/ENTER** for at least 2 seconds to switch the call sound between the speakers and mobile phone.

- Depending on the mobile phone, this operation may not be performed.

Call History

Call History is recorded for the last dialed/received/missed calls. There are various ways of making calls based on the "Call History." The following steps 1 to 3 are common to the various ways of making these calls. The following step 4 to step 6 is invalid to the VOICE DIAL function. For details, refer to each individual category for making calls.

1 Press **FUNC./SETUP**.

2 Turn the Rotary encoder to select the HFT, and then press **Q/ENTER**.

The outgoing method list is displayed.

3 Turn the Rotary encoder to select the outgoing mode.

Setting items : DIALED / RECEIVED / MISSED / PHONE BOOK / VOICE DIAL*¹

DIALED : Dialed history

RECEIVED : Received history

MISSED : Missed incoming history

PHONE BOOK : Mobile phonebook

VOICE DIAL : Voice dial operation

*¹ In the BT AUDIO mode, VOICE DIAL will not be displayed.

- The adapter will update the information in the Call History automatically each time a mobile phone is connected or receiving/dialing a call. At this time, if you select any outgoing mode, "UPDATING" will be displayed.

4 Press **Q/ENTER**.

The outgoing mode is activated, and each mode list is displayed.

- It may take some time for the list to be displayed, and also directly after connection, the list may not be brought up to date.

5 Turn the Rotary encoder to select a name or a telephone number from the list.

6 Press **Q/ENTER**.

The selected telephone will be called.

If one name has several numbers registered in the telephone book, press **Q/ENTER** after selecting the name*², then turn the Rotary encoder to choose the desired number and press **Q/ENTER**, the telephone will be called. Press and hold **Q/ENTER** for at least 2 seconds after selecting the name, the default number of the name will be called. Depending on the connected mobile phone, this function may not be performed.

*² If the name cannot be recognized, default number will be displayed.

- If you place a call directly from the paired mobile phone, the phone number is not displayed, you cannot redial from the unit in this case.

Redialing a Number in Dialed Calls History

Previously dialed telephone numbers are stored in dialed calls history. You can redial a number by searching from dialed calls history.

Setting item: DIALED

Dialing a Number in Received Calls History

Telephone numbers from received calls are stored in the received calls history. You can redial these numbers by searching here.

Setting item: RECEIVED

Dialing a Number in Missed Calls History

Telephone numbers for received calls that are missed are stored in the missed calls history. You can redial these numbers by searching here.

Setting item: MISSED

Dialing a Number In the Phone Book (PHONE BOOK)

Up to 5,000 telephone numbers are downloadable to the BLUETOOTH compatible unit from a mobile phone. Dial a call by selecting a person from the phone book list.

Setting item: PHONE BOOK

- If a name cannot be obtained via the phone book, only the "-----" is displayed for 2 seconds.
- The names registered in the telephone book are displayed. If the name is not registered, a number is displayed. If both name and number cannot be displayed, "ID UNSENT" will be displayed.
- The names of PHONE BOOK are listed alphabetically with the same beginning alphabetical character, and can be skipped to the next alphabetical character by pressing ◀◀ or ▶▶. e.g. press ▶▶ to the section beginning with alphabet B from A.
- The order of the list display depends on the design of the mobile phone.
- If the call history or phonebook of the mobile phone is added or deleted while it is connected to the unit, the list displayed on the unit may not be brought up to date. If it is not updated, you cannot correctly place a call.

Voice Dial Operation (VOICE DIAL)

You can call the telephone by performing voice operation after selecting VOICE DIAL in step 3.

1 Press Q/ENTER.

The speak mode is activated, and "SPEAK PLEASE" is displayed.

2 Say the telephone number, name you want to call into the microphone.

Pressing and holding ↻ for at least 2 seconds will cancel the voice dial mode.

- If the voice dial fails, the unit will return to normal mode in 60 seconds.
- You can perform this operation only when a voice dial compatible mobile phone is connected. If the mobile phone is not compatible with the voice dial, "NO SUPPORT" is displayed for 2 seconds.
- The Voice Dial function performance depends on the recognition range of the mobile phone and mounting location of the microphone. Note when the microphone is mounted.
- This operation cannot be performed when the current source is BT AUDIO.
- If a called person that you say is not found, "NO CALL" is displayed for 2 seconds.
- Voice dial operation depends on the function of the mobile phone. For details, refer to the Owner's Manual of the mobile phone.
- If you place a call via voice dial, you cannot display a phone number or name.

Sound Setting

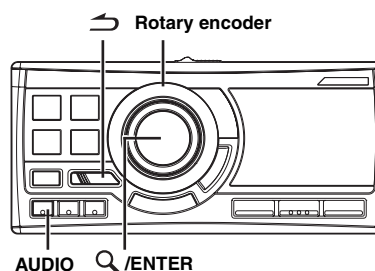

Adjusting Subwoofer/Bass/Treble/Balance (Between Left and Right)/Fader (Between Front and Rear)/Loudness/Defeat

1 Press **AUDIO** repeatedly to choose the desired mode.

Each press changes the mode as follows:

SUBW LV*¹ → BASS LV*⁴ → TREBLE LV*⁴ →
BALANCE LV*² → FADER LV*^{2/3} → LOUD*⁴ → DEFEAT →
ZONE1/ZONE2*⁵ → SUBW LV*¹

Subwoofer: +0 ~ +15
Bass level: -7 ~ +7
Treble level: -7 ~ +7
Balance: -15 ~ +15
Fader: -15 ~ +15
Loudness: ON/OFF
Defeat: ON/OFF
ZONE1/ZONE2: 0 ~ 35

- If **AUDIO** is not pressed within 5 seconds after selecting the Subwoofer, Bass, Treble, Balance or Fader mode, the unit automatically returns to normal mode.
- Loudness introduces a special low-and high-frequency emphasis at low listening levels. This compensates for the ear's decreased sensitivity to bass and treble sound. The function is inoperable when DEFEAT is set to ON.
- When an external audio processor is connected, if the selected source (such as CD changer, etc.) via Ai-Net carried out, there will be no sound output from ZONE2.

*¹ When the subwoofer mode is set to OFF, its level cannot be adjusted.

*² BALANCE and FADER are effective only for ZONE1 (Front, Rear, Subwoofer).

*³ If you set the 4.2ch (FRONT/REAR/SUBW.)/2.2ch (3WAY) switch of the IMPRINT audio processor (PXA-H100) to 2.2ch (3WAY), you cannot adjust the FADER mode. For details, refer to the Owner's Manual of PXA-H100.

*⁴ When an external audio processor is connected, this setting cannot be made.

*⁵ Adjust the volume level of the selected (ZONE1/ZONE2/ALL). For volume mode setting, refer to "Multi-Zone Volume Control" (page 7).

2 Turn the **Rotary encoder** until the desired sound is obtained in each mode.

- Depending on the connected devices, some functions and display indications do not work.

Turning Subwoofer ON/OFF

When the subwoofer is on, you can adjust the subwoofer output level (refer to page 20).

For this unit, the following setting can be made only when the IMPRINT audio processor (PXA-H100) is not connected.

1 Press and hold AUDIO for at least 2 seconds to activate the AUDIO selection mode.

2 Turn the Rotary encoder to select the SUBW mode, and then press Q/ENTER.

SUBW ↔ SUBW SYSTEM^{*1} ↔ BASS ↔ TREBLE ↔ HPF ↔ SUBW

^{*1} Displayed only when subwoofer is ON.

3 Turn the Rotary encoder to select SUBW ON/OFF, and then press Q/ENTER.

ON ↔ OFF

4 Press ↵ to return to normal mode.

- If no operation is performed for 60 seconds, the unit will return to normal mode automatically.
- If ↵ is pressed during setting, the unit returns to the previous item.

Setting the Subwoofer System

When the subwoofer is on, you can select either SYS 1 or SYS 2 for the desired subwoofer effect.

For this unit, the following setting can be made only when the IMPRINT audio processor (PXA-H100) is not connected.

1 Press and hold AUDIO for at least 2 seconds to activate the AUDIO selection mode.

2 Turn the Rotary encoder to select the SUBW SYSTEM mode, and then press Q/ENTER.

SUBW ↔ SUBW SYSTEM^{*1} ↔ BASS ↔ TREBLE ↔ HPF ↔ SUBW

^{*1} Displayed only when subwoofer is ON.

3 Turn the Rotary encoder to select the SUBW SYS 1 or SUBW SYS 2, and then press Q/ENTER.

SYS 1 ↔ SYS 2

SYS 1 : Subwoofer level changes according to the main volume setting.

SYS 2 : Subwoofer level change is different from the main volume setting. For example, even at low volume settings, the subwoofer is still audible.

4 Press ↵ to return to normal mode.

- If no operation is performed for 60 seconds, the unit will return to normal mode automatically.
- If ↵ is pressed during setting, the unit returns to the previous item.
- This function is inoperable when Subwoofer is set to OFF.

Setting the Bass Control

You can change the Bass Frequency emphasis to create your own tonal preference.

For this unit, the following setting can be made only when the IMPRINT audio processor (PXA-H100) is not connected.

1 Press and hold AUDIO for at least 2 seconds to activate the AUDIO selection mode.

2 Turn the Rotary encoder to select the BASS Adjustment mode, and then press Q/ENTER.

SUBW ↔ SUBW SYSTEM^{*1} ↔ BASS ↔ TREBLE ↔ HPF ↔ SUBW

^{*1} Displayed only when subwoofer is ON.

Setting the Bass Level

3-1 *2 Turn the Rotary encoder to select the desired bass level (-7~+7), and then press Q/ENTER.

You can emphasize or weaken the bass level.

Setting the Bass Bandwidth

3-2 Turn the Rotary encoder to select the desired bass bandwidth, and then press Q/ENTER.



Changes the boosted bass bandwidth to wide or narrow. A wider setting will boost a wide range of frequencies above and below the center frequency. A narrower setting will boost only frequencies near the center frequency.

Setting the Bass Center Frequency

3-3 Turn the **Rotary encoder** to select the desired bass center frequency, and then press **Q/ENTER**.

60 (Hz) ↔ 80 (Hz) ↔ 100 (Hz) ↔ 120 (Hz) ↔ 60 (Hz)

Emphasizes the displayed bass frequency ranges.

4 Press **↵** to return to normal mode.

- If no operation is performed for 60 seconds, the unit will return to normal mode automatically.
- If **↵** is pressed during setting, the unit returns to the previous item.
- The function is inoperable when **DEFEAT** is set to **ON**.

^{*2} The adjustment can also be made by pressing **IMPRINT**. Refer to "Adjusting Subwoofer/Bass/Treble/Balance (Between Left and Right)/Fader (Between Front and Rear)/Loudness/Defeat" (page 20).

Setting the Treble Control

You can change the Treble Frequency emphasis to create your own tonal preference.

For this unit, the following setting can be made only when the **IMPRINT** audio processor (**PXA-H100**) is not connected.

1 Press and hold **AUDIO** for at least 2 seconds to activate the **AUDIO** selection mode.

2 Turn the **Rotary encoder** to select the **TREBLE** Adjustment mode, and then press **Q/ENTER**.

SUBW ↔ SUBW SYSTEM^{*1} ↔ BASS ↔ TREBLE ↔ HPF ↔ SUBW

^{*1} Displayed only when subwoofer is **ON**.

Setting the Treble Level

3-1^{*2} Turn the **Rotary encoder** to select the desired treble level (-7~+7), and then press **Q/ENTER**.

You can emphasize the treble level.

Setting the Treble Center Frequency

3-2 Turn the **Rotary encoder** to select the desired treble center frequency, and then press **Q/ENTER**.

10.0 kHz ↔ 12.5 kHz ↔ 15.0 kHz ↔ 17.5 kHz ↔ 10.0 kHz

Emphasizes the displayed treble frequency ranges.

4 Press **↵** to return to normal mode.

- If no operation is performed for 60 seconds, the unit will return to normal mode automatically.
- If **↵** is pressed during setting, the unit returns to the previous item.
- The function is inoperable when **DEFEAT** is set to **ON**.

^{*2} The adjustment can also be made by pressing **IMPRINT**. Refer to "Adjusting Subwoofer/Bass/Treble/Balance (Between Left and Right)/Fader (Between Front and Rear)/Loudness/Defeat" (page 20).

Adjusting the High Pass Filter

The High Pass Filter on this unit can be adjusted to suit your personal taste.

For this unit, the following setting can be made only when the **IMPRINT** audio processor (**PXA-H100**) is not connected.

1 Press and hold **AUDIO** for at least 2 seconds to activate the **AUDIO** selection mode.

2 Turn the **Rotary encoder** to select the **HPF** Adjustment mode, and then press **Q/ENTER**.

SUBW ↔ SUBW SYSTEM^{*1} ↔ BASS ↔ TREBLE ↔ HPF ↔ SUBW

^{*1} Displayed only when subwoofer is **ON**.

3 Turn the **Rotary encoder** to select the desired **HPF** frequency, and then press **Q/ENTER**.

OFF ↔ 60 (Hz) ↔ 80 (Hz) ↔ 100 (Hz)

4 Press **↵** to return to normal mode.

- If no operation is performed for 60 seconds, the unit will return to normal mode automatically.
- If **↵** is pressed during setting, the unit returns to the previous item.
- The function is inoperable when **DEFEAT** is set to **ON**.

SETUP

Use the SETUP menu to flexibly customize the unit to suit your own preferences and usage. Choose settings from GENERAL, DISPLAY, etc., to make the desired changes.

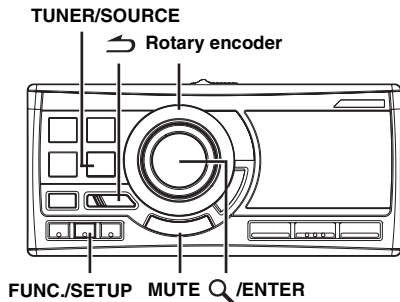

Follow steps 1 to 5 to choose an item to change. See the item descriptions following Step 5 for further details.

- 1 Press and hold **FUNC./SETUP** for at least 2 seconds to activate the **SETUP** selection mode.
- 2 Turn the **Rotary encoder** to select the desired item, and then press **Q/ENTER**.

BT*¹ ↔ AUDIO ↔ GENERAL ↔ DISPLAY ↔ IPOD ↔ XM/SIRIUS*² ↔ HD RADIO*³ ↔ BT*¹

*¹ Displayed only when **INT MUTE** is set to **OFF**, and the mode is set to other than **BT AUDIO**.

*² Only when **SAT Radio** receiver is connected.

*³ Only when **HD Radio** tuner module is connected.

- 3 Turn the **Rotary encoder** to select a setting item, and then press **Q/ENTER**.
(e.g. Select **POWER IC**)

BT:

BT IN

AUDIO*⁴:

AUX ZONE SELECT*⁵ ↔ MUTE LEVEL ↔ USER PRESET*⁶ ↔ MX*⁶ ↔ SUBW*⁶ ↔ MX LEVEL*⁷ ↔ AUX ZONE SELECT*⁵

GENERAL:

TUNER ↔ PLAY MODE ↔ BEEP ↔ INT MUTE*⁸ ↔ AUX+ ↔ AUX+ NAME*⁹ ↔ AUX ZONE ↔ AUX ZONE NAME*⁹ ↔ AUX ↔ AUX NAME*⁹ ↔ CHANGER NAME ↔ DIGITAL AUX ↔ D-AUX NAME*¹⁰ ↔ AUX IN GAIN*¹¹ ↔ POWER IC ↔ DEMO ↔ TUNER

DISPLAY:

VOL DISP ↔ ILLUMINATION ↔ DIMMER ↔ DIMMER LEVEL ↔ SCROLL TYPE ↔ TEXT SCROLL ↔ VOL DISP

IPOD:

PLAYLISTS ↔ ARTISTS ↔ ALBUMS ↔ SONGS ↔ PODCASTS ↔ GENRES ↔ COMPOSERS ↔ AUDIO BOOKS ↔ PLAYLISTS

XM:

XM ADF*¹²

SIRIUS:

CLEAR LOCK*¹² ↔ CLEAR SKIP*¹² ↔ SPORTS*¹² ↔ S-SEEK*¹² ↔ CLEAR LOCK*¹²

HD RADIO:

STATION CALL*¹³ ↔ DIGITAL SEEK*¹³ ↔ STATION CALL*¹³

*⁴ If **IMPRINT** audio processor is connected, you can make more detailed settings for the audio setting. For details, refer to "IMPRINT Operation (Optional)" (page 32).

*⁵ Displayed only when **AUX ZONE** is set to **ON**.

*⁶ Displayed only when an external audio processor is connected.

*⁷ Displayed only when **MX** is set to **ON** and an external audio processor is connected.

*⁸ Displayed only when **BT IN** is **OFF**.

*⁹ The setting can be made only when **AUX+/AUX ZONE/AUX** is set to **ON**.

*¹⁰ Displayed only when **DIGITAL AUX** is set to **ON**.

*¹¹ Displayed only when **AUX+** is set to **ON**.

*¹² Displayed only when **SAT** radio receiver is connected.

For the **SAT Radio** Setting, refer to "SAT Radio Receiver (Optional)" (page 28).

*¹³ Displayed only when **HD Radio TUNER MODULE (TUA-T500HD or TUA-T550HD)** is connected.

- 4 Turn the **Rotary encoder** to change the setting, and then press **Q/ENTER**

(e.g. Select **POWER IC ON** or **POWER IC OFF**.)

- 5 Press and hold **↶** for at least 2 seconds to return to normal mode.

- Pressing **↶** during the procedure will return to the previous mode.
- If no operation is performed for 60 seconds, the unit will return to normal mode automatically.

BLUETOOTH Setting

Select **BT** from the setup main menu in step 2 above.

Make this setting when the **BLUETOOTH INTERFACE (KCE-400BT)** is connected and the **BLUETOOTH** function is used. For details, refer to the Owner's Manual of the optional **BLUETOOTH INTERFACE (KCE-400BT)**.

Set **ADPT** when the **BLUETOOTH INTERFACE (KCE-400BT)** is connected.

If an optional **BLUETOOTH INTERFACE (KCE-400BT)** is connected, you can place a hands-free call by a **BLUETOOTH**-equipped mobile phone. For details, refer to "Hands-Free Phone Operation" (page 18).

- If the mobile phone compatible with the **Voice Dial** function is connected, the **Voice Dial** function can be used.
- When **INT MUTE** is set to **ON**, the **BLUETOOTH** setting cannot be made. When the **BLUETOOTH INTERFACE (KCE-400BT)** is connected, set **INT MUTE** to **OFF**. Refer to "Turning Mute Mode On/Off (INT MUTE)" (page 24).

Setting the BLUETOOTH Connection

BT IN ADPT / BT IN OFF (Initial setting)

Audio Setting

AUDIO is selected on the setup menu in step 2.

AUX Zone Select (AUX ZONE SELECT)

ALL (Initial setting) / ZONE1 / ZONE2

When AUX ZONE is ON, you can select the connected speaker to output the sound signal of AUX Zone.

- ALL : The sound is output from all Speakers.
- ZONE1 : The sound can only be output from the Boat Speakers.
- ZONE2 : The sound can only be output from the ZONE2 Speakers.

Setting the MUTE Level (MUTE LEVEL)

LV 1 / LV 2 (Initial setting) / LV 3 / LV 4 / LV 5 / LV 6

Set the amount of attenuation when muting is on.

- LV 1 : The sound is attenuated by 10 dB.
- LV 2 : The sound is attenuated by 20 dB.
- LV 3 : The sound is attenuated by 30 dB.
- LV 4 : The sound is attenuated by 40 dB.
- LV 5 : The sound is attenuated by 50 dB.
- LV 6 : The sound is attenuated by 60 dB.

Operating the External Audio Processor (USER PRESET)

PRE-1 (Initial setting) / PRE-2 / PRE-3 / PRE-4 / PRE-5 / PRE-6

Turn the **Rotary encoder** to select the desired preset number, and then press **Q/ENTER**.

- For the operation of external audio processor, refer to the Owner's Manual of the external audio processor you purchased.

Turning Media Xpander ON/OFF

OFF (Initial setting) / ON

When the Media Xpander is ON, and external audio processor is connected, you can adjust the Media Xpander level.

Setting the MX Level

NON EFFECT / LEVEL 1 / LEVEL 2 / LEVEL 3

MX (Media Xpander) makes vocals or instruments sound distinct regardless of the music source. The FM radio, CD, USB memory and iPhone/iPod, will be able to reproduce the music clearly. The initial setting is different depending on the source.

Subwoofer On and Off

SUBW ON (Initial setting) / SUBW OFF

The adjustment can also be made by pressing and holding **AUDIO*** for at least 2 seconds. Refer to "Turning Subwoofer ON/OFF" (page 21).

- * For this unit, when connecting **IMPRINT** audio processor, you can't turn the subwoofer ON or OFF by pressing **AUDIO**.

General Setting

GENERAL is selected on the setup main menu in step 2.

Setting TUNER mode (TUNER)

MODE1 (Initial setting) / MODE2

You can change the tuner frequency area.

- MODE1 : FM: 87.7~107.9 MHz; AM: 530~1710 KHz
- MODE2 : FM: 87.50~108.00 MHz; AM: 531~1602 KHz

Playing MP3/WMA/AAC Data (PLAY MODE)

CD-DA / CD-DA&MP3 (Initial setting)

This unit can play back CDs containing both CD and MP3/WMA/AAC data (created in Enhanced CD (CD Extra) format). However, in some situations, playback of an enhanced CD may be difficult. In this case, you can select playback of a single session only, containing the CD data. When a disc contains both CD and MP3/WMA/AAC data, playback starts from the CD data portion of the disc.

- CD-DA: Only the CD data in Session 1 can be played back.
- CD-DA&MP3: CD data, MP3/WMA/AAC files in mixed mode, and multi-session discs can be played back.

- Perform this setting before inserting a disc. If a disc has already been inserted, remove it first. (If you use an MP3 changer, you have to change discs.)

Sound (Beep) Guide Function

BEEP ON (Initial setting) / BEEP OFF

This function will give audible feedback with varying tones depending upon the button pressed.

Turning Mute Mode On/Off (INT MUTE)

INT MUTE ON / INT MUTE OFF (Initial setting)

If a device having the interrupt feature is connected, audio will be automatically muted whenever the interrupt signal is received from the device.

- When **BLUETOOTH** is set to **ADPT**, **INT MUTE** cannot be set. Refer to "Setting the **BLUETOOTH** Connection" (page 23).
- When the **BLUETOOTH INTERFACE (KCE-400BT)** is connected, set **INT MUTE** to **OFF**.

Setting the AUX+ Mode

AUX+ ON / AUX+ OFF (Initial setting)

You can input the audio of an external device, (such as a Portable audio player) to the **BLUETOOTH** interface connector of this unit. A special Conversion cable (KCE-237B) is necessary to adapt the **BLUETOOTH** interface connector as an **AUX IN**.

An external device and a **BLUETOOTH INTERFACE (KCE-400BT)** cannot be connected at the same time.

- AUX+ ON : Set to ON when an external device is connected. If **TUNER/SOURCE** is pressed and **AUX+** is selected, the sound of the external device is input to the unit.

AUX+ OFF : When set to OFF, **AUX+** source cannot be selected.

Setting the AUX+ NAME Mode

AUX (Initial setting) / TV / DVD / PORTABLE / GAME

You can change the **AUX+** NAME when **AUX+** is ON.

Setting the AUX ZONE Mode

OFF (Initial setting) / ON

You can input the audio of an external device, (such as a Portable music player) to the **AUX** Input Terminal connector of this unit. And an optional adapter cable is required (standard RCA to 3.5 ϕ mini-phonograph plug or 3.5 ϕ to 3.5 ϕ mini phonograph plug).

- AUX ZONE ON: Set to ON when an external device is connected. If **TUNER/SOURCE** is pressed and **AUX ZONE** is selected, the sound of the external device is input to the unit.

AUX ZONE OFF: When set to OFF, **AUX ZONE** source cannot be selected.

Setting the AUX ZONE NAME mode

AUX (Initial setting) / TV / DVD / PORTABLE / GAME

You can change the AUX Zone Name when AUX ZONE is set to ON.

Setting the AUX Mode (V-Link)

AUX ON / AUX OFF (Initial setting)

You can input TV/video sound by connecting an optional Ai-NET/RCA Interface cable (KCA-121B) or Versatile Link Terminal (KCA-410C) to this component.

You can change the AUX NAME display when AUX is set to ON. Press **Q/ENTER** when AUX is set to ON, and select AUX NAME by turning the **Rotary encoder**, then press **Q/ENTER**.

After that, turn the **Rotary encoder** to select the desired AUX name.

If the KCA-410C is connected, it is possible to select two AUX names.

- Via KCA-410C, up to 2 external devices with RCA output can be connected. In this case, press **TUNER/SOURCE** to select AUX mode, and then press **TUNER/SOURCE** again to select your desired device.

Setting the Changer Name

CHANGER (Initial setting) / PORTABLE

When an optional changer is connected, you can set the displayed mode name.

- The setting can be made only when a changer is connected. When two changers are connected, the **CHANGER1 NAME/CHANGER2 NAME** is displayed, and the setting can be made respectively.

Setting the External Digital Input (DIGITAL AUX)

DIGITAL AUX ON / DIGITAL AUX OFF (Initial setting)

When an ALPINE Ai-NET compatible digital audio processor (PXA-H701) and a DVD player (DVE-5207) not compatible with Ai-NET are connected, set DIGITAL AUX to ON to enjoy 5.1-channel surround sound.

You can change the D-AUX Name when DIGITAL AUX is set to ON. Press **Q/ENTER** when DIGITAL AUX is set to ON, and select D-AUX NAME by turning **Rotary encoder**, then press **Q/ENTER**.

- Press **TUNER/SOURCE**, and select the D-AUX mode, and adjust the volume, etc.
- After input selection is completed, turn the ignition off and back on again. Setting of the optical digital input switch is completed.
- Depending on the connected audio processor, DVD player sound may continue to be output, even though the source is changed to another one. If this occurs, set the DVD player's power to OFF.

Setting the AUX+ Level (AUX IN GAIN)

LOW (Initial setting) / HI

After setting to ON in "Setting the AUX+ Mode", this setting can be carried out.

LOW : Decreases the external input audio level.

HI : Increases the external input audio level.

Connecting to an External Amplifier (POWER IC)

ON (Initial setting) / OFF

When an external amplifier is connected, sound quality can be improved by stopping the power supply of the built-in amplifier.

POWER IC OFF : Use this mode when the front pre-amplifier of the unit is used to drive an external amplifier connected to the speakers. In this setting, the head unit's internal amplifier has no output to drive speakers.

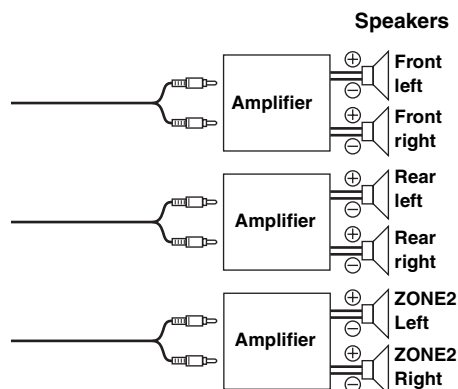

POWER IC ON : The speakers are driven by the built-in amplifier.

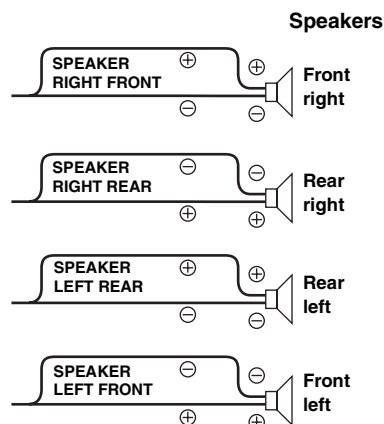

- No sound is produced by the system when the POWER IC is set to OFF.

Demonstration

DEMO ON / DEMO OFF (Initial setting)

This unit has a Demonstration feature for the display.

- To quit Demo mode, set to DEMO OFF.

Display Setting

DISPLAY is selected on the setup main menu in step 2.

Volume Level Bar Setting (VOL DISP)

ZONE1 (Initial setting) / ZONE2

When Volume mode is set to ALL, you can select the volume level bar for ZONE1 or ZONE2 on LCD display.

Changing Lighting Color (ILLUMINATION)

TYPE1 (Initial setting) / TYPE2

You can change the lighting color of the unit's buttons.

TYPE1 : The color of the buttons is blue.

TYPE2 : The color of the buttons is red.

Dimmer Control (DIMMER)

MANUAL / AUTO (Initial setting)

Set the Dimmer control to AUTO to decrease the illumination brightness of the unit when the boat's running lights are ON. This mode is useful if you feel the unit's backlighting is too bright at night.

Dimmer Level Setting (DIMMER LEVEL)

LVL 1 (Initial setting) / LVL 2 / LVL 3

In the Dimmer Level setting, three levels are available, the highest level (LVL 3) being the dimmest when the boat's running lights are on.

Scroll Type Setting (SCROLL TYPE)

TYPE1 / TYPE2 (Initial setting)

Choose from two scrolling methods.

Select the type you prefer.

TYPE1 : The characters scroll from right to left, a single character at a time.

TYPE2 : Words are built up from left to right, a single character at a time. When the display is filled, it is cleared and the remaining words are displayed the same way until all words of the title have been shown.

Scroll Setting (TEXT SCROLL)

AUTO / MANUAL (Initial setting)

You can set a scroll type such as song title or file name on the source screen. If the text display extends beyond the limits of the screen, the text scrolls to show the off-screen text.

TEXT SCROLL AUTO : Text information are scrolled automatically.

TEXT SCROLL MANUAL : The first display scrolls text information one time only.

- In parts of the display, scrolling may not occur, or scroll content may differ.
- Regardless of this setting, if the display is filled with text, the display scrolls.

iPod Setting

IPOD is selected on the setup main menu in step 2.

iPod Search Mode Setting

ON / OFF

The unit allows you to search for the iPhone/iPod using eight different search modes.

When the search mode is in PLAYLISTS/ARTISTS/ALBUMS/PODCASTS/AUDIO BOOKS, the initial setting is ON, and when the search mode is in GENRES/COMPOSERS/SONGS, the initial setting is OFF.

- For search mode details, refer to "Searching for a desired Song" (page 15).

SIRIUS Radio Setting (Only when a SIRIUS Receiver Box is connected)

SIRIUS is selected on the setup main menu in step 2.

Unlock the Locked Channels (CLEAR LOCK)

YES / NO

The connected optional SIRIUS Receiver Box may have the ability to lock out channels with password protection. The locked channels can not be accessed with this unit. However, the following operation will clear the lock to receive these channels as normal.

YES : Unlock the locked channels.

NO : Keep the lock state.

- You cannot set a channel as lock channel from this unit. Please operate from the SIRIUS Receiver Box. For details, refer to the owner's manual of the optional SIRIUS Receiver Box.
- Depending on the connected SIRIUS Interface devices, this setting item may not be displayed.

Clearing the Setting of Skipped Channels (CLEAR SKIP)

YES / NO

The optional SIRIUS Receiver Box may have the ability to create an undesired channel list. Using the channel UP/DOWN operation skips the channels in this list automatically. The following operation will prevent the skipping of the listed channels.

YES : Clear the setting of skipped channels.

NO : Keep the skip state.

- You cannot set a channel as skipped channel from this unit. Please operate from the SIRIUS Receiver Box. For details, refer to the owner's manual of the optional SIRIUS Receiver Box.
- Depending on the connected SIRIUS Interface, this setting item may not be displayed.



Setting the Favorite Sports Team announcement (SPORTS)

FAVORITE TEAMS / GAME ALERT

The following operation sets the announcement for your favorite sports team.

FAVORITE TEAMS:

After access to this item, a sports league list will be displayed.

- 1 Turn the Rotary encoder to select the desired league, and then press /ENTER.**
- 2 Turn the Rotary encoder to select a team you want to store, and then press /ENTER.**
The screen will ask which kind of alert you wish to have.
 - Select "NONE" on the list if you do not want to store in memory. No alert interruption will occur.
- 3 Turn the Rotary encoder to select the desired alert type, and then press /ENTER.**

SCORE ↔ INITIAL

SCORE : The alert display interrupts by game progress (change of score, game result, etc.).

INITIAL : The alert display interrupts when the game begins.

GAME ALERT:

After access to this item, operate the unit as follow.

Turn the Rotary encoder to set GAME ALERT to ON or OFF, and then press Q/ENTER.

If ON is set, the alert for all stored sports teams is set.

If OFF is set, no announcements will be made.

Setting the Sirius Seek (S-SEEK) Alert

S-SEEK ALERT / DELETE ALL / MEMORY RECALL

The following operations can be performed to change the Sirius Seek Alert settings.

S-SEEK ALERT:

This feature allows you to capture information in the Receiver's memory about the currently tuned programming— artist or song. When S-SEEK ALERT is ON, the Receiver then continuously searches all incoming SIRIUS channels and alerts the user when a program saved in memory matches a selection currently being played. After access to this item, operate the unit as follows.

Turn the Rotary encoder to set S-SEEK ALERT to ON or OFF, and then press Q/ENTER.

If ON is set, the alert for all stored Artists/Songs is set.

If OFF is set, no announcements will be made.

DELETE ALL:

The operation will delete all alerts (artists, songs and team) stored in memory.

After access to this item, operate the unit as follows.

Turn the Rotary encoder to select YES, and then press Q/ENTER.

MEMORY RECALL:

You can manage the stored Alert (Artist, Songs, Sports team) individually by this setting.

After access to this item, the alert memory select screen will be displayed.

Display example for alert memory select screen

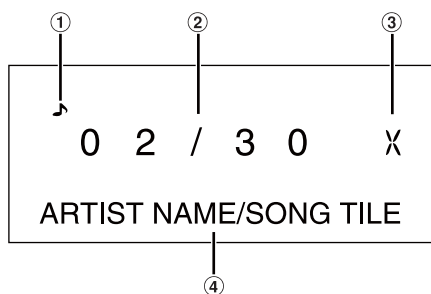

- ① Display the type of the stored memory recall.

🚗 : Artist Memory Recall

🎵 : Song Memory Recall

- When display sport team memory recall, no icon is displayed.

- ② Display the sequence number of stored alert item and the total items can be stored.

- ③ Displayed when ALERT is set to OFF.

- When the ALERT is ON, no icon is displayed.

- ④ Display the artist, song or team name.

- 1 Turn the Rotary encoder to select the desired alert item, and then press Q/ENTER.

The manage list for the selected alert is displayed. You can set the alert to on, off or delete the alert. You can select the alert type if the managed alert is a song alert or a game alert.

- 2 Turn the Rotary encoder to select the desired setting, and then press Q/ENTER.

If the selected alert is ARTIST ALERT, you can manage the alert as following:

ON*¹ ↔ OFF*² ↔ DELETE*³

*¹ Set the stored Artist alert to on.

*² Set the stored Artist alert to off.

*³ Delete the stored Artist alert.

If the selected alert is SONG ALERT, you can manage the alert as following:

ON*¹ ↔ OFF*² ↔ A ONLY*³ ↔ DELETE*⁴

*¹ Set the stored Song alert to on.

*² Set the stored Song alert to off.

*³ Only set the stored Song's artist alert to on.

*⁴ Delete the stored Song alert.

If the selected alert is GAME ALERT, you can manage the alert as following:

INITIAL*¹ ↔ SCORE*² ↔ OFF*³ ↔ DELETE*⁴

*¹ The alert display interrupts when the game begins.

*² The alert display interrupts by game progress (change of score, game result, etc.).

*³ Set the stored Game alert to off.

*⁴ Delete the stored Game alert.

- If you want to delete a alert memory in the above procedure, a delete confirmation screen will appear, turn the Rotary encoder to select "YES", and then press Q/ENTER.
- Depending on the connected SIRIUS Interface, some setting items and display indications do not work.

HD Radio Reception Setting (Only when HD Radio tuner module receiver is connected)

HD RADIO mode is selected on the setup main menu in step 2.

HD Radio Station Call Setting

STATION CALL LONG / STATION CALL SHORT (Initial setting)

In the HD Radio mode, the number of display characters for the HD Radio station name can be selected.

LONG : 56 characters

SHORT : 7 characters (FM)

4 characters (AM)

Digital Seek On/Off Setting

DIGITAL SEEK ON / DIGITAL SEEK OFF (Initial setting)

ON : SEEK UP/DOWN is used only for Digital Radio Station.

OFF : SEEK UP/DOWN is used for all Radio Stations.

SAT Radio Receiver (Optional)

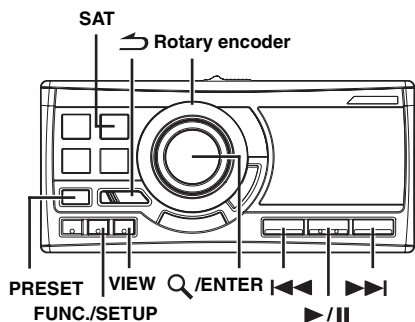

SAT Receiver: XM or SIRIUS Receiver
When an optional XM or SIRIUS Receiver Box is connected via the Ai-NET bus, the following operations may be performed. However, the XM Receiver and SIRIUS Receiver cannot be connected at the same time.

SIRIUS Receiver: Verify the features of the connected SIRIUS Receiver Box. Not all SIRIUS Receivers have identical functions and some may not be performed on this unit. For details about individual functions, refer to the SIRIUS Receiver's Owner's Manual.

Receiving Channels with the SAT Radio Receiver (Optional)

About SAT Radio

Satellite Radio* is the next generation of audio entertainment, with over 100 digital audio channels. For a small monthly fee, subscribers can hear crystal-clear music, sports, news and talk, coast-to-coast via satellite. For more information, visit XM's website at www.xmradio.com, or SIRIUS' website at www.sirius.com.

To receive SAT Radio, the separately sold XM Direct™ or SIRIUS Satellite Radio Tuner and an appropriate Ai-NET Interface Adapter will be required. For details, consult you nearest Alpine dealer.

* XM and its corresponding logos are trademarks of XM Satellite Radio Inc.

* SIRIUS and its corresponding logos are trademarks of SIRIUS Satellite Radio Inc.

• The SAT Receiver controls on this unit are operative only when a SAT Receiver is connected.

- 1 Press **SAT** to activate the SAT Radio mode.
 - 2 Press **◀◀** or **▶▶** to select the desired channel.
Holding down **◀◀** or **▶▶** will change channels continuously.
- When using the optional remote control (RUE-4190, etc.), an SAT Radio Channel can be directly called up with the numeric keypad of the remote control.
 - 1 While in XM or SIRIUS Radio mode, enter the Channel number you want to call up with the numeric keypad on the remote control.
 - 2 Press **ENTER** on the remote control within 5 seconds to receive the channel.

Checking the SAT Radio ID Number

A unique Radio ID number is required to subscribe to SAT Radio programming. Each third party XM or SIRIUS radio comes with this number.

This number is an 8 character (for XM Radio) or 12 character (for SIRIUS Radio) alphanumeric number. It is printed on a label found on the SAT Receiver.

It can also be displayed on the screen of this unit in the following way.

XM:

- 1 While receiving a XM Radio band, press **◀◀** or **▶▶** to select channel "0" for XM.

The unit displays "RADIO ID" and ID number simultaneously.

While displaying "RADIO ID" as shown above, Demonstration become nonfunctional (refer to "Demonstration" on page 25).

- 2 To cancel the ID number display, select the channel other than "0".

SIRIUS:

- 1 While receiving a SIRIUS Radio band, press **◀◀** or **▶▶** to select channel "255" or "0" for SIRIUS.

- 2 Press **VIEW** until the ID No. appears in the display.
The SIRIUS ID is displayed when the Song Name display mode is toggled. For details, refer to "Changing the Display" (page 12).

- 3 To cancel the ID number display, set the channel to other than "255" and "0".

• You can check the ID number printed on a label on your third party, SAT Radio Receiver package.

Storing Channel Presets

- 1 Press and hold **PRESET** for at least 2 seconds.
The Preset screen is displayed.
- 2 Turn the **Rotary encoder** to select the preset number.
- 3 Press and hold **Q/ENTER** for at least 2 seconds.
The selected channel is stored.

• A total of 18 channels can be stored in the preset memory for either XM or SIRIUS.

• If you store a channel in a preset memory which already has a station, the current channel will be cleared and replaced with the new one.

Receiving Stored Channels

1 Press and hold **PRESET** for at least 2 seconds.

The Preset screen is displayed.

2 Turn the **Rotary encoder** to select a radio station.

3 Press **Q/ENTER**.

The selected channel is received.

- You can also call up the desired preset memory by pressing **PRESET** repeatedly.

Storing the desired Sports Team (SIRIUS only)

Store a favorite team from one of the available leagues SIRIUS covers. Once stored, game times and scores for that team are announced using the interruption Alert display while receiving other programming. To receive these announcements, refer to “Activating the stored Alert (SIRIUS only)” on page 30.

This function becomes effective after performing the following operation and set **GAME ALERT** to **ON**. On how to set **GAME ALERT** to **ON**, refer to “Setting the Favorite Sports Team announcement (SPORTS)” (page 26).

Storing while receiving a game broadcast

1 Select the channel broadcasting your favorite team's game.

2 Press **FUNC./SETUP** to activate the Function mode.

3 Turn the **Rotary encoder** to select **MEMORY**, and then press **Q/ENTER** to activate the Memory mode.

4 Turn the **Rotary encoder** to select the desired team for the game being broadcast, and then press **Q/ENTER**.

5 Turn the **Rotary encoder** to select alert type, and then press **Q/ENTER**.

SCORE ↔ INITIAL

SCORE : The Alert display interrupts by game progress (change of score, game result, etc.).

INITIAL : The Alert display interrupts when the game begins.

6 The new alert was stored in memory.

A “GAME STORED” pop-up screen followed by an “X USED Y EMPTY”.

X is the total number of listings stored in memory, and Y is the total number of memory listings still available for storage.

7 Press **FUNC./SETUP** to cancel the Function mode.

- If you try to store when the memory area is full, “MEMORY FULL” is displayed for 2 seconds. Following that display, the existing alert list stored in memory is shown. Select one of the stored alerts using the **Rotary encoder**. To replace the selected alert, press **Q/ENTER** and a “REPLACE YES” or “REPLACE NO” screen will then be displayed. Select “REPLACE YES” by turning the **Rotary encoder**, and then press **Q/ENTER**.
- You can manage the stored Alert memory setting on Setup mode, for details refer to “Setting the Sirius Seek (S-SEEK) Alert” on page 27.
- You can also store the desired sports teams on Setup mode, for details, refer to “Setting the Favorite Sports Team announcement (SPORTS)” on page 26.
- If no operation is performed for 60 seconds, the unit returns to normal mode.

Storing the desired Song / Artist (SIRIUS only)

A stored song title or artist name is announced whenever a matching title or artist is found on another channel. The interruption Alert is displayed while listening to a program on another channel. For receiving interruption information, refer to “Activating the stored Alert (SIRIUS only)” (page 30).

1 Press **FUNC./SETUP** to activate the Function mode when a Song or the song of an Artist you want to store is being broadcast.

2 Turn the **Rotary encoder** to select **MEMORY**, press **Q/ENTER** to activate the Memory mode.

3 Turn the **Rotary encoder** to select **SONG** or **ARTIST** (when available), and then press **Q/ENTER**.

4 The new Alert was stored in memory.

A “ARTIST/SONG STORED” pop-up screen is followed by an “X USED Y EMPTY”.

X is the total number of listings stored in memory, and Y is the total number of memory listings still available for storage.

- If no operation is performed for 60 seconds, the unit returns to normal mode.
- If you try to store when the memory area is full, “MEMORY FULL” is displayed for 2 seconds. Following that, display, the existing alert list stored in memory is shown. Select one of the stored alerts using the **Rotary encoder**. To replace the selected alert, press **Q/ENTER** and a “REPLACE YES” or “REPLACE NO” screen will then be displayed. Select “REPLACE YES” by turning the **Rotary encoder**, and then press **Q/ENTER**.
- You can manage the stored Alert memory setting on Setup mode, for details, refer to “Setting the Sirius Seek (S-SEEK) Alert” on page 27.

Activating the stored Alert (SIRIUS only)

Make sure that GAME ALERT (Refer to “Setting the Favorite Sports Team announcement (SPORTS)” on page 26)/S-SEEK ALERT (Refer to “Setting the Sirius Seek (S-SEEK) Alert” on page 27) is set to ON. When the Game Alert/S-Seek option is enabled. Whenever the stored sports team, artist(s) or song(s) are playing, an interruption Alert appears in the display of the unit.

The interruption () ALERT indicator is either on or blinking depending on the conditions listed below.

() (ALERT) indicator lights : one Alert found.

() (ALERT) indicator blinks : more than 2 Alerts found.

If more than 2 Alerts are found (Blinking ALERT indicator):

1 Turn the Rotary encoder to select the desired information.

2 Press  /ENTER.

The selected channel containing the desired information is received.

- You can toggle the display between the artist name list and the song/program title list or toggle the game information by pressing **VIEW** in this step.
- If no operation is performed for 60 seconds, the unit returns to normal mode.
- Sports teams/Artist name and Song title that you have stored and that are currently playing will be displayed in a category called “GAME ZONE”/“S-SEEK LIST” in search mode. For details, refer to “Search Function” on page 30.

Search Function

You can search for programs by Category, Channel.

Category Search mode

1 Press  /ENTER in the XM or SIRIUS mode.

2 Turn the Rotary encoder to select Category Search mode, and then press  /ENTER.

CATEGORY ↔ CHANNEL ↔ S-SEEK LIST* ↔
GAME ZONE* ↔ CATEGORY

* *SIRIUS Only. Displayed only when () appears. For details, refer to “Activating the stored Alert (SIRIUS only)” on page 30.*

3 Turn the Rotary encoder to select the desired Category, and then press  /ENTER.

4 Turn the Rotary encoder to select the desired Channel Name, and then press  /ENTER.

- During channel search, press **◀◀** or **▶▶** to select another Category.
- While in Category Search mode, press **↶** to return to the selecting search mode.
- The Search mode is canceled if you press and hold **↶** for at least 2 seconds, or no operation is performed for 60 seconds in Category Search mode.
- During Channel search, You can toggle the display between the channel name list, artist name list and the song/program title list by pressing **VIEW** (SIRIUS only).

Channel Search mode

1 Press  /ENTER in the XM or SIRIUS mode.

2 Turn the Rotary encoder to select Channel Search mode, and then press  /ENTER.

CATEGORY ↔ CHANNEL ↔ S-SEEK LIST* ↔
GAME ZONE* ↔ CATEGORY

* *SIRIUS Only. Displayed only when () appears. For details, refer to “Activating the stored Alert (SIRIUS only)” on page 30.*

• During Channel search, pressing **VIEW** will toggle the display between the channel name list, artist name list and the song/program title list.

3 Turn the Rotary encoder to select the desired Channel, and then press  /ENTER.

- When the () appears, the “S-SEEK LIST” or “GAME ZONE” (which displays a list of the current matches) should be accessible via view search options. You can select the artist, song, or sports game that you wish to tune to by turning the **Rotary encoder** from the list, and then press **Q/ENTER**. During the searching, you can toggle the display between the artist name list and the song/program title list or toggle the display between the team names and the current score of any live play-by-play game by pressing **VIEW**.
- Press **↶** in the search mode to return to the previous mode.
- The Search mode is canceled if you press and hold **↶** for at least 2 seconds, or no operation is performed for 60 seconds.
- Depending on the connected SIRIUS Interface, some functions and display indications do not work.

Quick Search Function

You can search for all channels in numerical order.

1 Press and hold  /ENTER for at least 2 seconds in XM or SIRIUS mode to activate Quick Search mode.

• Only when the Quick Search is ON, refer to “Setting the Quick Search ON and OFF” (page 8).

2 Turn the Rotary encoder to select the desired Channel within 10 seconds.

The selected Channel is received.

Select the desired CATEGORY (Category up/down)

1 Press and hold  /ENTER for at least 2 seconds to Category Up/Down mode.

• Only when the Quick Search is OFF, refer to “Setting the Quick Search ON and OFF” (page 8).

2 Turn the Rotary encoder to select the desired Category within 10 seconds.

The first channel in the selected Category is played back.

Receiving Weather or Traffic Information from SAT Radio

- Select the SAT Radio Channel for your local traffic/ weather information.**
- Press and hold ►/|| for at least 2 seconds in the SAT mode.**
The received weather or traffic channel is stored.
- Press and hold SAT for at least 2 seconds.**
The stored Weather or Traffic channel will be recalled.
- Press and hold SAT for at least 2 seconds.**
Returns to normal mode.

- Channel other than Weather or Traffic can also be stored and recalled.

Instant Replay Function (SIRIUS only)

In SIRIUS mode, the current channel is saved using the Instant Replay memory function. Use this function to pause the channel content at any time. When playback is continued, it will begin at the position it was paused.

- During SIRIUS reception, press ►/|| to place the Receiver in the Instant Replay pause mode, which mutes the audio.**
"INSTANT REPLAY" is displayed.
- Press ►/|| again to have the Receiver resume playback of the stored audio from the point at which it was paused.**
During playback, the Receiver will continue to store the channel audio until you exit the Instant Replay mode. During REPLAY playback, the "I.R." indicator lights up.



During Instant Replay playback:

Fast reverse: Press and hold ◀◀.

Fast forward: Press and hold ▶▶.

Returning to the beginning of the current song: Press ◀◀◀.

Advancing to the beginning of the next song: Press ▶▶▶.

- If you continue to press Fast forward until the end, the Instant Replay mode is canceled, and the unit will change to usual reception.

- Press ↶ for at least 2 seconds to cancel the Instant Replay mode.**
The unit returns to usual SIRIUS broadcasting mode.

Changing the Display

Text information, such as the channel name, artist name/feature, and song/program title, is available with each XM or Sirius channel. The unit can display this text information as explained below.

In XM or SIRIUS mode, press VIEW.

Each time you press this button, the display changes as shown below.

XM mode:

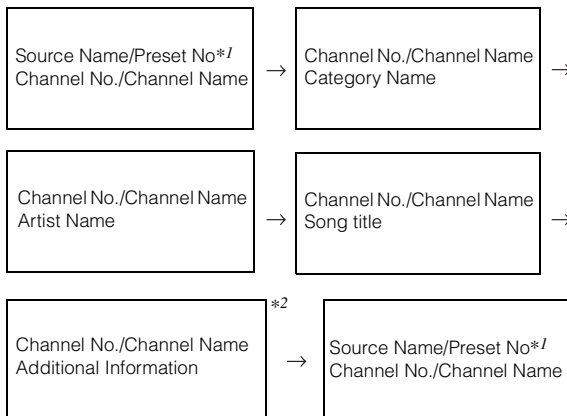

SIRIUS mode:

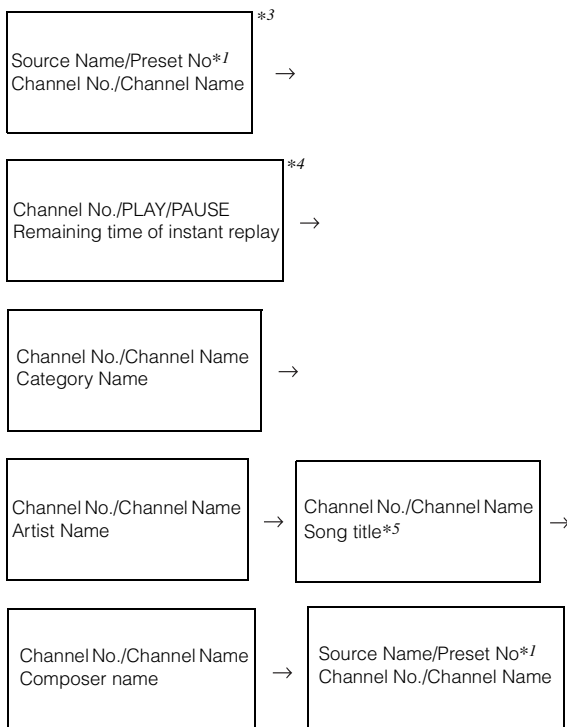

*1 Displayed only when the current channel is the preset one.

*2 When ADF is turned OFF, this information is not displayed (see "Setting the Auxiliary Data Field Display (XM only)" on page 32.

*3 Not displayed in instant replay.

*4 Displayed only during instant replay.

*5 When the channel "0" or "255" is selected, the SIRIUS ID number is displayed.

- When the “Scroll Setting (TEXT SCROLL)” (page 26) is set to “AUTO”, the channel name and song title scrolls continuously. When the Scroll Setting is set to “MANUAL”, the song title scrolls only once.
- Depending on the model, the display may differ from the one shown above.

Setting the Auxiliary Data Field Display (XM only)

The XM Auxiliary Data Field (ADF) display can be switched on or off. There is no ADF function for the SIRIUS receiver.

- 1 Press and hold **FUNC./SETUP** for at least 2 seconds to activate the **SETUP** selection mode.
- 2 Turn the **Rotary encoder** to select the **XM mode**, and then press **Q/ENTER**.

BT*¹ ↔ AUDIO ↔ GENERAL ↔ DISPLAY ↔ IPOD ↔ XM/SIRIUS*² ↔ HD RADIO*³ ↔ BT

*¹ Displayed only when INT MUTE is set to OFF, and the mode is set to other than BT AUDIO.

*² Only when SAT Radio receiver is connected.

*³ Only when HD Radio tuner module is connected.

- 3 Press **Q/ENTER** to activate the **XM ADF mode**.
- 4 Turn the **Rotary encoder** to select **XM ADF ON/OFF**, and then press **Q/ENTER**.

When setting to ON, Auxiliary Data Field is displayed by pressing VIEW (refer to “Changing the Display” on page 31).

- 5 Press and hold **SETUP** for at least 2 seconds to return to normal mode.

- Pressing ↶ returns to the previous **SETUP** mode.
- If no operation is performed for 60 seconds, **SETUP** is canceled.

IMPRINT Operation (Optional)

Alpine introduces IMPRINT - the world’s first technology that thoroughly eliminates in-boat acoustic problems that normally degrade sound quality, which enables us to experience music the way the artist intended.

When the IMPRINT audio processor (PXA-H100) (sold separately) is connected to this unit, MultEQ and the following sound adjustment can be performed.

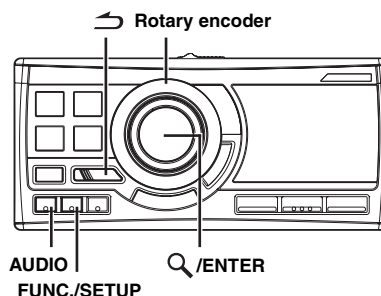

Changing MultEQ mode

MultEQ, developed by Audyssey Labs, automatically corrects the audio for the listening environment. The system is optimized for selected positions in the boat. To accomplish this, MultEQ must take measurements of the boat’s response characteristics. For details on the set up procedure, consult your authorized Alpine dealer.

- 1 Press and hold **AUDIO** for at least 2 seconds.
- 2 Press **Q/ENTER**.
- 3 Turn the **Rotary encoder** to select the **MultEQ mode**, and then press **Q/ENTER**.

OFF (Manual Mode) → CURVE1 (MultEQ-1) → CURVE2 (MultEQ-2) → OFF (Manual Mode)

- 4 Press and hold **AUDIO** for at least 2 seconds to return to normal mode.

- The Curve mode can be selected only when curve 1 and curve 2 are stored.
- When using MultEQ, MX, X-OVER, Time Correction, Factory’s EQ, SUBW PHASE, SUBW CHANNEL, TW Setup, EQ Mode, Filter Type, Parametric EQ and Graphic EQ are set automatically. They are no longer user adjustable.
- When an external audio processor is connected, the MultEQ function cannot be used.

Adjusting Sound Setting in Manual Mode

You can change these sound settings to create your own preference when the MultEQ mode is set to MultEQ off (Manual Mode). However, subwoofer in the subwoofer system can be set to ON/OFF regardless of whether the MultEQ setting is ON or OFF.

Use steps 1 to 5 to select one of the Sound menu modes to modify. See the applicable section below for details about the selected item.

1 Press and hold **FUNC./SETUP for at least 2 seconds to activate the **SETUP** selection mode.**

2 Turn the **Rotary encoder to select **AUDIO**, and then press **Q/ENTER**.**

BT*¹ ↔ AUDIO ↔ GENERAL ↔ DISPLAY ↔ IPOD ↔ XM/SIRIUS*² ↔ HD RADIO*³ ↔ BT

*¹ Displayed only when INT MUTE is set to OFF, and the mode is set to other than BT AUDIO.

*² Only when SAT Radio receiver is connected.

*³ Only when HD Radio tuner module is connected.

3 Turn the **Rotary encoder to select the desired item, and then press **Q/ENTER**.**

AUX ZONE SELECT*⁴ ↔ MUTE LEVEL ↔ USER PRESET ↔ MX ↔ FR-EQ ↔ SOUND FIELD*⁵ ↔ SUBW ↔ SUBW SYS*⁶ ↔ SUBW PHASE*⁶ ↔ SUBW CHANNEL*⁶ ↔ TW*⁷ ↔ EQ MODE ↔ FILTER ↔ TCR ↔ MX LEVEL*⁸ ↔ AUX ZONE SELECT*⁴
(e.g. Select SUBW)

*⁴ Displayed only when AUX ZONE is set to ON.

*⁵ In step 3, three sound adjustment items (PARAMETRIC EQ/ GRAPHIC EQ, TIME CORRECTION, X-OVER) can be selected in Sound Field Adjustment mode, turn the **Rotary encoder** to select the desired item, and then press **Q/ENTER** to continue to step 4.

*⁶ These functions are inoperable when Subwoofer is set to OFF.

*⁷ This function can be operable only when PXA-H100 (sold separately) is connected and 2.2ch (3WAY) mode is set. For details, refer to the Owner's Manual of PXA-H100.

*⁸ This function is inoperable when MX is set to OFF.

4 Turn the **Rotary encoder to change the setting, and then press **Q/ENTER**.**

(e.g. Select SUBW ON or SUBW OFF)

5 Press and hold **↵ for at least 2 seconds to return to normal mode.**

- Media Xpander, Factory's EQ, Parametric EQ/Graphic EQ Adjustment, EQ Mode and MX Level Adjustment are inoperable when DEFEAT is set to ON.
- Pressing **↵** returns to the previous Sound menu mode.
- If no operation is performed for 60 seconds, Sound menu mode is canceled.

USER PRESET

- If IMPRINT audio processor is connected, you can make more detailed settings for the audio setting. For details, refer to "IMPRINT Operation (Optional)" (page 32).

Storing the Audio Adjustment Level

You can store up to 3 adjusted/set contents on this unit.

All of the following adjusted/set items are stored in a preset memory.

Items to be adjusted/set	Reference page
EQ ADJ (Parametric EQ/Graphic EQ)	page 34~page 34
TCR	page 34
X-OVER	page 35

1 Turn the **Rotary encoder to select a preset number, and press and hold **Q/ENTER** for at least 2 seconds.**

2 Turn the **Rotary encoder to select **PROTECT YES/NO**, and then press **Q/ENTER** to store the adjusted contents.**

PROTECT YES (Initial setting) ↔ PROTECT NO

- If YES is selected, the adjusted contents are protected and stored into the preset numbers. When you want to store the parameter into a protected preset number, "REPLACE NO/YES" can be selected.
- If PROTECT NO is selected, the preset is stored.
- While performing this operation, all adjusted contents of Parametric EQ/Graphic EQ, Time Correction and X-Over will be stored in the preset number.
- The stored contents are not deleted even when resetting the unit or disconnecting the battery.

Recalling the Audio Adjustment Level

You can recall the contents stored in "Storing the Audio Adjustment Level" (page 33).

1 Turn the **Rotary encoder to select a preset number, and press **Q/ENTER**.**

Adjusted/set contents of the selected number are recalled.

Turning Media Xpander ON/OFF

When the Media Xpander is on, you can adjust the Media Xpander level (refer to page 36).

OFF (Initial setting) ↔ ON

Equalizer Presets (Factory's EQ) (FR-EQ)

10 typical equalizer settings are preset at the factory for a variety of musical source material.

FLAT ↔ POPS ↔ ROCK ↔ NEWS ↔ JAZZ&BLUES ↔ ELECTRICAL DANCE ↔ HIPHOP&RAP ↔ EASY LISTENING ↔ COUNTRY ↔ CLASSICAL ↔ USER1 ↔ USER2 ↔ USER3 ↔ USER4 ↔ USER5 ↔ USER6

- By selecting User's 1 to 6, you can recall the stored preset number in "Adjusting the Graphic Equalizer Curve" (page 34) or "Adjusting the Parametric Equalizer Curve" (page 34).

Sound Field Adjustment

The setting of Parametric EQ/Graphic EQ Adjustment, Time Correction and X-Over can be adjusted in this mode.

Adjusting the Parametric Equalizer Curve

You can modify the Equalizer settings to create a response curve more appealing to your personal taste. To adjust the Parametric Equalizer Curve, set the EQ mode to PARAMETRIC EQ. For details, refer to "Setting EQ mode" (page 36).

- 1 After selecting EQ ADJ (Parametric EQ) from the Sound Field Adjustment mode, turn the Rotary encoder to select the band adjustment, and then press **Q/ENTER**.

BAND1 → BAND2 → BAND3 → BAND4 → BAND5 → BAND1

- 2 Turn the Rotary encoder to select an item to adjust, then press **Q/ENTER**.

FC → LV → Q → FC
(frequency) (level) (bandwidth) (frequency)

Frequency Adjustment

- 3-1 Turn the Rotary encoder to select frequency bands.

Adjustable frequency bands:
20 Hz to 20 kHz (in 1/3 octave steps)

BAND1: 20 Hz~80 Hz (63 Hz)
BAND2: 50 Hz~200 Hz (150 Hz)
BAND3: 125 Hz~3.2 kHz (400 Hz)
BAND4: 315 Hz~8 kHz (1 kHz)
BAND5: 800 Hz~20 kHz (2.5 kHz)

Level Adjustment

- 3-2 Turn the Rotary encoder to adjust the level.

Adjustable level: -6 to +6 dB

Bandwidth (Q) Adjustment

- 3-3 Turn the Rotary encoder to set the bandwidth (Q).

Adjustable bandwidth: 1, 1.5, 3

- 4 To adjust another band, repeat steps 1 to 3 and adjust all bands.

- The frequencies of adjacent bands cannot be adjusted within 4 steps.
- While adjusting the Parametric EQ, you should consider the frequency response of the connected speakers.

Adjusting the Graphic Equalizer Curve

You can modify the equalizer settings to create a response curve more appealing to your personal taste. To adjust the graphic equalizer curve, set the EQ mode to GRAPHIC EQ. For details, refer to "Setting EQ mode" (page 36).

- 1 After selecting EQ ADJ (Graphic EQ) from the Sound Field Adjustment mode, turn the Rotary encoder to select the band adjustment, and then press **Q/ENTER**.

BAND1 → BAND2 → BAND3 → BAND4 → BAND5 → BAND6 → BAND7 → BAND1

BAND-1 (63 Hz) / BAND-2 (150 Hz) / BAND-3 (400 Hz) / BAND-4 (1 kHz) / BAND-5 (2.5 kHz) / BAND-6 (6.3 kHz) / BAND-7 (17.5 kHz)

- 2 Press **Q/ENTER** to activate the level adjusting mode.

- 3 Turn the Rotary encoder to adjust the level.

Adjustable output level: -6 to +6 dB

- 4 To adjust another band, repeat steps 1 to 3, and then adjust all bands.

Adjusting the Time Correction

Before performing the following procedures, refer to "About Time Correction" (page 37).

- 1 After selecting TIME CORRECTION from the Sound Field Adjustment mode, turn the Rotary encoder to select the band adjustment, and then press **Q/ENTER**.

2.2ch (3WAY) System

F-L (Initial setting) → F-R → R-L → R-R →
(Mid-L) (Mid-R) (High-L) (High-R)
SW-L → SW-R → F-L
(Mid-L)

4.2ch (FRONT/REAR/SUBW.) System

F-L (Initial setting) → F-R → R-L → R-R →
(Front-L) (Front-R) (Rear-L) (Rear-R)
SW-L → SW-R → F-L
(Front-L)

- 2 Press **Q/ENTER** to activate the Time Correction input mode.

- 3 Turn the Rotary encoder to adjust the distance (0.0 to 336.6 cm).

L = (distance to farthest speaker) - (distance to other speakers)

Refer to "Time Correction Value List" on page 37.

- 4 Repeat steps 1 to 3 to set another speaker.

Set these values to achieve simultaneous sound propagation to the listening position.

Adjusting the Crossover Settings (X-OVER)

Before performing the following procedures, refer to "About the Crossover" (page 38).

2.2ch (3WAY) System

- 1 After selecting X-OVER from the Sound Field Adjustment mode, turn the **Rotary encoder** to select the band adjustment, and then press **Q/ENTER**.

2.2ch (3WAY) System / NORMAL (L=R)

Setting items:

LOW / MID-L / MID-H / HIGH

2.2ch (3WAY) System / INDIVIDUAL (L/R)

Setting items:

LOW-L / LOW-R / MID-L-L / MID-L-R / MID-H-L / MID-H-R / HIGH-L / HIGH-R

- 2 Turn the **Rotary encoder** to select an item to adjust, then press **Q/ENTER**.

FC → LV → SLP → FC
(cut-off frequency) (level) (slope) (frequency)

Cut-off frequency

- 3-1 Turn the **Rotary encoder** to select the desired cut-off frequency (**Crossover Point**).

Adjustable frequency bands:

2.2ch (3WAY) System

Setting items:

LOW / MID-L 20 Hz~200 Hz
MID-H 20 Hz~20 kHz
HIGH (1 kHz~20 kHz)*¹ / (20 Hz~20 kHz)*²

*¹ When **FACTORY'S** is selected, refer to "Setting the Response Slope for the High Range Speaker (TW Setup)" (page 36).

*² When **USER'S** is selected, refer to "Setting the Response Slope for the High Range Speaker (TW Setup)" (page 36).

Level Adjustment

- 3-2 Turn the **Rotary encoder** to adjust the output level.

Adjustable output level: -12 to 0 dB.

Slope Adjustment

- 3-3 Turn the **Rotary encoder** to adjust the slope.

Adjustable slope: FLAT*, 6 dB/oct., 12 dB/oct., 18 dB/oct., 24 dB/oct.

* **FLAT** can be set for the **HIGH** slope only when **USER'S** is selected in "Setting the Response Slope for the High Range Speaker (TW Setup)" (page 36). Depending on the response characteristics of the speaker, care should be taken when setting the response slope to **FLAT**, as speaker damage may result. With this unit, a message is displayed when the response slope for the high range speaker is set to **FLAT**.

- 4 Repeat steps 1 to 3 to make adjustment to the other bands.

4.2ch (FRONT/REAR/SUBW.) System

- 1 After selecting X-OVER from the Sound Field Adjustment mode, turn the **Rotary encoder** to select the band adjustment, and then press **Q/ENTER**.

4.2ch (FRONT/REAR/SUBW.) System / NORMAL (L=R)

Setting items:

LOW (SUB-W) / MID (REAR) / HIGH (FRONT)

4.2ch (FRONT/REAR/SUBW.) System / INDIVIDUAL (L/R)

Setting items:

LOW (SUB-W)-L / LOW (SUB-W)-R / MID (REAR)-L / MID (REAR)-R / HIGH (FRONT)-L / HIGH (FRONT)-R

- 2 Turn the **Rotary encoder** to select an item to adjust, then press **Q/ENTER**.

FC → LV → SLP → FC
(cut-off frequency) (level) (slope) (frequency)

Cut-off frequency

- 3-1 Turn the **Rotary encoder** to select the desired cut-off frequency (**Crossover Point**).

Adjustable frequency bands:

4.2ch (FRONT/REAR/SUBW.) System

Setting items:

20 Hz~200 Hz

Level Adjustment

- 3-2 Turn the **Rotary encoder** to adjust the output level.

Adjustable output level: -12 to 0 dB.

Slope Adjustment

- 3-3 Turn the **Rotary encoder** to adjust the slope.

Adjustable slope: FLAT, 6 dB/oct., 12 dB/oct., 18 dB/oct., 24 dB/oct.

- 4 Repeat steps 1 to 3 to make adjustment to the other bands.

- While adjusting the X-over, you should consider the frequency response of the connected speakers.
- About the 2.2ch (3WAY)/4.2ch (FRONT/REAR/SUBW.) system You can switch to 2.2ch (3WAY)/4.2ch (FRONT/REAR/SUBW.) system mode with the 2.2ch (3WAY)/4.2ch (FRONT/REAR/SUBW.) switch on the PXA-H100. For details, refer to the Owner's Manual of PXA-H100.

Turning Subwoofer ON/OFF

When the subwoofer is on, you can adjust the subwoofer output level (refer to page 20).

OFF ↔ ON (Initial setting)

Setting the Subwoofer System

When the subwoofer is on, you can select either SYS 1 or SYS 2 for the desired subwoofer effect.

SYS 1 (Initial setting) ↔ SYS 2

SYS 1 : Subwoofer level changes according to the main volume setting.

SYS 2 : Subwoofer level change is different from the main volume setting. For example, even at low volume settings, the subwoofer is still audible.

Setting the Subwoofer Phase

NORMAL (Initial setting) ↔ REVERSE

The subwoofer output phase is toggled SUBWOOFER NORMAL (0°) or SUBWOOFER REVERSE (180°). To adjust the level, turn the **Rotary encoder**.

Setting the Subwoofer Channel (SUBW CHANNEL)

You can set the subwoofer output to stereo or monaural. Make sure to set the correct output for your subwoofer type.

STEREO (Initial setting) ↔ MONO

STEREO : Subwoofer stereo (L/R) output

MONO : Subwoofer monaural output

Setting the Response Slope for the High Range Speaker (TW Setup)

Depending on the response characteristics of the speaker, care should be taken when setting the response slope of the high range speaker to FLAT in 2.2ch (3WAY) mode (see "Adjusting the Crossover Settings (X-OVER)" on page 35), as speaker damage may result.

FACTORY'S (Initial setting) ↔ USER'S

FACTORY'S : As protection from possible speaker damage, FLAT cannot be set for the response slope of the high range speaker in 2.2ch (3WAY) mode.

USER'S : The FLAT setting is possible in 2.2ch (3WAY) mode.

Setting EQ mode

This setting gives you a choice of 5-band parametric, or 7-band graphic equalizer.

PARAMETRIC (Initial setting) ↔ GRAPHIC

Setting the Filter type

NORMAL (Initial setting) ↔ INDIVIDUAL

NORMAL (L=R) : Left and right speakers are adjusted equally.

INDIVIDUAL (L/R) : Left and right speakers are individually adjusted.

Setting the Time Correction Unit (TCR Parameter)

You can change the unit, (cm or inch) of time correction.

CM (Initial setting) ↔ INCH

Setting the MX Level

MX (Media Xpander) makes vocals or instruments sound distinct regardless of the music source. The FM radio, CD, USB memory and iPhone/iPod, will be able to reproduce the music clearly.

Changing the source to which you want to apply Media Xpander.

FM (MX level 1 to 3):

This medium to high frequencies become clearer, and produces well balanced sound at all frequencies.

CD (MX level 1 to 3):

CD mode processes a large amount of data during playback. MX takes advantage of this large data quantity to reproduce a more clear, clean output.

CMPM/SAT (MX level 1 to 3):

This corrects information that was lost at the time of compression. This reproduces a well-balanced sound close to the original.

DVD (MX level 1 to 3):

A DVD or Video CD contains a large quantity of data such as music clip. MX uses this data to reproduce the sound accurately.

AUX (MX level 1 to 3):

Choose the MX mode (CMPM, MOVIE, or MUSIC) that corresponds to the media connected.

- *The initial setting of MX is different depending on the source.*
- *Each music source, such as FM radio, CD, and MP3/WMA/AAC can have its own MX setting.*
- *On discs with both MP3/WMA/AAC and CD-DA, when the source changes from "MP3/WMA/AAC to CD-DA" or "CD-DA to MP3/WMA/AAC", MX-mode switching may delay playback slightly.*
- *Setting to Non Effect sets MX mode of each music source to OFF.*
- *This function is inoperable when DEFEAT is set to ON.*
- *There is no MX mode for AM radio.*
- *If an audio processor with the MX function (PXA-H701, etc.) is connected, its own MX processing is applied to the music source. Since the processor MX settings may not match the head unit, the audio processor needs to be adjusted. For details, refer to the Owner's Manual of the audio processor.*
- *"CMPM" is applied for MP3/WMA/AAC and iPhone/iPod.*
- *"SAT" is applied for XM radio and SIRIUS radio.*

About Time Correction

The distance between the listener and the speakers in a boat vary widely due to the complex speaker placement. This difference in the distances from the speakers to the listener creates a shift in the sounds image and frequency characteristics. This is caused by the time delay between the sound reaching the listener's right versus the left ear.

To correct this, this unit is able to delay the audio signal to the speakers closest to the listener. This effectively creates a perception of increased distance for those speakers. The listener can be placed at an equal distance between the left and right speakers for optimum staging. The adjustment will be made for each speaker in 3.4cm steps.

Example 1. Listening Position: Front Left Seat

Adjust the time correction level of the front left speaker to a high value and the rear right to zero or a low value.

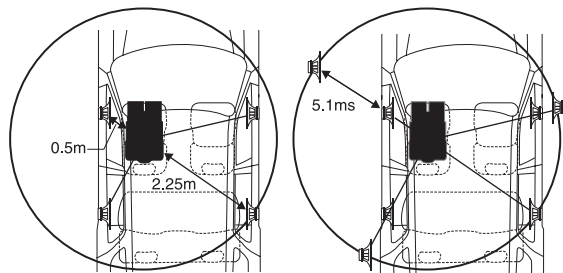

The sound is not balanced because the distance between the listening position and the various speakers is different. The difference in distance between the front left speaker and the rear right speaker is 1.75 m (68-7/8").

Here we calculate the time correction value for the front left speaker in the diagram on the above.

Conditions:

Farthest Speaker – listening position : 2.25 m (88-9/16")

Front left speaker – listening position : 0.5 m (19-11/16")

Calculation: $L = 2.25 \text{ m} - 0.5 \text{ m} = 1.75 \text{ m (68-7/8")}$

Time correction = $1.75 \div 343^{*1} \times 1,000 = 5.1 \text{ (ms)}$

**1 Speed of sound: 343 m/s (765 mph) at 20°C*

In other words, giving the front left speaker a time correction value of 5.1 ms makes it seem as if its distance from the listener is the same as the distance to the farthest speaker.

Time correction eliminates the differences in the time required for the sound to reach the listening position.

The time of the front left speaker is corrected by 5.1 ms so that its sound reaches the listening position at the same time as the sound of other speakers.

Example 2. Listening Position: All Seats

Adjust the time correction level of each speaker to almost the same level.

1 Sit in the listening position (driver's seat, etc.) and measure the distance (in meters) between your head and the various speakers.

2 Calculate the difference between the distance correction value to the farthest speaker and the other speakers.

$L = (\text{distance to farthest speaker}) - (\text{distance to other speakers})$

These values are the time correction values for the different speakers. Setting these values to make each sound reach the listening position at the same time as the sound of other speakers.

Time Correction Value List

Delay Number	Time Difference (ms)	Distance (cm)	Distance (inch)	Delay Number	Time Difference (ms)	Distance (cm)	Distance (inch)
0	0.0	0.0	0.0	51	5.1	173.4	68.3
1	0.1	3.4	1.3	52	5.2	176.8	69.7
2	0.2	6.8	2.7	53	5.3	180.2	71.0
3	0.3	10.2	4.0	54	5.4	183.6	72.4
4	0.4	13.6	5.4	55	5.5	187.0	73.7
5	0.5	17.0	6.7	56	5.6	190.4	75.0
6	0.6	20.4	8.0	57	5.7	193.8	76.4
7	0.7	23.8	9.4	58	5.8	197.2	77.7
8	0.8	27.2	10.7	59	5.9	200.6	79.1
9	0.9	30.6	12.1	60	6.0	204.0	80.4
10	1.0	34.0	13.4	61	6.1	207.4	81.7
11	1.1	37.4	14.7	62	6.2	210.8	83.1
12	1.2	40.8	16.1	63	6.3	214.2	84.4
13	1.3	44.2	17.4	64	6.4	217.6	85.8
14	1.4	47.6	18.8	65	6.5	221.0	87.1
15	1.5	51.0	20.1	66	6.6	224.4	88.4
16	1.6	54.4	21.4	67	6.7	227.8	89.8
17	1.7	57.8	22.8	68	6.8	231.2	91.1
18	1.8	61.2	24.1	69	6.9	234.6	92.5
19	1.9	64.6	25.5	70	7.0	238.0	93.8
20	2.0	68.0	26.8	71	7.1	241.4	95.1
21	2.1	71.4	28.1	72	7.2	244.8	96.5
22	2.2	74.8	29.5	73	7.3	248.2	97.8
23	2.3	78.2	30.8	74	7.4	251.6	99.2
24	2.4	81.6	32.2	75	7.5	255.0	100.5
25	2.5	85.0	33.5	76	7.6	258.4	101.8
26	2.6	88.4	34.8	77	7.7	261.8	103.2
27	2.7	91.8	36.2	78	7.8	265.2	104.5
28	2.8	95.2	37.5	79	7.9	268.6	105.9
29	2.9	98.6	38.9	80	8.0	272.0	107.2
30	3.0	102.0	40.2	81	8.1	275.4	108.5
31	3.1	105.4	41.5	82	8.2	278.8	109.9
32	3.2	108.8	42.9	83	8.3	282.2	111.2
33	3.3	112.2	44.2	84	8.4	285.6	112.6
34	3.4	115.6	45.6	85	8.5	289.0	113.9
35	3.5	119.0	46.9	86	8.6	292.4	115.2
36	3.6	122.4	48.2	87	8.7	295.8	116.6
37	3.7	125.8	49.6	88	8.8	299.2	117.9
38	3.8	129.2	50.9	89	8.9	302.6	119.3
39	3.9	132.6	52.3	90	9.0	306.0	120.6
40	4.0	136.0	53.6	91	9.1	309.4	121.9
41	4.1	139.4	54.9	92	9.2	312.8	123.3
42	4.2	142.8	56.3	93	9.3	316.2	124.6
43	4.3	146.2	57.6	94	9.4	319.6	126.0
44	4.4	149.6	59.0	95	9.5	323.0	127.3
45	4.5	153.0	60.3	96	9.6	326.4	128.6
46	4.6	156.4	61.6	97	9.7	329.8	130.0
47	4.7	159.8	63.0	98	9.8	333.2	131.3
48	4.8	163.2	64.3	99	9.9	336.6	132.7
49	4.9	166.6	65.7				
50	5.0	170.0	67.0				

About the Crossover

Crossover (X-OVER):

This unit is equipped with an active crossover. The crossover limits the frequencies delivered to the outputs. Each channel is controlled independently. Thus, each speaker pair can be driven by the frequencies for which they have been optimally designed.

The crossover adjusts the HPF (high pass filter) or LPF (low pass filter) of each band, and also the slope (how fast the filter rolls off the highs or lows).

Adjustments should be made according to the reproduction characteristics of the speakers. Depending on the speakers, a passive network may not be necessary. If you are unsure about this point, please consult your authorized Alpine dealer.

4.2ch (FRONT/REAR/SUB.W.) mode

	Cut-off frequency (1/3 octave steps)		Slope		Level
	HPF	LPF	HPF	LPF	
Low range speaker	----	20 Hz - 200 Hz	----	FLAT, 6, 12, 18, 24 dB/oct.	0 to -12 dB
Rear high range speaker	20 Hz - 200 Hz	----	FLAT, 6, 12, 18, 24 dB/oct.	----	0 to -12 dB
Front high range speaker	20 Hz - 200 Hz	----	FLAT, 6, 12, 18, 24 dB/oct.	----	0 to -12 dB

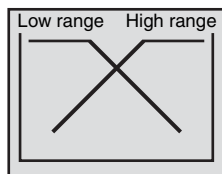

(Different from actual display)

2.2ch (3WAY) mode

	Cut-off frequency (1/3 octave steps)		Slope		Level
	HPF	LPF	HPF	LPF	
Low range speaker	----	20 Hz - 200 Hz	----	FLAT, 6, 12, 18, 24 dB/oct.	0 to -12 dB
Mid range speaker	20 Hz - 200 Hz	20 Hz - 20 kHz	FLAT, 6, 12, 18, 24 dB/oct.	FLAT, 6, 12, 18, 24 dB/oct.	0 to -12 dB
High range speaker	1 kHz - 20 kHz, (20 Hz ~ 20 kHz)*	----	FLAT* 6, 12, 18, 24 dB/oct.	----	0 to -12 dB

* Only when selecting USER'S in "Setting the Response Slope for the High Range Speaker (TW Setup)" (page 36).

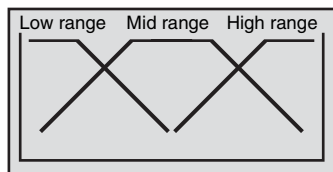

(Different from actual display)

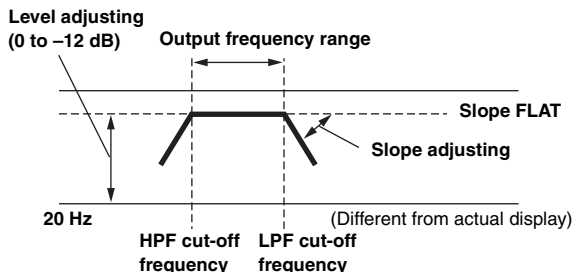

- **HPF (high pass filter):** Cuts the lower frequencies and allows the higher frequencies to pass.
 - **LPF (low pass filter):** Cuts the higher frequencies and allows the lower frequencies to pass.
 - **Slope:** The level change (in dB) for a frequency change of one octave.
 - The higher the slope value, the steeper the slope becomes.
 - Adjust the slope to FLAT to bypass the HP or LP filters.
 - Do not use a tweeter without the HPF on or set to a low frequency, as it may cause damage to the speaker due to the low frequency content.
 - You cannot adjust the crossover frequency higher than the HPF or lower than the LPF.
 - Adjustment should be made according to the recommended crossover frequency of the connected speakers. Determine the recommended crossover frequency of the speakers. Adjusting to a frequency range outside that recommended may cause damage to the speakers. For the recommended crossover frequencies of Alpine speakers, refer to the respective Owner's Manual.
- We are not responsible for damage or malfunction of speakers caused by using the crossover outside the recommended value.

Changer (Optional)

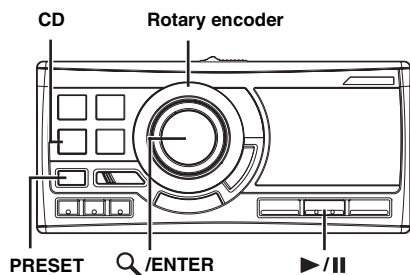

Selecting a Disc (Changer) (Optional)

An optional 6-disc or 12-disc CD Changer may be connected to this unit if it is Ai-NET compatible. With a CD Changer connected to the Ai-NET input of this unit, the CD Changer will be controllable from this unit.

Using the KCA-410C (Versatile Link Terminal) multiple changers can be controlled by this unit.

See “Multi-Changer Selection (Optional)” on page 39 for selecting the CD Changers.

- The controls on this unit for CD Changer operation are operative only when a CD Changer is connected.
- The DVD changer (optional) is controllable from this unit as well as the CD changer.

- 1 Press CD to switch to the CD Changer mode.**
- 2 Press and hold PRESET for at least 2 seconds.**
The DISC CHANGE screen is displayed.
- 3 Turn the Rotary encoder to select a disc.**
- 4 Press Q/ENTER.**
The selected disc number appears in the display and CD/MP3/WMA/AAC playback starts.

- You can also switch the DISC by pressing **PRESET**.

Playing MP3 Files with the CD Changer (Optional)

If you connect a changer compatible with MP3, you can play CD-ROMs, CD-Rs, and CD-RWs containing MP3 files on this unit.

- 1 Press CD to switch to the MP3 Changer mode.**
- 2 Press PRESET to select the desired disc.**
- 3 To pause playback, press ►/II .**
Pressing ►/II again will resume playback.

- The unit can play discs containing both audio data and MP3 data.
- For operating MP3 with an MP3 compatible CD Changer, refer to “CD/MP3/WMA/AAC” page 10 to 14.

Multi-Changer Selection (Optional)

When using KCA-410C (Versatile Link Terminal), you can connect two changers and two external outputs (AUX).

Press CD until the desired CD Changer appears on the display.

- If the CD Changer is not connected, the display will show “NO CHANGER”.
- To operate the selected changer, see “CD/MP3/WMA/AAC” (page 10 to 14).
- For further details about the external input (AUX) when using KCA-410C, see “Setting the AUX Mode (V-Link)” on page 25.

Information

In Case of Difficulty

If you encounter a problem, please turn the power off, then on again. If the unit is still not functioning normally, please review the items in the following checklist. This guide will help you isolate the problem if the unit is at fault. Otherwise, make sure the rest of your system is properly connected or consult your authorized Alpine dealer.

Basic

No function or display.

- Boat's ignition or radio switch is off.
 - If connected following instructions, the unit will not operate with the boat's ignition or radio switch off.
- Improper power lead (Red) and battery lead (Yellow) connections.
 - Check power lead and battery lead connections.
- Blown fuse.
 - Check the fuse of the unit; replace with the proper value if necessary.
- Internal micro-computer malfunctioned due to interference noise etc.
 - Press the RESET switch with a ball-point pen or other pointed article.

Radio

Unable to receive stations.

- No antenna or open connection in cable.
 - Make sure the antenna is properly connected; replace the antenna or cable if necessary.

Unable to tune stations in the seek mode.

- You are in a weak signal area.
 - Make sure the tuner is in the DX mode.
- If the area you are in is a primary signal area, the antenna may not be grounded and connected properly.
 - Check your antenna connections; make sure the antenna is properly grounded at its mounting location.
- The antenna may not be the proper length.
 - Make sure the antenna is fully extended; if broken, replace the antenna with a new one.

Broadcast is noisy.

- The antenna is not the proper length.
 - Extend the antenna fully; replace it if it is broken.
- The antenna is poorly grounded.
 - Make sure the antenna is grounded properly at its mounting location.

CD

CD Player/Changer not functioning.

- Out of operating temperature range +50°C (+120°F) for CD.
 - Allow the boat's interior (or trunk) temperature to cool.

CD playback sound is wavering.

- Moisture condensation in the CD Module.
 - Allow enough time for the condensation to evaporate (about 1 hour).

CD insertion not possible.

- A CD is already in the CD player.
 - Eject the CD and remove it.
- The CD is being improperly inserted.
 - Make sure the CD is being inserted following instructions in the CD Player Operation section.

Unable to fast forward or backward the CD.

- The CD has been damaged.
 - Eject the CD and discard it; using a damaged CD in your unit can cause damage to the mechanism.

CD playback sound skips due to vibration.

- Improper mounting of the unit.
 - Securely re-mount the unit.
- The disc is very dirty.
 - Clean the disc.
- The disc has scratches.
 - Change the disc.
- The pick-up lens is dirty.
 - Do not use a commercially available lens cleaner disc. Consult your nearest Alpine dealer.

CD playback sound skips without vibration.

- The disc is dirty or scratched.
 - Clean the disc; damaged disc should be replaced.

Error displays (built-in CD player only).

- Mechanical error.
 - Press ▲. After the error indication disappears, insert the disc again. If the above-mentioned solution does not solve the problem, consult your nearest Alpine dealer.

CD-R/CD-RW playback not possible.

- Close session (finalization) has not been performed.
 - Perform finalization and attempt playback again.

MP3/WMA/AAC

MP3, WMA or AAC is not played back.

- Writing error occurred. The CD format is not compatible.
 - Make sure the CD has been written in a supported format. Refer to "About MP3/WMA/AAC" (page 13), then rewrite in the format supported by this device.

Audio

The sound is not output from the speakers.

- There is no signal output from the internal amplifier.
 - POWER IC is switched to "OFF" (page 25).

iPod

iPod does not play and no sound is output.

- The iPod has not been recognized.
 - Reset this unit and the iPod. Refer to "Initial System Start-Up" (page 7). To reset the iPod, refer to the Owner's Manual of the iPod.

Indication for CD Player

NO DISC

- No CD is inserted.
 - Insert a CD.
- Although a disc is inserted, "NO DISC" is displayed and the unit does not start to play or eject the disc.
 - Remove the disc by following these steps:
 - Press the **▲** button again for at least 2 seconds.
 - If the disc still does not eject, consult your Alpine dealer.

ERROR

- Mechanism error.
 - 1) Press the **▲** button and eject the CD.
 - If not ejecting, consult your Alpine dealer.
 - 2) When the error indication remains after ejecting, press the **▲** button again.
 - If the error indication still does not turn off after pressing the **▲** button for a few times, consult your Alpine dealer.
- When "ERROR" is displayed:
 - If the disc cannot be ejected by pressing **▲**, press the RESET switch (refer to page 7) and press **▲** again.
 - If the disc still cannot be ejected, consult your Alpine dealer.

PROTECT

- A copy-protected WMA file was played back.
 - You can only play back non-copy-protected files.

UNSUPPORT

- A sampling rate/bit rate not supported by the unit is used.
 - Use a sampling rate/bit rate that is supported by the unit.

Indication for CD Changer

HI-TEMP

- Protective circuit is activated due to high temperature.
 - The indication will disappear when the temperature returns to normal operating range.

ERROR-01

- Malfunction in the CD Changer.
 - Consult your Alpine dealer. Press the magazine eject button and pull out the magazine. Check the indication. Insert the magazine again. If the magazine cannot be pulled out, consult your Alpine dealer.
- Magazine ejection not possible.
 - Press the magazine eject button. If the magazine does not eject, consult your Alpine dealer.

ERROR-02

- A disc is left inside the CD Changer.
 - Press the eject button to activate the eject function. When the CD Changer finishes the eject function, insert an empty CD magazine into the CD Changer to receive the disc left inside the CD Changer.

NO MAGAZINE

- No magazine is loaded into the CD Changer.
 - Insert a magazine.

NO DISC

- No indicated disc.
 - Choose another disc.

Indication for iPod Mode

CURRENT ERROR

- Abnormal current is run to the USB connector device.
 - You can solve the problem by switching the source, turning the unit power off, or ACC to the OFF position.
-

DEVICE ERROR

- A USB device that is not supported by the unit is connected.
 - Connect a USB device that is supported by the unit.
-

NO USB DEVICE

- An iPhone/iPod is not connected.
 - Make sure the iPhone/iPod is correctly connected and the cable is not excessively bent.
-

NO SONG

- There are no songs in the iPhone/iPod.
 - Download songs to the iPhone/iPod and connect to this unit.
-

ERROR-01

- Communication error
 - Turn the ignition key off, and then set to ON again.
 - Check the display by reconnecting between the iPhone/iPod and this unit, using the iPod cable.
-

ERROR-02

- Caused by the iPhone/iPod Software Version not being compatible with this unit.
 - Update the iPhone/iPod Software Version to be compatible with this unit.
-

ERROR-03

- The iPhone/iPod is not verified.
 - Change another iPhone/iPod.
-

Indication for USB memory

CURRENT ERROR

- Abnormal current is run to the USB connector device.
 - You can solve the problem by switching the source, turning the unit power off, or ACC to the OFF position.
-

DEVICE ERROR

- A USB device that is not supported by the unit is connected.
 - Connect a USB device that is supported by the unit.
-

NO USB DEVICE

- A USB memory is not connected.
 - Make sure the USB memory device is correctly connected and the cable is not excessively bent.
-

NO FILE

- No song (file) is stored in the USB memory.
 - Connect the USB memory device after storing songs (files).
-

UNSUPPORT

- A sampling rate/bit rate not supported by the unit is used.
 - Use a sampling rate/bit rate that is supported by the unit.
-

PROTECT

- A copy-protected WMA file was played back.
 - You can only play back non-copy-protected files.
-

ERROR-01

- Communication error
 - Turn the ignition key OFF, and then set to ON again.
-

Indication for SAT Receiver Mode

XM TUNER

(XM mode)

- MiniTuner missing/disconnected or no communication between the unit and XM Radio.
 - Check the XM Tuner.
-

ANTENNA

- The XM or SIRIUS antenna is not connected to the XM or SIRIUS radio module.
 - Check whether the XM or SIRIUS antenna cable is attached securely to the XM or SIRIUS radio module.
-

UPDATING

(SIRIUS mode)

- The Receiver is updating the SIRIUS channel line up. During update, audio will be muted until update is completed.
 - Wait until the channel update is completed. After completion, the unit automatically re-tune to previous channel.
-

FW UPDT

(SIRIUS mode)

- Radio's firmware is being updated. During firmware update, audio will be muted until update is completed.
 - Wait until the update is completed. After completion, automatically re-tune to previous channel.
-

SUB UPDT

(Blink) (SIRIUS mode)

- The subscribed program is being updated. During update, audio will be muted until update is completed.
 - Wait until the update is completed. After completion, follow the indication "SUB UPDT" to press any key on the unit to continue, the unit re-tune to previous channel.
-

NO SIGNAL

(XM mode)

LINKING

(SIRIUS mode)

- XM or SIRIUS signal is too weak at the current location.
 - Wait until the boat reaches a location with a stronger signal.
-

LOADING

(XM mode)

- Radio is acquiring audio or program information.
 - Wait until the radio has received the information.
-

OFF AIR

(XM mode)

- The channel currently selected has stopped broadcasting.
 - Select another channel.
-

CH UNAVL

(XM mode)

INVALID

(SIRIUS mode)

- The user has selected a channel number that does not exist.
 - The unit will revert back to the previously selected channel.
-

UNAUTH

(XM mode)

- The user has selected a channel number that does not exist.
 - The unit will revert to the previous selected channel or to channel 1 automatically.
-

Specifications

FM TUNER SECTION

Tuning Range	87.7-107.9 MHz (MODE1) 87.50-108.00 MHz (MODE2)
Mono Usable Sensitivity	9.3 dBf (0.8µV/75 ohms)
50 dB Quieting Sensitivity	13.5 dBf (1.3µV/75 ohms)
Alternate Channel Selectivity	80 dB
Signal-to-Noise Ratio	65 dB
Stereo Separation	35 dB
Capture Ratio	2.0 dB

AM TUNER SECTION

Tuning Range	530-1,710 kHz (MODE1) 531-1,602 kHz (MODE2)
Sensitivity (IEC Standard)	22.5 µV/27 dB

CD PLAYER SECTION

Frequency Response	5-20,000 Hz (±1 dB)
Wow & Flutter (% WRMS)	Below measurable limits
Total Harmonic Distortion	0.008% (at 1 kHz)
Dynamic Range	95 dB (at 1 kHz)
Signal-to-Noise Ratio	105 dB
Channel Separation	85 dB (at 1 kHz)

USB SECTION

USB requirements	USB 1.1/2.0
Max. Power Consumption	500mA
USB Class	Mass Storage
File System	FAT 12/16/32
MP3 Decoding	MPEG-1/2 AUDIO Layer-3
WMA Decoding	Windows Media™ Audio
AAC Decoding	AAC-LC format “.m4a” file
Number of Channels	2-Channel (Stereo)
Frequency Response*	5-20,000 Hz (±1 dB)
Total Harmonic Distortion	0.008% (at 1 kHz)
Dynamic Range	95 dB (at 1 kHz)
Signal-to-Noise Ratio	>105 dB
Channel Separation	85 dB (at 1 kHz)

* Frequency response may differ depending on the encoder software/bit rate.

PICKUP

Wave length	795 nm
Laser power	CLASS I

GENERAL

Power Requirement	14.4 V DC (11-16 V allowable)
-------------------	----------------------------------

Power Output	18 W RMS × 4*
--------------	---------------

*Primary amplifier ratings per CEA-2006 Standard

- Power output: measured at 4 Ohms and ≤ 1% THD+N
- S/N: 80 dBA (reference: 1 W into 4 Ohms)

Maximum Pre-Output Voltage	2 V/10 k ohms
Bass	±14 dB at 100 Hz
Treble	±14 dB at 10 kHz
Weight	2.0 kg (4 lbs. 6 oz)

CHASSIS SIZE

Width	181.5 mm (7-3/16")
Height	51.5 mm (2-1/16")
Depth	187 mm (7-3/8")

NOSEPIECE SIZE

Width	200 mm (7-7/8")
Height	92.5 mm (3-5/8")
Depth	50 mm (2")

- *Due to continuous product improvement, specifications and design are subject to change without notice.*

Installation and Connections

Before installing or connecting the unit, please read the following and page 4 of this manual thoroughly for proper use.

Warning

MAKE THE CORRECT CONNECTIONS.

Failure to make the proper connections may result in fire or product damage.

DO NOT CONNECT A POWER SUPPLY OTHER THAN A DC 12V NEGATIVE GROUND TYPE.

Failure to do so may result in accident or fire.

BEFORE WIRING, DISCONNECT THE CABLE FROM THE NEGATIVE BATTERY TERMINAL.

Failure to do so may result in electric shock or injury due to electrical shorts.

DO NOT SPLICE INTO ELECTRICAL CABLES.

Never cut away cable insulation to supply power to other equipment. Doing so will exceed the current carrying capacity of the wire and result in fire or electric shock.

DO NOT DAMAGE PIPE OR WIRING WHEN DRILLING HOLES.

When drilling holes in the hull for installation, take precautions so as not to contact, damage or obstruct pipes, fuel lines, tanks or electrical wiring. Failure to take such precautions may result in fire.

KEEP SMALL OBJECTS SUCH AS BOLTS OR SCREWS OUT OF THE REACH OF CHILDREN.

Swallowing them may result in serious injury. If swallowed, consult a physician immediately.

DO NOT INSTALL IN LOCATIONS WHICH MIGHT HINDER BOAT OPERATION, SUCH AS THE STEERING WHEEL OR THROTTLE CONTROLS.

Doing so may obstruct forward vision or hamper movement etc. and results in serious accident.

DO NOT ALLOW CABLES TO BECOME ENTANGLED IN SURROUNDING OBJECTS.

Arrange wiring and cables in compliance with the manual to prevent obstructions when driving. Cables or wiring that obstruct or hang up on places such as the steering wheel, throttle controls, etc. can be extremely hazardous.

Caution

HAVE THE WIRING AND INSTALLATION DONE BY EXPERTS.

The wiring and installation of this unit requires special technical skill and experience. To ensure safety, always contact the dealer where you purchased this product to have the work done.

USE SPECIFIED ACCESSORY PARTS AND INSTALL THEM SECURELY.

Be sure to use only the specified accessory parts. Use of other than designated parts may damage this unit internally or may not securely install the unit in place. This may cause parts to become loose resulting in hazards or product failure.

ARRANGE THE WIRING SO IT IS NOT CRIMPED OR PINCHED BY A SHARP METAL EDGE.

Route the cables and wiring away from moving parts (like the hatch covers or engine covers) or sharp or pointed edges. This will prevent crimping and damage to the wiring. If wiring passes through a hole in metal, use a rubber grommet to prevent the wire's insulation from being cut by the metal edge of the hole.

DO NOT INSTALL IN LOCATIONS WITH HIGH MOISTURE OR DUST.

Avoid installing the unit in locations with high incidence of moisture or dust. Moisture or dust that penetrates into this unit may result in product failure.

Precautions

- Be sure to disconnect the cable from the (–) battery post before installing your CDA-118M. This will reduce any chance of damage to the unit in case of a short-circuit.
- Be sure to connect the color coded leads according to the diagram. Incorrect connections may cause the unit to malfunction or damage to the boat's electrical system.
- When making connections to the boat's electrical system, be aware of the factory installed components (e.g. on-board computer). Do not tap into these leads to provide power for this unit. When connecting the CDA-118M to the fuse box, make sure the fuse for the intended circuit of the CDA-118M has the appropriate amperage. Failure to do so may result in damage to the unit and/or the boat. When in doubt, consult your Alpine dealer.
- The CDA-118M uses female RCA-type jacks for connection to other units (e.g. amplifier) having RCA connectors. You may need an adaptor to connect other units. If so, please contact your authorized Alpine dealer for assistance.
- Be sure to connect the speaker (–) leads to the speaker (–) terminal. Never connect left and right channel speaker cables to each other or to the boat body.

IMPORTANT

Please record the serial number of your unit in the space provided below and keep it as a permanent record. The serial number or the engraved serial number is located on the bottom of the unit.

SERIAL NUMBER: _____

INSTALLATION DATE: _____

INSTALLATION TECHNICIAN: _____

PLACE OF PURCHASE: _____

Installation

Caution

Do not block the unit's heat sink, thus preventing air circulation. If blocked, heat will accumulate inside the unit and may cause a fire.

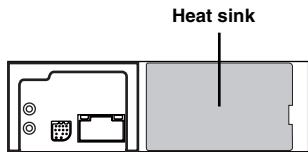

- The main unit must be mounted within 30 degrees of the horizontal plane, back to front.

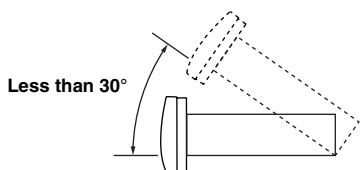

- Stick the Installation Template to a chosen mounting location, and drill holes according to the Installation Template's indication.
- Open the front panel, and install the unit as show below.

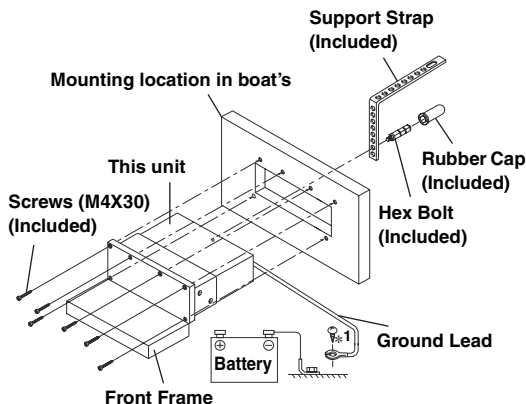

Reinforce the head unit with the support strap. Secure the ground to a wire attached directly to the boat's negative battery terminal.

- For the screw marked "※", use an appropriate screw for the chosen mounting location.

Connect each input lead coming from an amplifier or equalizer to the corresponding output lead coming from the left rear of the CDA-118M. Connect all other leads of the CDA-118M according to details described in the CONNECTIONS section.

- Close the front panel.

iPhone/iPod Connection (sold separately)

Connect USB cable to an iPhone/iPod with Interface cable for iPod.

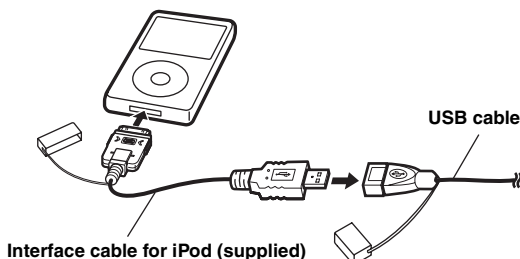

Remove the iPhone/iPod

Remove the iPhone/iPod from Interface cable for iPod.

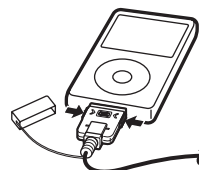

- Remove the iPhone/iPod after the unit has been changed to a source other than the iPhone/iPod. If the iPhone/iPod is removed while playing, data may be lost.
- If sound is not output or the iPhone/iPod is not recognized even when the iPhone/iPod is connected, remove the iPhone/iPod once, then connect it again, or reset the iPod.
- Do not leave the iPhone/iPod in a boat for a long time. Heat and humidity may damage the iPhone/iPod and you may not be able to play it again.

USB memory Connection (sold separately)

Connect USB memory

Connect the USB cable to the USB connector of the unit, and then secure the connection using the lock case supplied with USB cable as shown below.

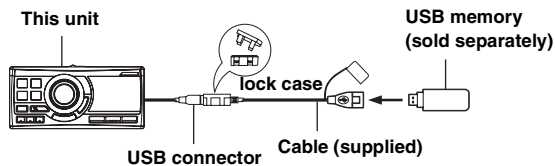

Remove USB memory

Pull out USB memory squarely from the USB cable.

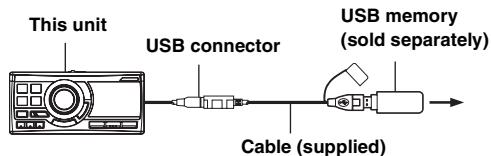

- When removing USB memory, pull it out straight.
- If sound is not output or USB memory is not recognized even when USB memory is connected, remove USB memory once, then connect it again.
- Change to a source other than the USB memory mode, then remove the USB memory. If the USB memory is removed in the USB memory mode, data may be damaged.
- Route the USB cable away from other cables.

Connections

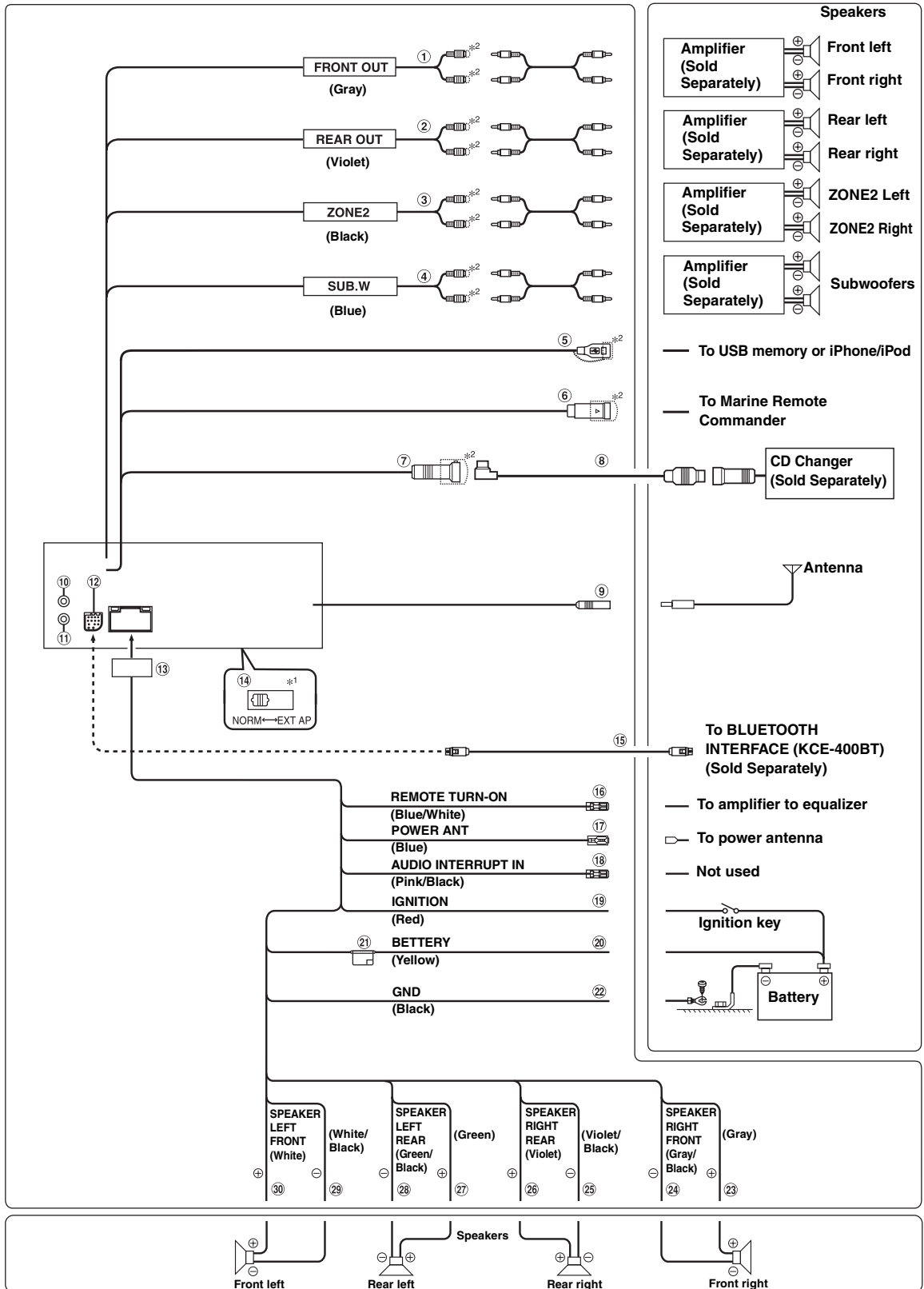

*1 The system switch is located on the bottom of the unit. Before adjusting the switch, take the rubber cover off first.

*2 Before connecting an amplifier, changer, etc., please remove the waterproof cap.

- ① **Front Output/Input RCA Connectors**
It can be used as Front Output or Input RCA Connectors.
- ② **Rear Output/Input RCA Connectors**
It can be used as Rear Output or Input RCA Connectors.
- ③ **ZONE2 Output RCA Connectors**
- ④ **Subwoofer Output RCA Connectors**
- ⑤ **USB Connector**
Connect this to an USB memory or to an iPhone/iPod. To use an iPhone/iPod, Interface cable for iPod connection is required.
- Use the supplied USB cable. If a USB cable other than the supplied is used, correct performance cannot be guaranteed.
 - Route the USB cable away from other cables.
- ⑥ **Marine Remote Commander Connector**
This connector is used to connect the Marine Remote Commander (sold separately).
For details about connections, consult your nearest Alpine dealer.
- ⑦ **Ai-NET Connector**
Connect this to the output or input connector of another device (CD Changer, Equalizer, HD Radio TUNER MODULE, etc.) equipped with Ai-NET.
- Be sure to set "Setting the Connected Head Unit (MODEL SETUP)" to "CD CHG", when the DHA-S690 is connected.
 - Interface adapter for iPod (KCA-420i) is not recommended for use with this product.
 - You can input TV/video sound by connecting an optional Ai-NET/RCA Interface cable (KCA-121B) to this component.
- ⑧ **Ai-NET Cable (Included with CD Changer)**
- ⑨ **Antenna Receptacle**
- ⑩ **AUX Input Terminal**
This terminal allows for input of audio from an external device (such as a portable player), using a commercially available converter cable. Refer to "Setting the AUX ZONE Mode" (page 24).
- ⑪ **Steering Remote Control Interface Connector**
To Marine Remote Commander (sold separately).
For details about connections, consult your nearest Alpine dealer.
- ⑫ **BLUETOOTH interface connector**
Connect this to an optional BLUETOOTH INTERFACE (KCE-400BT). To use a hands-free mobile phone, an optional BLUETOOTH INTERFACE (KCE-400BT) connection is required. For details on connection, refer to the Owner's Manual of the BLUETOOTH INTERFACE (KCE-400BT).
You can also connect this to an external device (such as a portable player) by using Conversion cable (KCE-237B) for building up the AUX IN (sold separately).
- Refer to "Setting the AUX+ Mode" (page 24).
AUX+ ON : When the external device is connected.
AUX+ OFF : When set to OFF, AUX+ source cannot be selected.
- ⑬ **Power Supply Connector**
- ⑭ **System Switch**
When connecting a processor or divider using Ai-NET, place this switch in the EXT AP position. When no device is connected, leave the switch in the NORM position.
When switched to NORM, the RCA Connectors ① and ② can be used as Output RCA Connectors.
When switched to EXT AP, the RCA Connectors ① and ② can be used as Input RCA Connectors.
- Be sure to turn the power off to the unit before changing the switch position.
- ⑮ **KCE-400BT Connection Cable (Included with KCE-400BT)**
- ⑯ **Remote Turn-On Lead (Blue/White)**
Connect this lead to the remote turn-on lead of your amplifier or signal processor.
- ⑰ **Power Antenna Lead (Blue)**
Connect this lead to the +B terminal of your power antenna, if applicable.
- This lead should be used only for controlling the boat's power antenna. Do not use this lead to turn on an amplifier, or a signal processor, etc.
- ⑱ **Audio Interrupt In Lead (Pink/Black)**
- ⑲ **Switched Power Lead (Ignition) (Red)**
Connect this lead to an open terminal on the boat's fuse box or another unused power source which provides (+)12V only when the ignition is turned on or in the accessory position.
- ⑳ **Battery Lead (Yellow)**
Connect this lead to the positive (+) post of the boat's battery.
- ㉑ **Fuse Holder (10A)**
- ㉒ **Ground Lead (Black)**
Connect this lead to a wire connected directly to the boat's negative battery terminal.
- ㉓ **Right Front (+) Speaker Output Lead (Gray)**
- ㉔ **Right Front (-) Speaker Output Lead (Gray/Black)**
- ㉕ **Right Rear (-) Speaker Output Lead (Violet/Black)**
- ㉖ **Right Rear (+) Speaker Output Lead (Violet)**
- ㉗ **Left Rear (+) Speaker Output Lead (Green)**
- ㉘ **Left Rear (-) Speaker Output Lead (Green/Black)**
- ㉙ **Left Front (-) Speaker Output Lead (White/Black)**
- ㉚ **Left Front (+) Speaker Output Lead (White)**



LIMITED WARRANTY

ALPINE ELECTRONICS OF AMERICA, INC. AND ALPINE OF CANADA INC. ("Alpine"), are dedicated to quality craftsmanship and are pleased to offer this Warranty. We suggest that you read it thoroughly. Should you have any questions, please contact your Dealer or contact Alpine at one of the telephone numbers listed below.

● PRODUCTS COVERED:

This Warranty covers Audio Products and Related Accessories ("the product"). Products purchased in the Canada are covered only in the Canada. Products purchased in the U.S.A. are covered only in the U.S.A.

● LENGTH OF WARRANTY:

This Warranty is in effect for one year from the date of the first consumer purchase.

● WHO IS COVERED:

This Warranty only covers the original purchaser of the product, who must reside in the United States, Puerto Rico or Canada.

● WHAT IS COVERED:

This Warranty covers defects in materials or workmanship (parts and labor) in the product.

● WHAT IS NOT COVERED:

This Warranty does not cover the following:

- ① Damage occurring during shipment of the product to Alpine for repair (claims must be presented to the carrier).
- ② Damage caused by accident or abuse, including burned voice coils caused by over-driving the speaker (amplifier level is turned up and driven into distortion or clipping). Speaker mechanical failure (e.g. punctures, tears or rips). Cracked or damaged LCD panels. Dropped or damaged hard drives.
- ③ Damage caused by negligence, misuse, improper operation or failure to follow instructions contained in the Owner's manual.
- ④ Damage caused by act of God, including without limitation, earthquake, fire, flood, storms or other acts of nature. Any cost or expense related to the removal or reinstallation of the product.
- ⑤ Service performed by an unauthorized person, company or association.
- ⑥ Any product which has the serial number defaced, altered or removed.
- ⑦ Any product which has been adjusted, altered or modified without Alpine's consent.
- ⑧ Any product not distributed by Alpine within the United States, Puerto Rico or Canada.
- ⑨ Any product not purchased from an Authorized Alpine Dealer.

● HOW TO OBTAIN WARRANTY SERVICE:

- ① You are responsible for delivery of the product to an Authorized Alpine Service Center or Alpine for repair and for payment of any initial shipping charges. Alpine will, at its option, repair or replace the product with a new or reconditioned product without charge. If the repairs are covered by the warranty, and if the product was shipped to an Authorized Alpine Service Center or Alpine, Alpine will pay the return shipping charges.
- ② You should provide a detailed description of the problem(s) for which service is required.

- ③ You must supply proof of your purchase of the product.
- ④ You must package the product securely to avoid damage during shipment. To prevent lost packages it is recommended to use a carrier that provides a tracking service.

● HOW WE LIMIT IMPLIED WARRANTIES:

ANY IMPLIED WARRANTIES INCLUDING FITNESS FOR USE AND MERCHANTABILITY ARE LIMITED IN DURATION TO THE PERIOD OF THE EXPRESS WARRANTY SET FORTH ABOVE AND NO PERSON IS AUTHORIZED TO ASSUME FOR ALPINE ANY OTHER LIABILITY IN CONNECTION WITH THE SALE OF THE PRODUCT.

● HOW WE EXCLUDE CERTAIN DAMAGES:

ALPINE EXPRESSLY DISCLAIMS LIABILITY FOR INCIDENTAL AND CONSEQUENTIAL DAMAGES CAUSED BY THE PRODUCT. THE TERM "INCIDENTAL DAMAGES" REFERS TO EXPENSES OF TRANSPORTING THE PRODUCT TO THE ALPINE SERVICE CENTER, LOSS OF THE ORIGINAL PURCHASER'S TIME, LOSS OF THE USE OF THE PRODUCT, BUS FARES OR OTHERS COSTS RELATING TO THE CARE AND CUSTODY OF THE PRODUCT. THE TERM "CONSEQUENTIAL DAMAGES" REFERS TO THE COST OF REPAIRING OR REPLACING OTHER PROPERTY WHICH IS DAMAGED WHEN THIS PRODUCT DOES NOT WORK PROPERLY. THE REMEDIES PROVIDED UNDER THIS WARRANTY ARE EXCLUSIVE AND IN LIEU OF ALL OTHERS.

● HOW STATE/PROVINCIAL LAW RELATES TO THE WARRANTY:

This Warranty gives you specific legal rights, and you may also have other rights which vary from state to state and province to province. In addition, some states/provinces do not allow limitations on how long an implied warranty lasts, and some do not allow the exclusion or limitation of incidental or consequential damages. Accordingly, limitations as to these matters contained herein may not apply to you.

● IN CANADA ONLY:

This Warranty is not valid unless your Alpine audio product has been installed in your boat by an Authorized Installation Center, and this warranty stamped upon installation by the installation center.

● HOW TO CONTACT CUSTOMER SERVICE:

Should the product require service, please call the following number for your nearest Authorized Alpine Service Center.

AUDIO	1-800-ALPINE-1 (1-800-257-4631)
NAVIGATION	1-888-NAV-HELP (1-888-628-4357)

Or visit our website at; <http://www.alpine-usa.com>

ALPINE ELECTRONICS OF AMERICA, INC., 19145 Gramercy Place, Torrance, California 90501, U.S.A.

ALPINE ELECTRONICS OF CANADA, INC., 777 Supertest Road, Toronto, Ontario M3J 2M9, Canada

Do not send products to these addresses.

Call the toll free telephone number or visit the website to locate a service center.