

SONY®

Cyber-shot

Digital Still Camera

Instruction Manual

DSC-T300

GB



For details on advanced operations, please read **“Cyber-shot Handbook” (PDF)** and **“Cyber-shot Step-up Guide”** on the CD-ROM (supplied) using a computer.

Operating Instructions

Before operating the unit, please read this manual thoroughly, and retain it for future reference.

Owner's Record

The model and serial numbers are located on the bottom. Record the serial number in the space provided below. Refer to these numbers whenever you call upon your Sony dealer regarding this product.

Model No. DSC-T300

Serial No. _____

WARNING

To reduce fire or shock hazard, do not expose the unit to rain or moisture.

For Customers in the U.S.A.

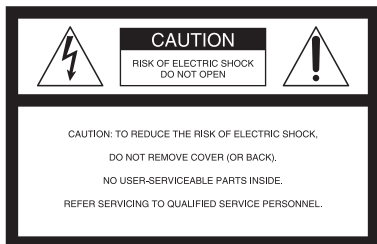

This symbol is intended to alert the user to the presence of uninsulated "dangerous voltage" within the product's enclosure that may be of sufficient magnitude to constitute a risk of electric shock to persons.



This symbol is intended to alert the user to the presence of important operating and maintenance (servicing) instructions in the literature accompanying the appliance.

IMPORTANT SAFEGUARDS

For your protection, please read these safety instructions completely before operating the appliance, and keep this manual for future reference.

Carefully observe all warnings, precautions and instructions on the appliance, or the one described in the operating instructions and adhere to them.

Use

Power Sources

This set should be operated only from the type of power source indicated on the marking label. If you are not sure of the type of electrical power supplied to your home, consult your dealer or local power company. For those sets designed to operate from battery power, or other sources, refer to the operating instructions.

Polarization

This set may be equipped with a polarized ac power cord plug (a plug having one blade wider than the other).

This plug will fit into the power outlet only one way. This is a safety feature. If you are unable to insert the plug fully into the outlet, try reversing the plug. If the plug should still fail to fit, contact your electrician to have a suitable outlet installed. Do not defeat the safety purpose of the polarized plug by forcing it in.

Overloading

Do not overload wall outlets, extension cords or convenience receptacles beyond their capacity, since this can result in fire or electric shock.

Object and Liquid Entry

Never push objects of any kind into the set through openings as they may touch dangerous voltage points or short out parts that could result in a fire or electric shock. Never spill liquid of any kind on the set.

Attachments

Do not use attachments not recommended by the manufacturer, as they may cause hazards.

Cleaning

Unplug the set from the wall outlet before cleaning or polishing it. Do not use liquid cleaners or aerosol cleaners. Use a cloth lightly dampened with water for cleaning the exterior of the set.

Installation

Water and Moisture

Do not use power-line operated sets near water – for example, near a bathtub, washbowl, kitchen sink, or laundry tub, in a wet basement, or near a swimming pool, etc.

Power-Cord Protection

Route the power cord so that it is not likely to be walked on or pinched by items placed upon or against them, paying particular attention to the plugs, receptacles, and the point where the cord exits from the appliance.

Accessories

Do not place the set on an unstable cart, stand, tripod, bracket, or table. The set may fall, causing serious injury to a child or an adult, and serious damage to the set. Use only a cart, stand, tripod, bracket, or table recommended by the manufacturer.

Ventilation

The slots and openings in the cabinet are provided for necessary ventilation. To ensure reliable operation of the set, and to protect it from overheating, these slots and openings must never be blocked or covered.

- Never cover the slots and openings with a cloth or other materials.
- Never block the slots and openings by placing the set on a bed, sofa, rug, or other similar surface.
- Never place the set in a confined space, such as a bookcase, or built-in cabinet, unless proper ventilation is provided.
- Do not place the set near or over a radiator or heat register, or where it is exposed to direct sunlight.

Lightning

For added protection for this set during a lightning storm, or when it is left unattended and unused for

long periods of time, unplug it from the wall outlet and disconnect the antenna or cable system. This will prevent damage to the set due to lightning and power-line surges.

Service

Damage Requiring Service

Unplug the set from the wall outlet and refer servicing to qualified service personnel under the following conditions:

- When the power cord or plug is damaged or frayed.
- If liquid has been spilled or objects have fallen into the set.
- If the set has been exposed to rain or water.
- If the set has been subject to excessive shock by being dropped, or the cabinet has been damaged.
- If the set does not operate normally when following the operating instructions. Adjust only those controls that are specified in the operating instructions. Improper adjustment of other controls may result in damage and will often require extensive work by a qualified technician to restore the set to normal operation.
- When the set exhibits a distinct change in performance – this indicates a need for service.

Servicing

Do not attempt to service the set yourself as opening or removing covers may expose you to dangerous voltage or other hazards.

Refer all servicing to qualified service personnel.

Replacement parts

When replacement parts are required, be sure the service technician has used replacement parts specified by the manufacturer that have the same characteristics as the original parts.

Unauthorized substitutions may result in fire, electric shock, or other hazards.

Safety Check

Upon completion of any service or repairs to the set, ask the service technician to perform routine safety checks (as specified by the manufacturer) to determine that the set is in safe operating condition.

Read this first

CAUTION

Replace the battery with the specified type only. Otherwise, fire or injury may result.

Do not expose the batteries to excessive heat such as sunshine, fire or the like.

For Customers in the U.S.A. and Canada

RECYCLING LITHIUM-ION BATTERIES

Lithium-Ion batteries are recyclable.

You can help preserve our environment by returning your used rechargeable batteries to the collection and recycling location nearest you.



For more information regarding recycling of rechargeable batteries, call toll free 1-800-822-8837, or visit <http://www.rbc.org/>

Caution: Do not handle damaged or leaking Lithium-Ion batteries.

Battery charger

This power unit is intended to be correctly orientated in a vertical or floor mount position.

For Customers in the U.S.A.

If you have any questions about this product, you may call:

Sony Customer Information Center
1-800-222-SONY (7669)

The number below is for the FCC related matters only.

Regulatory Information

Declaration of Conformity

Trade Name: SONY
Model No.: DSC-T300
Responsible Party: Sony Electronics Inc.
Address: 16530 Via Esprillo,
San Diego, CA 92127 U.S.A.
Telephone No.: 858-942-2230

This device complies with Part 15 of the FCC Rules. Operation is subject to the following two conditions: (1) This device may not cause harmful interference, and (2) this device must accept any interference received, including interference that may cause undesired operation.

CAUTION

You are cautioned that any changes or modifications not expressly approved in this manual could void your authority to operate this equipment.

Note:

This equipment has been tested and found to comply with the limits for a Class B digital device, pursuant to Part 15 of the FCC Rules.

These limits are designed to provide reasonable protection against harmful interference in a residential installation. This equipment generates, uses, and can radiate radio frequency energy and, if not installed and used in accordance with the instructions, may cause harmful interference to radio communications. However, there is no guarantee that interference will not occur in a particular installation. If this equipment does cause harmful interference to radio or television reception, which can be determined by turning the equipment off and on, the user is encouraged to try to correct the interference by one or more of the following measures:

- Reorient or relocate the receiving antenna.
- Increase the separation between the equipment and receiver.
- Connect the equipment into an outlet on a circuit different from that to which the receiver is connected.
- Consult the dealer or an experienced radio/TV technician for help.

The supplied interface cable must be used with the equipment in order to comply with the limits for a digital device pursuant to Subpart B of Part 15 of FCC Rules.

For the State of California, USA only

Perchlorate Material - special handling may apply, See

www.dtsc.ca.gov/hazardouswaste/perchlorate

Perchlorate Material: Lithium battery contains perchlorate.

For Customers in Europe

This product has been tested and found compliant with the limits set out in the EMC Directive for using connection cables shorter than 3 meters (9.8 feet).

Attention

The electromagnetic fields at the specific frequencies may influence the picture and sound of this unit.

Notice

If static electricity or electromagnetism causes data transfer to discontinue midway (fail), restart the application or disconnect and connect the communication cable (USB, etc.) again.

Disposal of Old Electrical & Electronic Equipment (Applicable in the European Union and other European countries with separate collection systems)



This symbol on the product or on its packaging indicates that this product shall not be treated as household waste. Instead it shall be handed over to the applicable collection point for the recycling of electrical and electronic equipment. By ensuring this product is disposed of correctly, you will help prevent potential negative consequences for the environment and human health, which could otherwise be caused by inappropriate waste handling of this product. The recycling of materials will help to conserve natural resources. For more detailed information about recycling of this product, please contact your local Civic Office, your household waste disposal service or the shop where you purchased the product.

Disposal of waste batteries (applicable in the European Union and other European countries with separate collection systems)



This symbol on the battery or on the packaging indicates that the battery provided with this product shall not be treated as household waste.

By ensuring these batteries are disposed of correctly, you will help prevent potentially negative consequences for the environment and human health which could otherwise be caused by inappropriate waste handling of the battery. The recycling of the materials will help to conserve natural resources.

In case of products that for safety, performance or data integrity reasons require a permanent connection with an incorporated battery, this battery should be replaced by qualified service staff only.

To ensure that the battery will be treated properly, hand over the product at end-of-life to the applicable collection point for the recycling of electrical and electronic equipment.

For all other batteries, please view the section on how to remove the battery from the product safely. Hand the battery over to the applicable collection point for the recycling of waste batteries.



For more detailed information about recycling of this product or battery, please contact your local Civic Office, your household waste disposal service or the shop where you purchased the product.

Notice for the customers in the countries applying EU Directives

The manufacturer of this product is Sony Corporation, 1-7-1 Konan Minato-ku Tokyo, 108-0075 Japan. The Authorized Representative for EMC and product safety is Sony Deutschland GmbH, Hedelfinger Strasse 61, 70327 Stuttgart, Germany. For any service or guarantee matters please refer to the addresses given in separate service or guarantee documents.

Notice for customers in the United Kingdom

A moulded plug complying with BS 1363 is fitted to this equipment for your safety and convenience.

Should the fuse in the plug supplied need to be replaced, a fuse of the same rating as the supplied one and approved by ASTA or BSI to BS 1362, (i.e., marked with an  or  mark) must be used.

If the plug supplied with this equipment has a detachable fuse cover, be sure to attach the fuse cover after you change the fuse. Never use the plug without the fuse cover. If you should lose the fuse cover, please contact your nearest Sony service station.

Table of contents

IMPORTANT SAFEGUARDS	2
Read this first	4
Notes on using the camera	8
Getting started	9
Checking the accessories supplied	9
1 Preparing the battery pack	10
2 Inserting the battery pack/a "Memory Stick Duo" (not supplied)	11
3 Turning the camera on/setting the clock	13
Shooting images	15
Image size/Self-timer/Shooting mode/Flash/Macro/Display	16
Shooting in Smile Shutter mode	19
Viewing/deleting images	20
Learning the various functions – HOME/Menu	23
Using the HOME screen	23
HOME items	24
Using the menu items	25
Menu items	26
Enjoying your computer	28
Supported Operating Systems for USB connection and application software "Picture Motion Browser" (supplied)	28
Viewing "Cyber-shot Handbook"	29
Indicators on the screen	30
Battery life and memory capacity	33
Battery life and number of images you can record/view	33
Number of still images and recordable time of movies	34
Troubleshooting	35
Battery pack and power	35
Shooting still images/movies	36
Viewing images	36
Precautions	37
Specifications	38

Notes on using the camera

Internal memory and “Memory Stick Duo” back up

Do not turn off the camera, remove the battery pack, or remove the “Memory Stick Duo” while the access lamp is lit. Otherwise, the internal memory data or “Memory Stick Duo” may be damaged. Be sure to make a backup copy to protect your data.

Notes on recording/playback

- Before you start recording, make a trial recording to make sure that the camera is working correctly.
- The camera is neither dust-proof, nor splash-proof, nor water-proof. Read “Precautions” (page 37) before operating the camera.
- Avoid exposing the camera to water. If water enters inside the camera, a malfunction may occur. In some cases, the camera cannot be repaired.
- Do not aim the camera at the sun or other bright light. It may cause the malfunction of the camera.
- Do not use the camera near a location that generates strong radio waves or emits radiation. Otherwise, the camera may not properly record or play back images.
- Using the camera in sandy or dusty locations may cause malfunctions.
- If moisture condensation occurs, remove it before using the camera (page 37).
- Do not shake or strike the camera. It may cause a malfunction and you may not be able to record images. Furthermore, the recording media may become unusable or image data may be damaged.
- Clean the flash surface before use. The heat of flash emission may cause dirt on the flash surface to become discolored or to stick to the flash surface, resulting in insufficient light emission.

Notes on the LCD screen

- The LCD screen is manufactured using extremely high-precision technology so over 99.99% of the pixels are operational for effective use. However, some tiny black and/or bright dots (white, red, blue or green) may appear on the LCD screen. These dots are a normal result of the manufacturing process, and do not affect the recording.
- If water droplets or other liquids splash on the LCD screen and make it wet, immediately wipe off the screen with a soft cloth. Leaving liquids on the LCD screen surface can harm the quality and cause a malfunction.

On image data compatibility

- The camera conforms with DCF (Design rule for Camera File system) universal standard established by JEITA (Japan Electronics and Information Technology Industries Association).
- Sony does not guarantee that the camera will play back images recorded or edited with other equipment, or that other equipment will play back images recorded with the camera.

Warning on copyright

Television programs, films, videotapes, and other materials may be copyrighted. Unauthorized recording of such materials may be contrary to the provisions of the copyright laws.

No compensation for damaged content or recording failure

Sony cannot compensate for failure to record or loss or damage of recorded content due to a malfunction of the camera or recording media, etc.

Getting started

Checking the accessories supplied

- Battery charger BC-CSD (1)

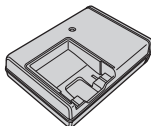

- Power cord (mains lead) (1)
(not supplied in the USA and Canada)



- Rechargeable battery pack NP-BD1 (1)/
Battery case (1)

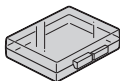
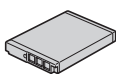

- Paint pen (1)

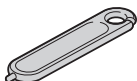

- USB, A/V cable for multi-use terminal (1)

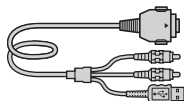

- Wrist strap (1)



- CD-ROM (1)
 - Cyber-shot application software
 - “Cyber-shot Handbook”
 - “Cyber-shot Step-up Guide”
- Instruction Manual (this manual) (1)

About the wrist strap

Attach the strap and place your hand through the loop to prevent the camera from damage by being dropped.

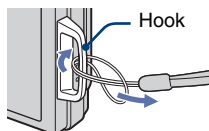

About the paint pen

- You can paint or put stamps on still images with the paint pen.
- Attach the paint pen to the wrist strap (shown right).
- Do not carry the camera by holding the paint pen. The camera may fall off.

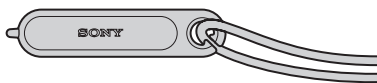

1 Preparing the battery pack

For customers in the USA and Canada

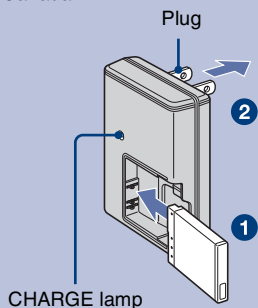

For customers in countries/regions other than the USA and Canada

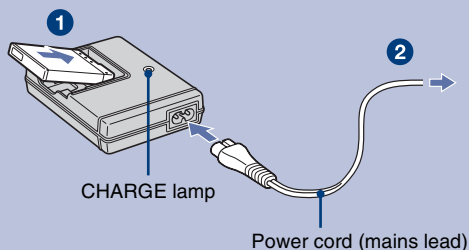

1 Insert the battery pack into the battery charger.

2 Connect the battery charger to the wall outlet (wall socket).

The CHARGE lamp lights up, and charging starts.

When the CHARGE lamp turns off, charging is finished (Normal charge).

If you continue charging the battery pack for about one more hour (until it is fully charged), the charge will last slightly longer.

Charging time

Full charge time	Normal charge time
Approx. 220 min.	Approx. 160 min.

- The table above shows the time required to charge a fully depleted battery pack at a temperature of 25°C (77°F). Charging may take longer depending on conditions of use and circumstances.
- See page 33 for the number of images that can be recorded.
- Connect the battery charger to the nearest wall outlet (wall socket).
- Even if the CHARGE lamp is not lit, the battery charger is not disconnected from the AC power source (mains) as long as it is connected to the wall outlet (wall socket). If some trouble occurs while using the battery charger, immediately shut off the power by disconnecting the plug from the wall outlet (wall socket).
- When charging is finished, disconnect the power cord (mains lead) from the wall outlet (wall socket), and remove the battery pack from the battery charger.
- Designed for use with compatible Sony batteries.

2 Inserting the battery pack/a “Memory Stick Duo” (not supplied)

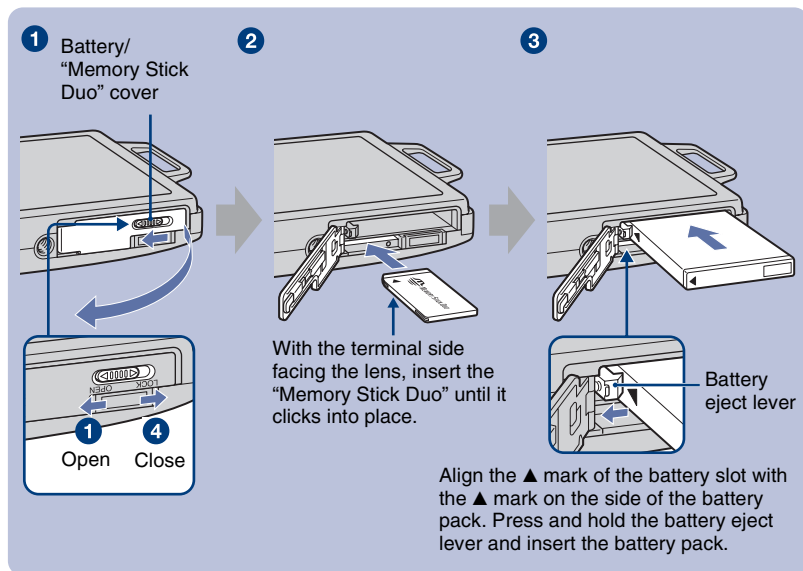

1 Open the battery/“Memory Stick Duo” cover.

2 Insert the “Memory Stick Duo” (not supplied).

3 Insert the battery pack.





4 Close the battery/“Memory Stick Duo” cover.

When there is no “Memory Stick Duo” inserted

The camera records/plays back images using the internal memory (approx. 15 MB).

To check the remaining battery charge

Press POWER button to turn on and check the remaining battery charge on the LCD screen.

Remaining charge indicator					
Status	Sufficient power remaining	Battery almost fully charged	Battery half full	Battery low, recording/playback will stop soon.	Change the battery with fully charged one, or charge the battery. (The warning indicator flashes.)

- If the NP-FD1 battery pack (not supplied) is used, the minute display ( 60 Min) is also shown after the remaining charge indicator.
- It takes about one minute until the correct remaining charge indicator appears.
- The remaining charge indicator may not be correct under certain circumstances.
- The Clock Set screen appears when you turn on the camera for the first time (page 13).

To remove the battery pack/“Memory Stick Duo”

Open the battery/“Memory Stick Duo” cover.

“Memory Stick Duo”

Make sure that **the access lamp** is not lit, then push the “Memory Stick Duo” in once.

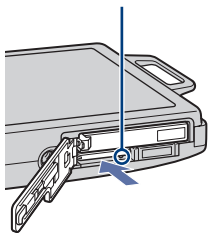

Battery pack

Slide **the battery eject lever**. Be sure not to drop the battery pack.

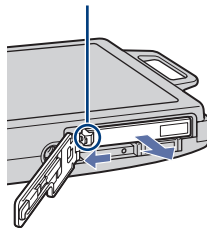

- Never remove the battery pack/“Memory Stick Duo” when the access lamp is lit. This may cause damage to data in the “Memory Stick Duo”/internal memory.
- Use the NP-BD1 battery pack (supplied) only with this camera.

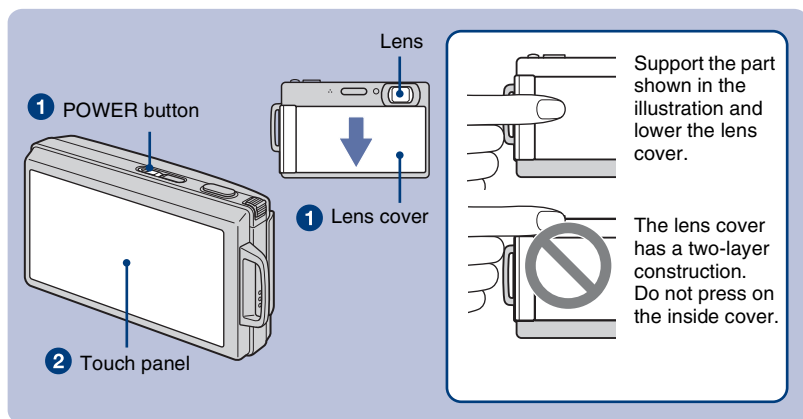

3 Turning the camera on/setting the clock



1 Press the POWER button or slide the lens cover downward.

- Be careful not to apply force to the lens cover when lowering it.



2 Set the clock by touching the button on the touch panel.

- 1 Touch the desired date display format, then touch .
- 2 Touch each item, then set its numeric value by touching /.
- 3 Touch [OK].

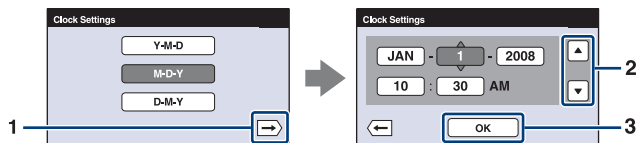
- The camera does not have a feature for superimposing dates on images. By using “Picture Motion Browser” in the CD-ROM (supplied), you can print or save images with the date.
- Midnight is indicated as 12:00 AM, and noon as 12:00 PM.



To set the date and time again

Touch [HOME], then touch  (Settings) → [ Clock Settings] (pages 23, 24).

Notes on when the power is turned on

- Once the battery is inserted in the camera, it may take time before operation becomes possible.
- If the camera is running on battery power and you do not operate the camera for about three minutes, the camera turns off automatically to prevent wearing down the battery pack (Auto power-off function).



On the touch panel buttons

Perform settings on this camera by lightly touching the buttons on the screen with your finger.

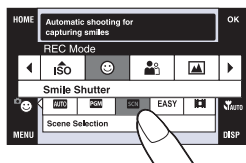
- When the item you want to set is not on the screen, touch ▲/▼/◀/▶ to change the page.
- You can return to the previous screen by touching [BACK] or [X].
- Touching [OK] advances to the next screen.
- If you touch the top right of the screen during shooting, the buttons and icons will momentarily disappear. The buttons and icons will reappear when you take your finger off the screen.



Perform calibration if response to your touch is poor.

- ① Touch [HOME] and under  (Settings) select [ Main Settings] → [Calibration].
- ② Use the paint pen to touch the center of the x mark displayed on the screen.

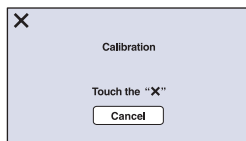

Shooting images

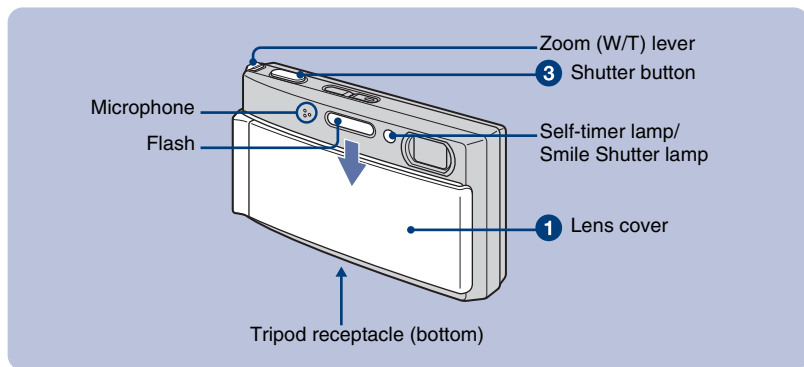

1 Open the lens cover.

2 Hold the camera, with your elbows pressed against your body to steady it.

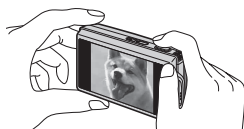

Position the subject in the center of the focus frame.

- You can select the point to bring into focus by touching the screen. is displayed on the top right of the screen if a face is detected at the touched position or is displayed if an object other than a person's face is detected.

3 Shoot with the shutter button.

When shooting still images:

1 Press and hold the shutter button halfway down to focus.

The ● (AE/AF lock) indicator (green) flashes, a beep sounds, the indicator stops flashing and remains lit.

2 Press the shutter button fully down.



AE/AF lock indicator

When shooting movies:

Touch the shooting mode setting button, then touch (Movie Mode) (pages 16, 17).

- The shortest shooting distance is approximately 8 cm (3 1/4 inches) (W)/80 cm (31 1/2 inches) (T) (from the lens).

Using the zoom:

Slide the zoom (W/T) lever to the T side to zoom and slide to the W side to return.

Image size/Self-timer/Shooting mode/Flash/Macro/Display

This section describes the basic buttons that appear on the touch panel. Touch the button and when finished making settings touch [OK].

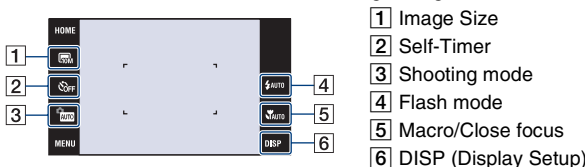



Changing the image size

Touch the image size setting button on the screen.

Still image

: For prints up to A3+(13×19")

: For prints up to A4(8×10")

: For prints up to 10×15 cm (4×6") or 13×18 cm (5×7")

: Shoot at small image size for e-mail attachments

: Shoot in 3:2 aspect ratio

*: For viewing on HDTVs and printing up to A4(8×10")

*: For viewing on HDTVs

* Images shot with a 16:9 aspect ratio fill the entire screen.

Movie

 (Fine): Shoot high quality movie for display on TV

 (Standard): Shoot standard quality movie for display on TV

: Shoot at small image size for e-mail attachments

Using the self-timer

Touch the self-timer setting button on the screen.

: Not using the self-timer







: Setting the 10-second delay self-timer

: Setting the 2-second delay self-timer

When you press the shutter button, the self-timer lamp flashes and a beep sounds until the shutter operates.











Changing the shooting mode

Touch the shooting mode setting button on the screen.

	Auto Adjustment	Allows you to shoot still images with the setting adjusted automatically.
	Program Auto	Allows you to shoot with the exposure adjusted automatically (both the shutter speed and the aperture value). You can adjust other settings using the menu. 
	Scene Selection	Allows you to shoot with preset settings according to the scene.
	Easy Shooting	Allows easy shooting with easy-to-see indicators.
	Movie Mode	Allows you to record movies with audio.

Scene Selection

Touch , then select the desired mode.

	High Sensitivity	Shoots images without a flash even in low lighting.
	Smile Shutter	When the camera detects a smile, the shutter is released automatically (page 19).
	Soft Snap	Shoots images with a softer atmosphere for portraits of people, flowers, etc.
	Landscape	Shoots with the focus on a distant subject.
	Twilight Portrait	Shoots sharp images of people in a dark place without losing the nighttime atmosphere.
	Twilight	Shoots night scenes without losing the nighttime atmosphere.
	Beach	Shoots seaside or lakeside scenes with the blueness of the water captured more vividly.
	Snow	Shoots snow scenes in white more clearly.
	Fireworks	Shoots fireworks in all their splendor.
	Underwater	Shoots underwater in natural colors when the water-proof case is attached.
	Hi-Speed Shutter	Shoots moving subjects in bright places.

Flash (Selecting a flash mode for still images)

Touch the flash mode setting button on the screen.

 **AUTO**: Flash Auto

Flashes when there is insufficient light or backlight (default setting)

 **F**: Flash forced on

 **SL**: Slow synchro (Flash forced on)

The shutter speed is slow in a dark place to clearly shoot the background that is out of flash light.

 **OFF**: Flash forced off

Macro/Close focus enabled (Shooting close-up)

Touch the Macro/Close focus mode setting button on the screen.

 **AUTO**: Auto

The camera adjusts the focus automatically from distant subjects to close-up. Normally, put the camera in this mode.

 **M**: Macro On

The camera adjusts the focus with priority on close-up subjects. Set Macro On when shooting close subjects.

 **CF**: Close focus enabled

Locked to the W side: Approx. 1 to 20 cm (13/32 to 7 7/8 inches)

Changing the screen display

Touch [DISP] on the screen to change to the display selection screen.

Display Setup: This sets whether or not to display the buttons and icons on the screen.

Select from [Normal], [Simple] or [Image Only].

Display Histogram: This sets whether or not to display the histogram on the screen.

LCD Brightness: This sets the backlight brightness.

Shooting in Smile Shutter mode

When the camera detects a smile, the shutter is released automatically.

1 Touch **SCN** (Scene Selection) for the shooting mode and set to **☺** (Smile Shutter) mode (page 17).

2 Press the shutter button all the way down to set Smile Detection mode.

The Smile Shutter enters standby.

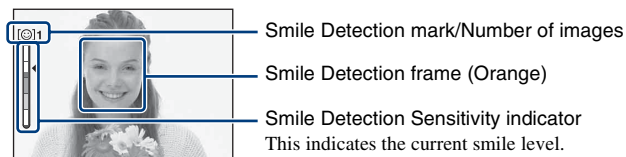

Each time the smile level reaches the set Smile Detection Sensitivity (indicated by ◀), the camera automatically operates the shutter and records up to six images. After recording the image, the Smile Shutter lamp lights.



3 Press the shutter button all the way down again to exit the Smile Shutter mode.

- Shooting using the Smile Shutter ends automatically when either the “Memory Stick Duo” or internal memory becomes full or when six images have been recorded.
- You can select the subject that has priority for smile detection with [Smile Detection] (page 26).
- If a smile is not detected, set the [Smile Detection Sensitivity] (page 26).
- You can have the camera shoot the image automatically when any person displayed in the smile detection frame (Orange) smiles after pressing the shutter button all the way down.
- The image may not be in focus if the distance between the camera and the subject is changed after pressing the shutter button all the way down. The suitable exposure may not be obtained if the surrounding brightness changes.
- Faces may not be detected correctly when:
 - It is too dark or too bright.
 - Faces are partially hidden by sunglasses, masks, hats, etc.
 - The subjects are not facing the camera.
- Smiles may not be detected correctly depending on the conditions.
- You cannot use the Digital Zoom function.
- You cannot change the zoom ratio when the Smile Shutter is in standby.

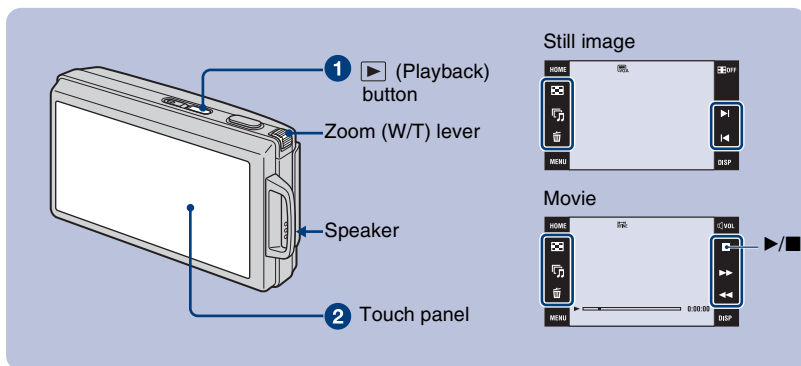
Viewing/deleting images







1 Press (Playback) button.



If you press  (Playback) when the camera is powered off, the camera is turned on automatically and set to playback mode. To switch to the shooting mode, press  (Playback) again.

2 Touch (previous) / (next) on the screen to select an image.

Movie:

Touch  to playback a movie.



Fast forward/Rewind:  /  (Touch  to return to normal playback.)

Volume control: Touch /vol. during movie playback, then adjust the volume with /vol. or /vol.

Touch [Exit] to turn off the volume control screen.

Stop: Touch .

- You may not be able to play back some images shot using an earlier Sony model.

Touch [HOME], then select  Folder View] from  (View Images) to play back these images.





To delete images



1 Display the image you want to delete, then touch  (Delete).

2 Touch [OK].

To view an enlarged image (playback zoom)

Touch a still image while it is displayed to enlarge the corresponding area.

 /  /  / : Adjusts the position.

 / : Changes the zoom scale.



: Turns  /  /  /  on/off.

[BACK]: Cancels playback zoom.

- You can also enlarge the image by sliding the zoom (W/T) lever to the T side. Slide the lever to the W side to return.

To view an index screen

Touch  (Index) to display the index screen.

Touch / to display the previous/next page.

To return to the single image screen, touch the thumbnail image.

- Under default settings, the display is shown in Date View (when using a “Memory Stick Duo”) or Folder View (when using the internal memory). You can change the View Mode using  (View Images) on the HOME screen (page 24).
- If you touch [DISP] in index mode, you can set the number of images displayed in the index screen to 12 or 20 images.

To delete images in index mode



1 Touch  (Delete) while the index screen is displayed.

2 Touch the thumbnail images you want to delete.

✓ mark is checked in the check box of the image.

To cancel the deletion, touch the image again to deselect the mark.

3 Touch , and then touch [OK].

- To delete all the images in the selected date range or folder, select  (All Images in Date Range) or  (All In This Folder) from  (Delete) in the menu screen, then touch [OK].



To play back a series of images (Slideshow)

1 Touch  (Slideshow).

2 Touch [Start].

The music will change together with the [Effects]. You can also transfer and change the music to your desired music.

To transfer and change the music, take the following steps.

- ① Touch [HOME]. Then select  Music Tool] → [Download Music] in  (Slideshow) (pages 23, 24).
- ② Install the software included in the CD-ROM (supplied) to your computer.
- ③ Connect the camera and a computer with USB cable.
- ④ Start up “Music Transfer” installed to your computer and change the music.
For details on changing the music, refer to Help in “Music Transfer”.

To view images on TV

Connect the camera to the TV with the cable for multi-use terminal (supplied).

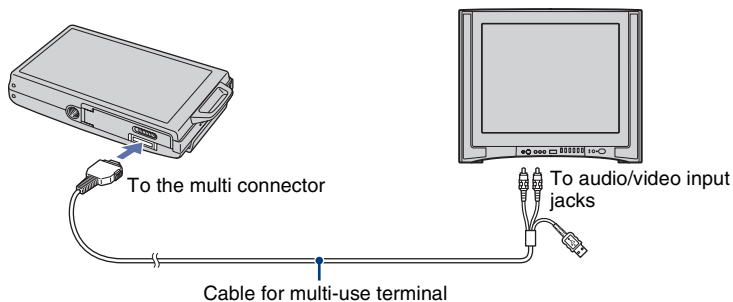

To view on HD (High Definition) TV, an HD Output Adaptor Cable (not supplied) is needed.

- If you set the image size to [16:9], you can record images in the size that fills the entire screen of the HD TV.
- You cannot view movies output in [HD(1080i)] signal format. Set [COMPONENT] to [SD] when shooting movies.

Learning the various functions – HOME/Menu

Using the HOME screen

The HOME screen is the gateway screen for all the functions of the camera, and can be called up regardless of the mode setting (shooting/viewing).

- 1 Touch [HOME] to display the HOME screen.

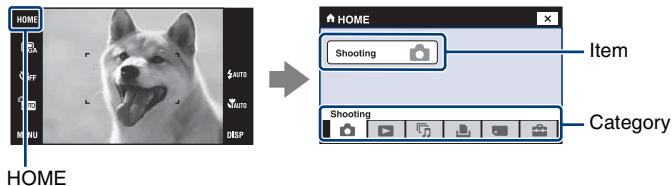

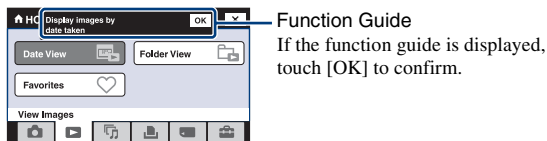

- 2 Touch the category you want to set.
- 3 Touch the item in the category you want to set.



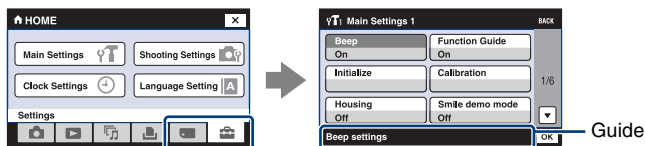





When you select the (Manage Memory) or (Settings) category



- 1 Touch the item you want to change the settings.
 - If you select  (Manage Memory), touch  Memory Tool].
- 2 Touch ▲/▼ to display the other setting items.
 - This operation only applies when  (Settings) has been selected.
- 3 Touch the setting item that you want to change, then touch [OK].
- 4 Touch the desired setting value.
 - Touch [X] or [BACK] to return to the previous screen.

HOME items

Touching [HOME] displays the following items. Only the available items are displayed on the screen. Details on each item are displayed in the guide at the bottom of the screen.

Categories	Items
 Shooting	Shooting
 View Images	Date View Folder View Favorites
 Slideshow	Slideshow Music Tool Download Music Format Music
 Print	Print
 Manage Memory	Memory Tool Memory Stick Tool Format Create REC.Folder Change REC.Folder Copy Internal Memory Tool Format
 Settings	Main Settings Main Settings 1 Beep Function Guide Initialize Calibration Housing Smile demo mode Main Settings 2 USB Connect COMPONENT Video Out TV TYPE
	Shooting Settings Shooting Settings 1 AF Illuminator Grid Line AF Mode Digital Zoom Shooting Settings 2 Auto Orientation Auto Review
	Clock Settings
	Language Setting

Using the menu items

1 Touch [MENU] to display the menu.

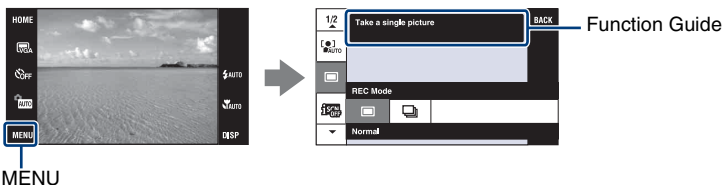

- Different items will become visible depending on the selected mode.

2 Touch a desired menu item.

- If the desired item is hidden, keep touching ▲/▼ until the item appears on the screen.

3 Touch a desired setting item.

4 Touch [OK] to turn off the menu.















Menu items

The available menu items vary depending on the mode setting (shooting/viewing) and the shooting mode. Only the available items are displayed on the screen.

Shooting menu

Image Size	Selects the still image size in Easy Shooting mode.
Flash	Selects the flash setting in Easy Shooting mode.
Face Detection	Selects the priority subject for adjusting the focus when using face detection.
Smile Detection	Selects the priority subject for the Smile Shutter function.
Smile Detection Sensitivity	Sets the level of sensitivity to detect smile.
REC Mode	Selects the continuous shooting method.
Scene Recognition	Automatically detects the shooting conditions and then takes the shot.
EV	Adjusts Exposure.
Metering Mode	Selects the metering mode.
Focus	Changes the focus method.
White Balance	Adjusts the color tones.
Underwater White Balance	Adjusts the colors when shooting underwater.
Flash Level	Adjusts the amount of flash light.
Red Eye Reduction	Sets to reduce the red-eye phenomenon.
DRO	Optimizes the brightness and contrast.
Color Mode	Changes the vividness of the image or adds special effects.
SteadyShot	Selects the anti-blur mode.
Shooting Settings	Selects the shooting settings.

Viewing menu

 (Date List)	Selects the playback date.
 (Filter by Faces)	Plays back images filtered to meet certain conditions.
 (Add / Remove Favorites)	Registers images to Favorites or removes images from Favorites.
 (View Mode)	Switches the View Mode.
 (Wide Zoom Display)	Displays still images in 16:9.
 (Slideshow)	Sets and executes a slideshow (consecutive playback).
 (Retouch)	Retouches still images.
 (Paint)	Paints on a still image and saves as a new image.
 (Multi-Purpose Resize)	Changes the image size according to usage.
 (Delete)	Deletes images.
 (Protect)	Prevents accidental erasure.
DPOF	Adds a Print order mark on image that you want to print out.
 (Print)	Prints images using a PictBridge compliant printer.
 (Rotate)	Rotates a still image.
 (Select Folder)	Selects the folder for viewing images.
 (Volume Settings)	Adjusts the volume.

Enjoying your computer

You can view images shot with the camera on a computer. By using the software in the CD-ROM (supplied), you can enjoy still images and movies from the camera more than ever. For details, refer to “Cyber-shot Handbook” in the CD-ROM (supplied).

Supported Operating Systems for USB connection and application software “Picture Motion Browser” (supplied)

	For Windows users	For Macintosh users
USB connection	Windows 2000 Professional SP4, Windows XP* SP2/Windows Vista*	Mac OS 9.1/9.2/ Mac OS X (v10.1 to v10.5)
Application software “Picture Motion Browser”	Windows 2000 Professional SP4, Windows XP* SP2/Windows Vista*	not compatible

* 64-bit editions and Starter (Edition) are not supported.

- Your computer must be pre-installed with an OS listed above. OS upgrades are not supported.
- If your OS does not support USB connections, copy images by inserting the “Memory Stick Duo” into the Memory Stick slot on your computer, or use a commercially available Memory Stick Reader/Writer.
- For further details on the operating environment of “Picture Motion Browser” Cyber-shot application software, refer to “Cyber-shot Handbook.”



Viewing “Cyber-shot Handbook”

“Cyber-shot Handbook” in the CD-ROM (supplied) explains how to use the camera in detail. Adobe Reader is required to view it.

For Windows users

- 1 Turn on your computer, and insert the CD-ROM (supplied) into the CD-ROM drive. The screen below appears.



When you click the [Cyber-shot Handbook] button, the screen for copying “Cyber-shot Handbook” appears.

- 2 Follow the on-screen instructions to copy.
 - When you install “Cyber-shot Handbook”, the “Cyber-shot Step-up Guide” will be installed automatically.
- 3 After the installation is complete, double-click the shortcut created on the desktop.

For Macintosh users

- 1 Turn on your computer, and insert the CD-ROM (supplied) into the CD-ROM drive.
- 2 Select the [Handbook] folder and copy “Handbook.pdf” stored in the [GB] folder to your computer.
- 3 After copying is complete, double-click “Handbook.pdf”.

Indicators on the screen

Touch [DISP] on the screen to change to the display selection screen (page 18).

When shooting still images

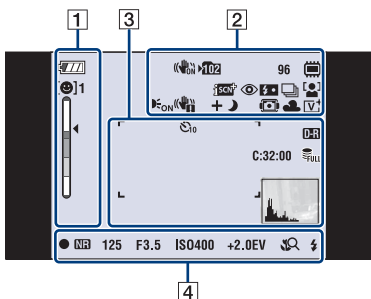

- The indicators are limited in **EASY** (Easy Shooting) mode.

When shooting movies

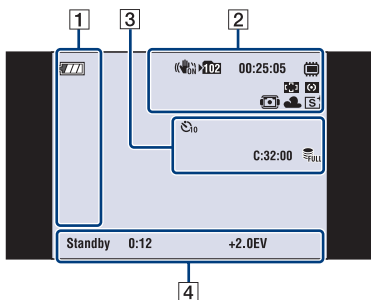

When playing back

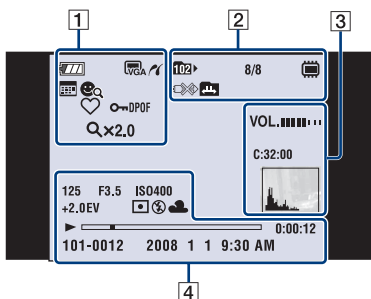

















1





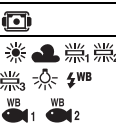



Display	Indication
	Battery remaining
	Low battery warning
	Image size
	PictBridge connecting
	Smile Detection Sensitivity indicator/Number of images
	Zoom scaling
	View Mode
	Filter by Faces
	Favorites
	Protect
	Print order (DPOF) mark
	Playback zoom

2











Display	Indication
	SteadyShot
	Recording folder
	Playback folder



Display	Indication
96	Number of recordable images
8/8	Image number/Number of images recorded in selected folder
00:25:05	Recordable time (h:m:s)
	Recording/Playback Media ("Memory Stick Duo", internal memory)
	PictBridge connecting
	Changing folder
	Scene Recognition
	Red-eye reduction
	Flash level
	Flash charging
	Recording mode
	Face Detection/Smile Detection
	Metering Mode
	Focus
	AF illuminator
	Vibration warning
	Touch AF indicator
	Housing
	White balance
	Color mode

3

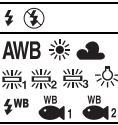
Display	Indication
	AF range finder frame
	Self-timer
	DRO
	Database full
	Volume
	Self-diagnosis display
	Histogram <ul style="list-style-type: none"> •  appears when histogram display is disabled.

4

Display	Indication
	AE/AF lock
	NR slow shutter
	Shutter speed
	Aperture value
	ISO number
	Exposure Value
	Metering mode
	Flash
	White balance
	Macro/Close focus <ul style="list-style-type: none"> • Displayed when [Display Setup] is set to [Image Only].
	Flash mode <ul style="list-style-type: none"> • Displayed when [Display Setup] is set to [Image Only].

Display	Indication
Standby REC	Standby a movie/Recording a movie
0:12	Recording time (m:s)
	Playback
	Playback bar
0:00:12	Counter
101-0012	Folder-file number
2008 1 1 9:30 AM	Recorded date/time of the playback image

Battery life and memory capacity

Battery life and number of images you can record/view

The numbers shown in the following tables assume a fully charged battery pack (supplied) is used at an ambient temperature of 25°C (77°F). The numbers shown for images you can record/view are approximations and allow for changing of the “Memory Stick Duo” as necessary. Note that the actual numbers may be less than those indicated in the table depending on the conditions of use.

When shooting still images

Battery life (min.)	No. of Images
Approx. 130	Approx. 260

- Shooting in the following situations:
 - [REC Mode] is set to [Normal].
 - [AF Mode] is set to [Single].
 - [SteadyShot] is set to [Shooting].
 - Shooting once every 30 seconds.
 - The zoom is switched alternately between the W and T ends.
 - The flash strobes once every two times.
 - The power turns on and off once every ten times.
- The measurement method is based on the CIPA standard.
(CIPA: Camera & Imaging Products Association)
- The battery life and the number of images do not change, regardless of image size.

When viewing still images

Battery life (min.)	No. of Images
Approx. 220	Approx. 4400

- Viewing single images in order at about three second intervals

Notes on the battery

- Battery capacity decreases over time and through repeated use.
- The battery life and the number of images you can record/view are decreased under the following conditions:
 - The surrounding temperature is low.
 - The flash is used frequently.
 - The camera has been turned on and off many times.
 - The zoom is used frequently.
 - The brightness of LCD Backlight is set to up.
 - [AF Mode] is set to [Monitor].
 - [SteadyShot] is set to [Continuous].
 - The battery power is low.
 - The Face Detect function is activated.

Number of still images and recordable time of movies

The number of still images and the length of time for movies may vary depending on the shooting conditions.

- Even if the capacity displayed on the media is the same as the one in the table below, the number of still images and the length of time for movies may be different.

The approximate recordable number of still images

(Units: Images)

Capacity Size	Internal memory	"Memory Stick Duo" formatted with this camera						
	Approx. 15 MB	128 MB	256 MB	512 MB	1 GB	2 GB	4 GB	8 GB
10M	3	32	58	120	246	496	982	1973
5M	6	51	92	190	390	786	1556	3127
3M	10	81	148	305	625	1261	2497	5016
VGA	96	782	1420	2932	6000	12102	23956	48138
3:2(8M)	3	32	58	121	248	500	990	1990
16:9(7M)	4	34	61	127	261	526	1042	2093
16:9(2M)	16	132	236	489	1001	2018	3995	8025

- The numbers of images listed assume [REC Mode] is set to [Normal].
- When the number of remaining shootable images is greater than 9,999, the ">9999" indicator appears.
- When an image was recorded using an earlier Sony model and is played back on the camera, the image may not appear in the actual image size.

The approximate recordable time of movies

The table below shows the approximate maximum recording times. These are the total times for all movie files. Continuous shooting is possible for approximately 10 minutes.

(Units: hour : minute : second)

Capacity Size	Internal memory	"Memory Stick Duo" formatted with this camera						
	Approx. 15 MB	128 MB	256 MB	512 MB	1 GB	2 GB	4 GB	8 GB
640(Fine)	–	–	0:02:50	0:06:00	0:12:30	0:25:10	0:49:50	1:40:10
640(Standard)	0:00:40	0:05:50	0:10:30	0:22:00	0:45:00	1:30:50	2:59:40	6:01:00
320	0:02:50	0:23:20	0:42:30	1:28:00	3:00:00	6:03:10	11:59:00	24:04:10

- Movies with the size set to [640(Fine)] can only be recorded on a "Memory Stick PRO Duo".
- This camera does not support HD recordings or playbacks for movies.

Troubleshooting

If you experience trouble with the camera, try the following solutions.

❶ Check the items below, and refer to “Cyber-shot Handbook” (PDF).

If a code such as “C/E:□□:□□” appears on the screen, refer to “Cyber-shot Handbook.”

❷ Remove the battery pack, wait for about one minute, re-insert the battery pack, then turn on the power.

❸ Initialize the settings (page 24).

❹ Consult your Sony dealer or local authorized Sony service facility.

Be aware that by sending the camera for repair, you give consent that the contents of the internal memory and Music files may be checked.

Battery pack and power

Cannot insert the battery pack.

- Insert the battery pack correctly by pressing and holding the battery eject lever open (page 11).

Cannot turn on the camera.

- After inserting the battery pack into the camera, it may take a few moments for the camera to power up.
- Insert the battery pack correctly (page 11).
- The battery pack is discharged. Insert charged battery pack (page 10).
- The battery pack is dead. Replace it with a new one.
- Use a recommended battery pack.

The power turns off suddenly.

- If you do not operate the camera for about three minutes while the power is on, the camera turns off automatically to prevent wearing down the battery pack. Turn on the camera again (page 13).
- The battery pack is dead. Replace it with a new one.

The remaining charge indicator is incorrect.



- This phenomenon occurs when you use the camera in an extremely hot or cold location.
- A discrepancy arose between the remaining charge indicator and the actual remaining battery charge. Fully discharge the battery pack once, then charge it to correct the indication.
- The battery pack is discharged. Insert the charged battery pack (page 10).
- The battery pack is dead. Replace it with a new one.

The battery cannot be charged while inside the camera.

- You cannot charge the battery pack using the AC Adaptor (not supplied). Use the battery charger (supplied) to charge the battery.

Shooting still images/movies

Cannot record images.

- Check the free capacity of the internal memory or “Memory Stick Duo” (page 34). If it is full, do one of the following:
 - Delete unnecessary images (page 20).
 - Change the “Memory Stick Duo”.
- You cannot record images while charging the flash.
- When shooting a still image, set the shooting mode other than .
- Set the shooting mode to  when shooting movies.
- The image size is set to [640(Fine)] when recording movies. Do one of the following:
 - Set the image size to other than [640(Fine)].
 - Insert a “Memory Stick PRO Duo.”

Vertical streaks appear when you are shooting a very bright subject.

- The smear phenomenon is occurring and white, black, red, purple or other streaks appear on the image. This phenomenon is not a malfunction.

Viewing images

Cannot play back images.

- Press  (Playback) button (page 20).
- The folder/file name has been changed on your computer.
- Sony does not guarantee playback of image files on the camera if the files have been processed using a computer or recorded with another camera.
- The camera is in USB mode. Delete the USB connection.
- Playback is impossible if the Smile Shutter is in standby mode. Exit standby mode by pressing the shutter button all the way down.
- You may not be able to play back some images stored on the “Memory Stick Duo” shot using an earlier Sony model. Play such images in Folder View (page 24).
- This is caused by copying images on the PC to the “Memory Stick Duo” without using the “Picture Motion Browser”. Play such images in Folder View (page 24).

Precautions

Do not use/store the camera in the following places

- In an extremely hot, cold or humid place
In places such as in a car parked in the sun, the camera body may become deformed and this may cause a malfunction.
- Under direct sunlight or near a heater
The camera body may become discolored or deformed, and this may cause a malfunction.
- In a location subject to rocking vibration
- Near strong magnetic place
- In sandy or dusty places
Be careful not to let sand or dust get into the camera. This may cause the camera to malfunction, and in some cases this malfunction cannot be repaired.

On carrying

Do not sit down in a chair or other place with the camera in the back pocket of your trousers or skirt, as this may cause malfunction or damage the camera.

On cleaning

Cleaning the LCD screen

Wipe the screen surface with an LCD cleaning kit (not supplied) to remove fingerprints, dust, etc.

Cleaning the lens

Wipe the lens with a soft cloth to remove fingerprints, dust, etc.

Cleaning the camera surface

Clean the camera surface with a soft cloth slightly moistened with water, then wipe the surface with a dry cloth. To prevent damage to the finish or casing:

- Do not expose the camera to chemical products such as thinner, benzene, alcohol, disposable cloths, insect repellent, sunscreen or insecticide.
- Do not touch the camera with any of the above on your hand.
- Do not leave the camera in contact with rubber or vinyl for a long time.

On operating temperatures

Your camera is designed for use under the temperatures between 0°C and 40°C (32°F and 104°F). Shooting in extremely cold or hot places that exceed this range is not recommended.

On moisture condensation

If the camera is brought directly from a cold to a warm location, moisture may condense inside or outside the camera. This moisture condensation may cause a malfunction of the camera.

If moisture condensation occurs

Turn off the camera and wait about an hour for the moisture to evaporate. Note that if you attempt to shoot with moisture remaining inside the lens, you will be unable to record clear images.

On the internal rechargeable backup battery

This camera has an internal rechargeable battery for maintaining the date and time and other settings regardless of whether the power is on or off.

This rechargeable battery is continually charged as long as you are using the camera. However, if you use the camera for only short periods, it discharges gradually, and if you do not use the camera at all for about one month it becomes completely discharged. In this case, be sure to charge this rechargeable battery before using the camera.

However, even if this rechargeable battery is not charged, you can still use the camera, but the date and time will not be indicated.

Charging method of the internal rechargeable backup battery

Insert charged battery pack in the camera, and then leave the camera for 24 hours or more with the power off.

Specifications

Camera

[System]

Image device: 7.7 mm (1/2.3 type) color CCD,

Primary color filter

Total pixel number of camera:

Approx. 10.3 Megapixels

Effective pixel number of camera:

Approx. 10.1 Megapixels

Lens:

Carl Zeiss Vario-Tessar 5× zoom lens

f = 5.8 – 29.0 mm (33 – 165 mm (35 mm film equivalent))

F3.5 (W) – F4.4 (T)

Exposure control: Automatic exposure, Scene

Selection (11 modes)

White balance: Automatic, Daylight, Cloudy,

Fluorescent 1,2,3, Incandescent, Flash

Underwater White Balance: Auto, Underwater

1,2, Flash

File format (DCF compliant):

Still images: Exif Ver. 2.21 JPEG compliant, DPOF compatible

Movies: MPEG1 compliant (Monaural)

Recording media: Internal Memory

(approx. 15 MB), "Memory Stick Duo"

Flash: Flash range (ISO sensitivity

(Recommended exposure Index) set to Auto):

Approx. 0.1 to 3.5 m (4 inches to 11 feet

5 7/8 inches) (W)/approx. 0.8 to 2.7 m (2 feet

7 1/2 inches to 8 feet 10 3/8 inches) (T)

[Input and Output connectors]

Multi connector: Video output

Audio output (Monaural)

USB communication

USB communication: Hi-Speed USB (USB 2.0 compliant)

[LCD screen]

LCD panel:

Wide (16:9), 8.8 cm (3.5 type) TFT drive

Total number of dots: 230 400 (960 × 240) dots

[Power, general]

Power: Rechargeable battery pack NP-BD1, 3.6 V

NP-FD1 (not supplied), 3.6 V

AC-LS5K AC Adaptor (not supplied), 4.2 V

Power consumption (during shooting):

1.0 W

Operating temperature: 0 to 40°C (32 to 104°F)

Storage temperature: –20 to +60°C (–4 to +140°F)

Dimensions: 94.0 × 59.3 × 21.4 mm

(3 3/4 × 2 3/8 × 7/8 inches)

(W/H/D, excluding protrusions)

Mass (including NP-BD1 battery pack, paint pen

and strap etc.):

Approx. 177 g (6.2 oz)

Microphone: Monaural

Speaker: Monaural

Exif Print: Compatible

PRINT Image Matching III: Compatible

PictBridge: Compatible

BC-CSD battery charger

Power requirements: AC 100 V to 240 V,

50/60 Hz, 2.2 W

Output voltage: DC 4.2 V, 0.33 A

Operating temperature: 0 to 40°C (32 to 104°F)

Storage temperature: –20 to +60°C (–4 to +140°F)

Dimensions: Approx. 62 × 24 × 91 mm (2 1/2 ×

3 1/32 × 3 5/8 inches) (W/H/D)

Mass: Approx. 75 g (2.7 oz)

Rechargeable battery pack NP-BD1

Used battery: Lithium-ion battery

Maximum voltage: DC 4.2 V

Nominal voltage: DC 3.6 V

Capacity: 2.4 Wh (680 mAh)

Design and specifications are subject to change without notice.

Trademarks

- **Cyber-shot**, “Cyber-shot” are trademarks of Sony Corporation.
- “Memory Stick,”  “Memory Stick PRO,” **MEMORY STICK PRO**, “Memory Stick Duo,” **MEMORY STICK DUO**, “Memory Stick PRO Duo,” **MEMORY STICK PRO DUO**, “Memory Stick PRO-HG Duo,” **MEMORY STICK PRO-HG DUO**, “Memory Stick Micro,” “MagicGate,” and **MAGICGATE** are trademarks of Sony Corporation.
- “PhotoTV HD” is a trademark of Sony Corporation.
- “Info LITHIUM” is a trademark of Sony Corporation.
- Microsoft, Windows, DirectX and Windows Vista are either registered trademarks or trademarks of Microsoft Corporation in the United States and/or other countries.
- Macintosh, Mac OS, iMac, iBook, PowerBook, Power Mac and eMac are trademarks or registered trademarks of Apple Inc.
- Intel, MMX, and Pentium are trademarks or registered trademarks of Intel Corporation.
- Adobe and Reader are either registered trademarks or trademarks of Adobe Systems Incorporated in the United States and/or other countries.
- In addition, system and product names used in this manual are, in general, trademarks or registered trademarks of their respective developers or manufacturers. However, the TM or ® marks are not used in all cases in this manual.

Additional information on this product and answers to frequently asked questions can be found at our Customer Support Website.

<http://www.sony.net/>



Printed on 70% or more recycled paper using VOC (Volatile Organic Compound)-free vegetable oil based ink.

Printed in Japan



3288701110